



## DCO ENVIRONMENTAL COMMITMENTS

*PINS project reference: WS010005*

**PINS document reference: 6.5**

**Report Reference: AU/KCW/LZH/1724/01/DECD  
July 2021**



Baddesley Colliery Offices, Main Road, Baxterley, Atherstone,  
Warwickshire, CV9 2LE.

Telephone : 01827 717891, Fax : 01827 718507

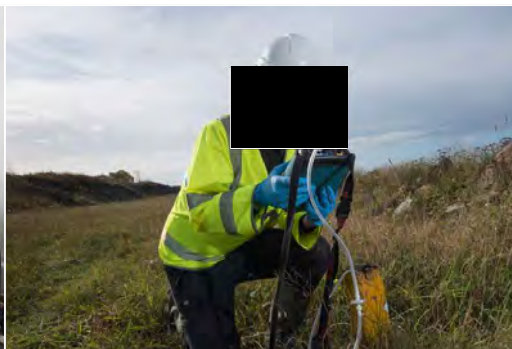

## CONTENTS

1.	<b>Introduction</b>	<b>1</b>
----	---------------------	----------

## TABLES

Table DEC 1 Mitigation measures identified in the Environmental Statement for the proposed western extension to ENRMF

## APPENDICES

Appendix DEC A	Archaeological Mitigation Strategy
Appendix DEC B	Boundary design principles for the proposed western extension Figure DEC B1 Boundaries of the western extension (drawing reference AU/KCW/07-21/22690) Table DEC B1 Boundary standoff design parameters
Appendix DEC C	Relevant parameters for Works No 1, No 2 and No 3 Figure DEC C1 Works areas (drawing reference AU/KCW/07-21/22691)
Appendix DEC D	Phasing sequence Table DEC D1 Anticipated phasing sequence for the continued operation of East Northants Resource Management Facility Figure DEC D1 Illustrative phase boundaries for the existing ENRMF and the western extension (drawing reference AU/KCW/07-21/22692)
Appendix DEC E	Ecological Management, Monitoring and Aftercare Plan
Appendix DEC F	Surface Water Management Plan
Appendix DEC G	Tree Management Scheme Annex DEC G1 Tree Protection Plan
Appendix DEC H	Dust Management Scheme

	Table DEC H1 Dust control measures
Appendix DEC I	Soil Handling and Management Scheme Annex DEC I1 MAFF good practice guide for handling soil. Sheets 1-4 Annex DEC I2 Bird Hazard Management Scheme
Appendix DEC J	Stockpile Management Scheme Figure DEC J1 Temporary stockpile locations (drawing reference AU/KCW/07-21/22693)
Appendix DEC K	Traffic Management Plan Figure DEC K1 Traffic routing plan (drawing reference AU/KCW/07-21/22694)
Appendix DEC L	Noise and Vibration Management Plan

---

This report has been prepared by MJCA with all reasonable skill, care and diligence, and taking account of the Services and the Terms agreed between MJCA and the Client. This report is confidential to the client and MJCA accepts no responsibility whatsoever to third parties to whom this report, or any part thereof, is made known, unless formally agreed by MJCA beforehand. Any such party relies upon the report at their own risk.

## 1. Introduction

- 1.1 Augean South Ltd (Augean) operates the integrated East Northants Resource Management Facility (ENRMF) in Northamptonshire. The ENRMF site has a long history of mineral and waste development and is an established waste treatment and recovery facility together with a hazardous waste and low level radioactive waste (LLW) landfill site. The treatment and recovery facility provides a range of specialist waste management processes for the recovery and disposal of primarily industrial wastes including hazardous and non-hazardous waste. The residues from the treatment processes that are not suitable for recovery are deposited in the adjacent hazardous waste landfill site or the nearby Augean Thornhaugh non-hazardous waste landfill site.
- 1.2 The facilities at ENRMF are an acknowledged part of the nationally significant infrastructure for the management of hazardous waste and LLW and as such serve more than just a local need.

### Planning Consent

- 1.3 The ENRMF was granted a development consent through the East Northamptonshire Resource Management Facility Order 2013 SI 2013 No. 1752) (the 2013 DCO) in July 2013. Work No.1 of the Authorised Project is defined in Schedule 1 of the 2013 DCO as a hazardous waste landfill facility for the disposal of hazardous waste and low level radioactive waste at a direct input rate of up to 150,000 tonnes per annum (tpa)of. Work No. 2 of the Authorised Project is defined in Schedule 1 to the 2013 DCO and includes a soil treatment facility with a consented capacity of 150,000 tpa of contaminated materials comprising predominantly hazardous wastes. The 2013 DCO requires the completion and restoration of the site by 31 December 2026. The East Northamptonshire Resource Management Facility (Amendment) Order 2018 SI 2018 No. 742 was granted on 20 June 2018. The amendment order increased the consented capacity of the soil treatment facility (now known as the waste treatment and recovery facility) to

200,000tpa. The 2013 Order as amended in 2018 will hereafter be referred to as the Original Order.

### **Environmental Permits**

- 1.4** The current operations at ENRMF are the subject of Environmental Permits issued and regulated by the Environment Agency. ENRMF is the subject of three Environmental Permits (EP). There is an EP for the hazardous waste landfill operations, an EP for the waste treatment and recovery facility and an EP for the LLW disposal activities. The proposed extension to the Existing Waste Treatment and Recovery Facility and the Proposed Western Extension will continue to be the subject of Environmental Permits. The extensive protective measures which form an integral part of the operation of the activities authorised by the EPs are designed to provide protection to people and the environment. Accordingly the activities at the site with the greatest potential for impacts on health and the environment are protected through the pollution control regime and regulated by the Environment Agency rather than being controlled through the Original Order. This will remain the case for the Proposed Development.

### **Purpose of this document**

- 1.5** This document is included as part of the DCO application for the Proposed Development. The proposals comprise an increase in the throughput of the Existing Waste Treatment and Recovery Facility and an extension in the area of the facility, the Proposed Western Extension, which is a western extension to the existing Landfill Facility and an extension in the duration of the operations of both existing facilities to 2046. Further details on the Proposed Development are provided in the accompanying Environmental Statement (Sections 5 to 9).
- 1.6** The purpose of this document is to collate and clearly identify the environmental commitments that need to be secured as mitigation through the

DCO as well as the enhancements that Augean has committed to deliver and those environmental and operational controls that will continue to be implemented and regulated through the EPs for the site. The mitigation measures for the proposals relevant to each of the technical aspects that have been assessed in the Environmental Impact Assessment are summarised in Table DEC 1. The enhancements included in Table DEC 1 comprise the commitments that Augean currently make and will continue to make with respect to the community such as provision of monitoring data on the Augean website. However, these enhancements are not taken into account when assessing the planning balance and should not be taken into account by the Secretary of State in the determination of the application. As can be seen from Table DEC 1 the vast majority of the environmental controls that are in place and will continue to be implemented for the Proposed Development to minimise potential impacts on human health and the environment are embedded in the Environmental Permits including the engineered containment design of the site, the controls on the waste that can be accepted at the site, the emission controls and thresholds that are implemented to protect human health and the environment and extensive monitoring to confirm compliance with the emission criteria that are set in the EPs.

- 1.7** The EPs include a requirement that the site operations must be managed through a management system that identifies and minimises risks of pollution, including those arising from operations, maintenance, accidents, incidents, non-conformances and any matters drawn to the operator as a result of complaints. It also specifies that the site must be operated using sufficient competent persons and resources. The operations at ENRMF are subject to the Augean externally certified ISO14000 standard Environmental Management System (EMS) under which all the operational procedures are developed, implemented, audited and regularly reviewed and improved together with procedures for the regular assessment of staff qualifications, experience and training.

- 1.8** A number of mitigation measures and schemes are identified in Table DEC 1 that are not controlled through the pollution control regime. This document incorporates all the schemes for the mitigation and enhancement which are not controlled through the EPs and are therefore necessary to secure the required mitigation. Compliance with the schemes is secured through the Requirements in Schedule 2 of the draft Order. These schemes will be incorporated into the Augean EMS.

Table DEC 1

## Mitigation measures identified in the Environmental Statement for the proposed western extension to ENRMF

Environmental Statement Section	Mitigation measures	Method of securing the mitigation
<p>Waste treatment and landfill operations</p> <p>Flare for the combustion of landfill gas.</p>	<p>The embedded mitigation measures comprise the construction, operation, management and monitoring of the treatment facility and the landfill site in accordance with specifications and procedures controlled through the Environmental Permits. The mitigation measures include regular monitoring of emissions from the site in accordance with the Environmental Permit and submission of the results to the Environment Agency.</p> <p>The containment design detail including the depth to the base of the landfill site and the stability of the slopes will be agreed with the Environment Agency for each phase prior to construction.</p> <p>The landfill operations are carried out in a sequence of phases to limit the operational area at any one time.</p>	<p>The site design and operational controls are regulated through the Environmental Permits by the Environment Agency under the pollution control regime.</p> <p>Construction Quality Assurance Plans are approved and controlled under the Environmental Permit.</p> <p>Phasing sequence (Appendix DEC D). Details of phasing must accord with the phasing sequence table and must be</p>



Environmental Statement Section	Mitigation measures	Method of securing the mitigation
	The landfill restored landform is designed to maximise surface water runoff as well as to integrate into the landscape.	submitted to the relevant planning authority for approval pursuant to Requirement 4 of the draft Order.  The restored landform profile plan is a certified plan under Article 18(1)(c) of the draft Order. Compliance is secured under Requirement 3(d) of the draft Order.
Population including impacts on human health	The embedded mitigation measures comprise the construction, operation, management and monitoring of the treatment facility and the landfill site in accordance with specifications and procedures controlled through the Environmental Permits. The mitigation measures include procedures for waste assessment, waste acceptance, waste receipt, treatment and storage and waste deposit as well as regular monitoring of emissions from the site in accordance with the Environmental Permit and submission of the results to the Environment Agency.	The site design and operational controls are regulated through the Environmental Permits by the Environment Agency under the pollution control regime.
Ecology and biodiversity	Identification and protection of a Root Protection Area.	Boundary design principles for the proposed western extension (Appendix DEC B). Compliance is secured by Requirement 3 of the draft Order.

Environmental Statement Section	Mitigation measures	Method of securing the mitigation
		<p>Tree Management Scheme (Appendix DEC G). The DEC is a certified document under Article 18(1)(e) of the draft Order. Compliance is secured through Requirement 4 of the draft Order.</p> <p>Ecological Management, Monitoring and Aftercare Plan (Appendix DEC E). Compliance is secured by Requirement 4 of the draft Order.</p>
	<p>Identification and protection of woodland margin habitat.</p> <p>The site margins will be enhanced through management to create increased and improved habitat for invertebrates and herpetofauna and improve foraging for badgers. The enhancements will benefit amphibians, adders, bats and badgers.</p>	<p>Boundary design principles for the proposed western extension (Appendix DEC B). Compliance is secured by Requirement 3 of the draft Order.</p> <p>Ecological Management, Monitoring and Aftercare Plan (Appendix DEC E). Compliance is secured by Requirement 4 of the draft Order.</p>
	<p>Erection of protective fences to prevent amphibians (including GCN), badgers and deer from entering the operational area to prevent death or injury.</p>	
	<p>Protection and enhancement of identified hedgerows which will remain in place throughout the development.</p>	<p>Ecological Management, Monitoring and Aftercare Plan (Appendix DEC E). Compliance is secured by Requirement 4 of the draft Order.</p>

Environmental Statement Section	Mitigation measures	Method of securing the mitigation
	Searching, trapping and supervision as necessary prior to and during clearance and removal of the vegetation prior to the commencement of each phase of the development	Ecological Management, Monitoring and Aftercare Plan (Appendix DEC E). Compliance is secured by Requirement 4 of the draft Order.
	Management and control of invasive plant species	<p>The current invasive species on site are managed in accordance with legal obligations and relevant guidance. Compliance is secured through Requirement 4 of the draft DCO.</p> <p>Ecological Management, Monitoring and Aftercare Plan (Appendix DEC E). Compliance is secured by Requirement 4 of the draft Order.</p>
	The creation of the six east to west hedgerows as part of the pre-commencement works and progressive restoration of the site will provide additional movement and foraging areas for adders.	<p>Ecological Management, Monitoring and Aftercare Plan (Appendix DEC E). Compliance is secured by Requirement 4 of the draft Order.</p> <p>The Restoration Concept Scheme is a certified plan under Article 18(1)(d) of the draft Order. Compliance is secured by Requirement 4 of the draft Order.</p>
	Dust control measures	Dust Management Scheme (Appendix DEC H). Compliance is secured by Requirement 6(2) of the draft Order

Environmental Statement Section	Mitigation measures	Method of securing the mitigation
	Water control measures	<p>Emission limits for dust deposition are included in the Environmental Permit.</p> <p>During the operation of Proposed Development site water management is controlled under the Environmental Permit.</p> <p>Once the facility ceases to operate and the site is restored water will be managed in accordance with the Surface Water Management Plan (Appendix DEC F) . Compliance is secured by Requirement 3(e) of the draft Order</p>
	<p>The site is restored in accordance with the Restoration Concept Scheme</p> <p>Implementation of a phasing, landscaping and restoration plan with regular reviews on progress</p>	<p>The Restoration Concept Scheme is a certified plan under Article 18(1)(d) of the draft Order. Compliance is secured by Requirement 4 of the draft Order.</p> <p>Compliance is secured by Requirement 4 of the draft Order.</p>
Landscape and visual effects	<p>Advance planting of hedgerow with trees along the eastern boundary of the southern section of the western extension area to provide visual screening</p> <p>The landfill operations and restoration are carried out in a sequence of phases to limit the operational area at any one time.</p>	<p>Ecological Management, Monitoring and Aftercare Plan (Appendix DEC E). Compliance is secured by Requirement 4 of the draft Order.</p> <p>Phasing sequence (Appendix DEC D). Compliance is secured by Requirement 4 of the draft Order.</p>

Environmental Statement Section	Mitigation measures	Method of securing the mitigation
	<p>Stockpiles shall be managed in accordance with the stockpile management plan.</p>	<p>Stockpile Management Scheme (Appendix DEC J). Compliance is secured by Requirement 6(1) of the draft Order.</p>
	<p>The site is restored in accordance with the Restoration Concept Scheme</p>	<p>The Restoration Concept Scheme is a certified plan under Article 18(1)(d) of the draft Order. Compliance is secured by Requirement 4 of the draft Order.</p>
	<p>Implementation of a phasing landscaping and restoration plan with regular reviews on progress</p>	<p>Compliance is secured by Requirement 4 of the draft Order.</p>
<p>Soil resources and agricultural land classification</p>	<p>All soil handling, movement and storage will be undertaken in accordance with schemes based on the MAFF Good Practice Guide for Handling Soils.</p> <p>BMV soils in the north of the western extension will be husbanded for use in the development of calcareous grassland in the restored site.</p> <p>A bird hazard management scheme to be implemented during soil stripping.</p> <p>Stockpiles shall be managed in accordance with the stockpile management plan.</p>	<p>Soil Handling and Management Scheme (Appendix DEC I). Compliance is secured by Requirement 6(2) of the draft Order.</p> <p>The Restoration Concept Scheme is a certified plan under Article 18(1)(d) of the draft Order. Compliance is secured by Requirement 4 of the draft Order.</p> <p>Bird Hazard Management Scheme. Annex DEC I1 to the Soil Handling and Management Scheme (Appendix DEC I). Compliance is secured by Requirement 6(2) of the draft Order.</p>

Environmental Statement Section	Mitigation measures	Method of securing the mitigation
		Stockpile Management Scheme (Appendix DEC J). Compliance is secured by Requirement 6(1) of the draft Order.
Archaeology and cultural heritage	<p>Soil stripping under the direction of an archaeologist followed by archaeological excavation of two defined areas</p> <p>Watching brief during any excavation or soil stripping in the service corridor for the existing electricity cable route and the service corridor for the water pipes prior to placement of the diverted electricity cable.</p>	Archaeological Mitigation Strategy (Appendix DEC A). Compliance is secured by Requirement 9 of the draft Order.
Water resources	<p>The embedded mitigation measures comprise the construction, operation, management and monitoring of the treatment facility and the landfill site in accordance with specifications and procedures controlled through the Environmental Permits. The mitigation measures include regular monitoring of emissions from the site in accordance with the Environmental Permit and submission of the results to the Environment Agency.</p> <p>The design and implementation of the surface water management plan.</p>	<p>The site design and operational controls are regulated through the Environmental Permits by the Environment Agency under the pollution control regime.</p> <p>Surface Water Management Plan (Appendix DEC F). Compliance is secured by Requirement 3(1)(e) of the draft Order.</p>
Flood risk assessment	Implementation of the surface water management plan for the restored site.	Surface Water Management Plan (Appendix DEC F). Compliance is secured by Requirement 3(1)(e) of the draft Order.

Environmental Statement Section	Mitigation measures	Method of securing the mitigation
Transport and traffic	Traffic routing agreement.	Traffic Management Plan (Appendix DEC K). Compliance is secured by Requirement 11 of the draft Order.
	Annual contribution for highway maintenance to the Highways Authority for the maintenance of the roads.	Section 106 Agreement
Noise and vibration	Standard noise and vibration mitigation measures	Noise and Vibration Management Plan (Appendix DEC L). Compliance is secured by Requirement 5 of the draft Order.
	Noise compliance monitoring	
Air quality	Emissions to the atmosphere are measured through monitoring programmes that are agreed with the Environment Agency and regulated through the Environmental Permits.	The operational controls are contained within the Environmental Permits.
Amenity	Measures will be continued to be implemented to minimise the impacts of dust and mud on the road.	Traffic Management Plan (Appendix DEC K). Compliance is secured by Requirement 11 of the draft Order.
	Dust Control Measures	Wheel cleaning. Compliance is secured by Requirement 13 of the draft Order.  Dust Management Scheme (Appendix DEC H). Compliance is secured by Requirement 6(2) of the draft Order.

Environmental Statement Section	Mitigation measures	Method of securing the mitigation
		Emission limits for dust deposition are included in the Environmental Permit.
Socio-economic impacts	<p>High standards of engineering and operational practice will continue to be applied at the site so that the activities do not result in significant environmental impact in the short or long term.</p> <p>The site will be restored to blend with the surroundings and enhance the ecology and biodiversity of the site resulting in biodiversity improvements and a long term benefit in respect of green infrastructure well beyond the operational life of the site.</p>	<p>The site design and operational controls are regulated through the Environmental Permits by the Environment Agency under the pollution control regime.</p> <p>Restoration Concept Scheme. Compliance is secured by Requirement 4 of the draft Order.</p>
	<p>To continue to provide contributions to a community fund based on the quantity of LLW inputs to the landfill.</p> <p>To continue to make a contribution of funding to the Local Highway Authority for the maintenance of Stamford Road.</p>	<p>Section 106 Agreement, Schedule 1(1) and Schedule 2(1)</p>



Environmental Statement Section	Mitigation measures	Method of securing the mitigation
	<p><b>Commitments</b></p> <p>To continue to make available community funding from the Landfill Tax Credits as permitted by Government legislation.</p> <p>To continue to take an active part in communications through a Local Liaison Group for the site.</p> <p>To continue to use and give preference to of a range of local services.</p> <p>To continue to take part in and support educational activities and promotion of understanding of waste management through the open door policy, regular open days, periodic community newsletters, the reception of visits from educational establishments and presentations to stakeholders.</p>	<p>N/A. Enhancement.</p> <p>Augean are committed to continuing to provide the enhancements identified to support the local community in the vicinity of the site.</p>
<p>Climate change and natural disasters</p>	<p>Implementation of the Surface Water Management Plan</p> <p>Creation of new blue and green infrastructure through habitat creation</p>	<p>Surface Water Management Plan (Appendix DEC F). Compliance is secured by Requirement 3(1)(e) of the draft Order.</p>

Environmental Statement Section	Mitigation measures	Method of securing the mitigation
Health and wellbeing	<p>The site will be restored to blend with the surroundings and enhance the ecology and biodiversity of the site resulting in biodiversity improvements and a long term benefit in respect of green infrastructure well beyond the operational life of the site.</p> <p>Public access to the site will be available and encouraged by the provision of footpaths and a car park for visitors.</p>	Restoration Concept Scheme. Compliance is secured by Requirement 4 of the draft Order.
	To continue to provide contributions to a community fund based on the quantity of LLW inputs to the landfill.	Section 106 Agreement

Environmental Statement Section	Mitigation measures	Method of securing the mitigation
	<p><b>Commitments</b></p> <p>Monitoring data will continue to be presented for review by the public on the Augean web site. The regular monitoring provides confirmation that the mitigation measures are effective.</p> <p>To continue to take an active part in communications through a Local Liaison Group for the site.</p> <p>To continue to take part in and support educational activities and promotion of understanding of waste management through the open door policy, regular open days, periodic community newsletters, the reception of visits from educational establishments and presentations to stakeholders.</p> <p>To continue to make available community funding from the Landfill Tax Credits as permitted by Government legislation.</p> <p>To continue to use and give preference to of a range of local services.</p>	<p>N/A. Enhancement.</p> <p>Augean are committed to continuing to provide the enhancements identified to support the local community in the vicinity of the site.</p>

**APPENDIX DEC A**  
**ARCHAEOLOGICAL MITIGATION STRATEGY**



consultancy | project management | expert witness

**PINS Project Reference: WS010005**

**Planning Act 2008**

**The Infrastructure Planning (Applications:  
Prescribed Forms and Procedures) Regulations  
2009  
Regulation 5(2)(a)**

**E:mail [andyjosephs@hotmail.com](mailto:andyjosephs@hotmail.com) • Telephone 07990 571908**

**Waltham House, 11 Unity Road, Stowmarket, IP14 1AS**

Andrew Josephs Ltd. Registered Office, Fulford House, Newbold Terrace, Leamington Spa, England, CV32 4EA.

Registration no. 4547366

## CONTENTS

<b>1</b>	<b>Introduction</b>	<b>3</b>
<b>2</b>	<b>Archaeological Baseline</b>	<b>4</b>
<b>3.</b>	<b>Archaeological Mitigation</b>	<b>8</b>

### **Appendix A**

Approval of this Archaeological Mitigation Strategy by the  
Northamptonshire County Archaeologist

**Figures** after page 18

# 1. Introduction

---

## 1.1 SCOPE OF THIS WSI AND PROPOSED WORK

1.1.1 This Archaeological Mitigation Strategy (AMS) has been prepared by Andrew Josephs Associates on behalf of Augean South Ltd (Augean). It details the methodology for undertaking a programme of archaeological works on land that is proposed as an extension to a hazardous waste facility at the East Northants Resource Management Facility (ENRMF), Stamford Road, PE8 6XX.

1.1.2 The western extension area is centred on National Grid Reference (NGR) TL 00308 99890 and extends to 29.16 hectares. **Figure 1** shows the location of the proposed development and the extension area which is currently under agricultural usage.

1.1.3 As part of the planning application and EIA, a desk-based assessment, geophysical survey and trial-trenching was undertaken.

1.1.4 The purpose of this AMS is to define the scope of work required to mitigate the effects of the development on archaeology. It has been approved by the Northamptonshire County Archaeological Service<sup>1</sup> as an appropriate mitigation strategy to be implemented should permission be granted (**Appendix A**). An addendum to this AMS would be produced after the appointment of a contractor that would include details specific to that contractor such as staffing, procedure, health and safety and insurance, as well as stating that they will follow the scope of work set out in this document.

## 1.2 STANDARDS

1.2.1 The appointed contractor will be a Chartered Institute for Archaeologists' Registered Organisation or of equivalent standing.

---

<sup>1</sup> from 1<sup>st</sup> April 2021 the responsible archaeological officer will be based at North Northants Council

## 2. Archaeological Baseline

---

### 2.1 DESK-BASED RESEARCH

2.1.1 A desk-based assessment was carried out. The results are documented in the Heritage Statement that accompanies the planning application<sup>2</sup>. A brief summary is presented below.

#### Archaeology within the western extension area

2.1.2 Three entries are recorded within the western extension area. They comprise an area on the enclosure award map that was probably lawn, a fieldname and a crop mark of a field boundary that appears on the 1950s Ordnance Survey mapping.

2.1.3 No archaeological investigations are known to have taken place within the western extension area prior to the current project, although it is considered likely that the western extension area was fieldwalked by David Hall during his extensive fieldwalking programme of the local landscape between 1960 and 1999.

2.1.4 Aerial photographs of the western extension area were examined as part of the National Mapping Programme, and the field boundary that used to cross the centre of the western extension area was identified.

#### Archaeological investigations in the vicinity

2.1.5 The vicinity of the western extension area has been extensively examined, in particular by David Hall. Numerous archaeological sites have been located, notably of Roman date, and including possible settlements, buildings and ironworking located by fieldwalking. The National Aerial Photographic Mapping Programme has covered the area.

2.1.6 A large number of landscape features were identified from the Rockingham Forest Project. Supported by the Heritage Lottery Fund and English Heritage its aim was to track the evolution of the Forest from the 10th to 20th centuries. This followed work by David Hall in locating earthwork enclosure banks and ditches.

2.1.7 An archaeological watching brief was undertaken during soil removal in advance of development of the current ENRMF in 2008. No archaeological deposits or artefacts were identified.

---

<sup>2</sup> Josephs, A. 2021. NID Project Reference: WS010005. Heritage Statement. AJA.



2.1.8 An excavation is recorded in Collyweston Great Wood, 900m north-north-east of the western extension area. This took place in 1953-4 and identified a Romano-British temple of several periods of construction including hexagonal and octagonal stone buildings, and associated finds.

2.1.9 In September 2016, an archaeological evaluation was undertaken by Cotswold Archaeology at Collyweston Quarry, 1km west of the western extension area. The evaluation comprised the excavation of eleven trial trenches. A geophysical survey of the site had indicated that it had a low potential for archaeological remains, although a rectilinear anomaly, suggestive of a possible enclosure but interpreted as being of natural origin, was identified. The natural origin of the anomaly, which was probably formed by glacial and periglacial processes, was confirmed and no archaeological remains or artefactual material were encountered elsewhere within the site.

### **Archaeological background**

2.1.10 Few parts of England have been examined in as much detail as this part of Northamptonshire. The combined efforts of David Hall and the former County Archaeologist, Glen Foard, ensured that programmes of desk-based research and field-based examination mapped large numbers of sites and possible sites.

2.1.11 Prehistoric sites are rare. A possible cooking site identified during fieldwalking 340m north of the western extension area was marked by burnt and cracked pebbles. Two possible Bronze Age ring ditches were identified approximately 1km north-west of the western extension area. In this same area there is evidence for an Iron Age smelting site. A further possible prehistoric barrow was identified in Westhay Wood, to the south of the western extension area, comprising a low mound about 15m in diameter.

2.1.12 Despite fieldwalking and aerial photographic assessment, and a large number of Roman sites in the landscape, there are no known Roman sites close to the western extension area. The nearest is 500m distant and comprised a significant find scatter of Roman date including building stone and pottery, located by David Hall. About 900m to the north-east of the western extension area there is the Romano-British temple complex, referred to above (para 2.1.8) and a further probable settlement and ironworking site lies 1200m south-east of the western extension area. A similar Roman settlement, including evidence for a building from aerial photographs and ironworking, lies to the east of Westhay Lodge. A Romano-British iron smelting furnace (was found in a 1977 watching brief 1.25km north west of the western extension area and a possible section of a Roman road is also recorded. The latter was identified by a 1982 aerial survey, 1.2km west of the western extension area. In addition to the iron slag from defined sites,

further undated surface finds might reflect the more extensive nature of metal working in the Roman period.

2.1.13 The medieval and post-medieval periods have been intensively examined, both in the field by David Hall who mapped earthwork enclosure banks and ditches, and more recently by the Rockingham Forest Project. The landscape of these periods has been re-created with some success. Given that this is an area of historic woodland it is of no surprise that woodland activities are present within the study area, and in particular the production of charcoal. Five locations scattered across the study area produced evidence suggesting charcoal production of which only one is dated, in that case to the post- medieval period.

## **2.2 GEOPHYSICAL SURVEY**

2.2.1 Geophysical survey was carried out by Tigergeo in November 2019 and May 2020<sup>3</sup>.

2.2.2 There was very little identified that could be described, with certainty, as of archaeological interest, most of the suitable anomalies being non-connected linear examples with weak magnetic enhancement and no coherent layout. Some were considered to be ditch fills, others drains or former paths, and some contrast so weakly defined from their surroundings as to be only tentatively identified. The southern part of the western extension area is dominated by services, pipelines and under-drainage.

2.2.3 The main features identified were ditch fills that define the western part of a small rectilinear enclosure. They lacked internal features but the strength of magnetic enhancement associated with the fills, relative to other ditch fills on the site, might suggest the presence of materials commonly associated with intensive use. These can include cultural debris and heated soils.

## **2.3 ARCHAEOLOGICAL TRIAL TRENCHING**

2.3.1 The Museum of London's Northampton Office carried out trial-trenching across the western extension area in October and November 2020.

2.3.2 The trenching targeted geophysical anomalies to check their origin and blank areas to act as a control. In total the evaluation comprised the excavation of fifty-one 50m x 1.8m trial trenches.

2.3.3 The results of the evaluation<sup>4</sup> identified low levels of activity from the Roman period onwards. Where present, archaeological preservation levels

---

<sup>3</sup> Tigergeo. 2020. Land near King's Cliffe, Northamptonshire. Geophysical Survey Report.

were consistently high and most of the remains encountered did not appear to have been significantly affected by modern activities, such as ploughing. Features of interest were primarily concentrated within the northern half of the northern field and the north-eastern extent of the southern field.

2.3.4 A sparse artefactual assemblage was recovered during the investigation, which has left the majority of the encountered archaeological features undated. The paucity of datable material has hindered understanding of the chronological progression of the site's formation and development. However, it is probable that the archaeological remains recorded represent a focus on the economy of the landscape, predominantly concerning stock management.

2.3.5 Two ditches thought to form part of a large, square enclosure identified by the geophysical survey were excavated in the northern field (Trenches 10 and 11). No internal features associated with the enclosure were identified within the constraints of the evaluation. As such, it is possible that these ditches functioned as boundaries for a field system and perhaps delineated an enclosed area related to farming management. The animal bone assemblage recovered indicates that cattle, sheep or goat are the most probable species of livestock which may have been managed within this system. Neither ditch revealed evidence of prolonged use.

2.3.6 Potential charcoal production was evidenced in one location within the southern half of trench 33. The feature (a pit) was similar to small charcoal production pits identified at several sites in the east of England. As only a single feature associated with this activity was identified during the evaluation, it is probable that this represents a very small-scale of charcoal production, possibly for domestic purposes rather than industrial.

2.3.7 At present, the relationship between this probable enclosure and the further undated archaeological features remains unclear. It is possible that the features concentrated within the northern half of the northern field may be associated with the enclosure ditches, perhaps defining land or route boundaries and providing field drainage

2.3.8 The results of the evaluation corroborated the geophysical survey. It identified only a sparse number of archaeological features given the size of the site and there is limited potential to address the research objectives detailed in the regional research agenda.

---

<sup>4</sup> Collins, C. 2020. Archaeological Evaluation at ENRMF Proposed Extension, Northamptonshire. MOLA report 20/076.

### 3. Archaeological Mitigation

---

#### 3.1 OVERVIEW OF PROPOSED MITIGATION

3.1.1 National Planning Policy Framework 2019 requires developers to record and advance understanding of heritage assets to be lost and make this evidence publicly accessible (paragraph 199). This can include a programme of archaeological work secured by condition/s on planning permission.

3.1.2 In this case, a programme of pre-development archaeological work secured by condition would be appropriate. This would comprise:

- Soil stripping under the direction of an archaeologist followed by archaeological excavation of two defined areas shown on **Figures 2-4**.
- Watching brief during development within existing service corridors that could not be evaluated as part of the EIA (**Figure 2**).
- The deposition of reports with the Historic Environment Record, the deposition of archives with the appropriate public museum or receiving institution (normally Northamptonshire Archaeological Resource Centre) and publication commensurate with the significance of any discoveries made.
- Public outreach appropriate to the significance of the findings.

#### 3.2 ARCHAEOLOGICAL EXCAVATION

##### Methodology

3.2.1 The appointed contractor will secure a NHER event and OASIS numbers before commencing fieldwork.

3.2.2 It is proposed to carry out the work in one or two phases dependent upon the availability of the land from the farmer. This is better for recording the continuity of archaeological features.

3.2.3 Soils will be removed within the excavation area by a 360-machine equipped with a toothless bucket under archaeological direction. All subsequent excavation will be undertaken by hand, although mechanical equipment may be used to remove modern deposits or geological features with the agreement of the Northamptonshire CC Archaeologist. Exposed surfaces will be selectively cleaned in order to aid the identification of any features.

## **Sampling strategies and recording**

### 3.2.4 Sampling strategies would include:

- 50% of intrusive non-structural features (pits, random postholes). Up to 50% (by number) to be then fully excavated following assessment.
- At least 10 % of each linear feature's exposed area, and all terminals & intersections if definition of relationships is unclear. The actual percentage amount will depend on the type of site being investigated, and, for example, lengths of post-medieval field ditch system that have previously been sampled and dated in previous phases would require only limited further excavation to be undertaken, comprising examination of their terminals and intersections.
- 100% of domestic/industrial working features (hearths, ovens), graves and features of high palaeo-environmental potential (excluding ponds and palaeo-channels).

3.2.5 All exposed archaeological deposits will be recorded using a pro forma recording system.

3.2.6 All archaeological contexts will be recorded on context record sheets. A further more-general record of the work comprising a description and discussion of archaeological remains will be maintained as appropriate. Context sheets will be primarily filled in by the archaeologist excavating the feature or deposit. Context sheets will be checked for completeness and accuracy on a regular basis and before the area in which they occur is signed off.

3.2.7 Context information will be entered into a scheme database. Context grouping will be carried out in parallel with fieldwork. If appropriate a Harris Matrix will be compiled for each area of investigation during the course of fieldwork.

3.2.8 A complete drawn record of excavated archaeological features and deposits will be compiled. This will include both plans and sections, drawn to appropriate scales (generally 1:20 or using survey grade GPS for plans, 1:10 for sections), and with reference to a site grid tied to the OS National Grid. The OD height of all principal features and levels will be calculated and plans/sections will be annotated with OD heights. Drawn plans and sections will be on polyester-based drafting film and clearly labelled.

3.2.9 A full photographic record will be maintained using digital cameras. The photographic record will illustrate both the detail and the general context of the principal features, finds excavated, and the site as a whole.

3.2.10 Photographs will be recorded on *pro forma* Record Sheets.

## **Finds**

### *Finds*

3.2.11 All artefacts from excavated contexts will be retained, except those from features or deposits of obviously modern date. In such circumstances, sufficient artefacts will be retained in order to elucidate the date and/or function of the feature or deposit. Material of undoubtedly modern date observed on the spoil heap of each trench would not be noted or retained.

3.2.12 Artefacts will be recovered carefully by hand excavation. An appropriately qualified and experienced archaeological conservator will assist where appropriate in the lifting of fragile finds of significance and/or value.

3.2.13 Artefacts will be collected and bagged by archaeological context. The location of special finds will be recorded in three dimensions. Three-dimensional recording of *in-situ* flint working deposits will be carried out, as appropriate.

3.2.14 Where appropriate to address the research objectives of the archaeological investigation, sieving of deposits will be undertaken to maximise recovery of small artefacts.

3.2.15 Registers of artefact assemblages and special finds will be maintained throughout the course of fieldwork and post excavation works. Records of artefact assemblages will clearly state how they have been recovered, sub-sampled and processed.

3.2.16 Excavated artefacts will be bagged upon recovery or placed in finds trays. They will not be left loose on site. Artefacts will normally be stored in plastic bags which contain two plastic labels. Labels will be clearly marked in indelible ink with site code, context number and date of finding.

3.2.17 Special finds, those of a fragile nature or requiring special conditions will be individually packaged and labelled as appropriate to the artefact. Where appropriate, for example in the case of fragile faunal remains of early prehistoric date, the advice of a suitably qualified conservator will be sought with regard to their lifting, storage and conservation.

3.2.18 All retained artefacts will, as a minimum, be washed, weighed, counted and identified. Any artefacts requiring conservation or specific storage conditions will be dealt with immediately in line with *First Aid for Finds* (Watkinson & Neal 1998). Ironwork from stratified contexts will be X-rayed and stored in a stable environment along with other fragile and delicate material. The X-raying of objects and other conservation needs will be undertaken by an appropriate approved conservation centre. Suitable material, primarily the pottery, worked flint and non-ferrous metalwork, will be scanned to assess the date range of the relevant assemblages.

### *Vertebrate remains*

3.2.19 If faunal remains are recovered, their condition should be considered: it might be appropriate to record the remains in-situ and lift following consultation with a specialist conservator.

### *Treatment of treasure*

3.2.20 Finds falling under the statutory definition of Treasure (as defined by the Treasure Act of 1996 and its revision of 2002) will be reported immediately to the relevant Coroner's Office, the landowner, the Northamptonshire CC Archaeologist and the Portable Antiquities Scheme. A Treasure Receipt will be completed and a report submitted to the Coroner's Office within 14 days of understanding that the find is Treasure. The Treasure Receipt and Report will include the date and circumstances of the discovery, the identity of the finder and (as exactly as possible) the location of the find

### *Human Remains*

3.2.21 If human remains are encountered, the Northamptonshire CC Archaeologist, the Coroner and the client will be informed. Removal of these remains will be carried out in accordance with all appropriate Environmental Health regulations and will only occur after a Ministry of Justice licence has been obtained.

3.2.22 Where practicable, inhumation burials will be fully excavated by hand within 24 hours of exposure. Cremations should be lifted en-bloc and excavated in the laboratory.

3.2.23 The client will put in place arrangements to ensure the security, protection from deterioration, damage and criminal activity, and the respectful treatment of human remains and burial goods.

3.2.24 All excavation and post-excavation analysis of human remains will be in accordance with the standards set out in CIFA Technical Paper 13 *Excavation and post-excavation treatment of cremated and inhumed remains* and in the Historic England reporting guidelines: *Human Bones from Archaeological Sites: Guidelines for Producing Assessment Documents and Analytical Reports*, 2004. Appropriate specialist guidance/site visits will be undertaken by suitably qualified specialists. The final deposition of human remains following analysis will be subject to the requirements of the Ministry of Justice Licence.

### **Environmental sampling**

3.2.25 Environmental sampling appropriate to the aims of the project will be implemented. Samples will be taken from archaeologically significant features and deposits, where appropriate. Advice will be sought as appropriate from the Historic England Regional Science Advisor. The strategy and

methodology for the sampling, recording, processing, assessment, analysis and reporting of deposits with environmental archaeology potential will be in accordance with Historic England *Environmental Archaeology - A guide to theory and practice of methods, from sampling and recovery to post-excavation*, second edition, 2011. Any variation to this guidance will be agreed in advance with the Historic England Science Advisor and the Northamptonshire CC Archaeologist.

3.2.26 Bulk environmental soil samples for charred plant macrofossils, small animal bones and other small artefacts will be taken from appropriate well sealed and dated/datable archaeological contexts. Samples of between 40-60 litres will be taken or 100% of smaller contexts. Samples will not be taken from the intersection of features or across context boundaries.

3.2.27 Bulk environmental soil samples will be processed by water flotation and a preliminary assessment for environmental potential will be carried out on an on-going basis. Results will be fed back during fieldwork, in order to guide the course of action for further sampling.

3.2.28 For deposits where anaerobic preservation is seen or expected, 20 litre bulk samples will be taken for the retrieval of uncharred plant macrofossils and insects.

3.2.29 Details of the environmental samples and assemblages will be input into a project database.

3.2.30 A geoarchaeologist will record any deposits of particular significance and advise on depositional processes.

3.2.31 Appropriate provision will be made for the application of scientific dating techniques such as radiocarbon, dendrochronology, archaeomagnetic dating, OSL and TL dating. The advice of the Historic England Science Advisor will be sought in advance of the application of these techniques.

3.2.32 Where appropriate, the guidance in the following Historic England papers will be followed:

- Watkinson, D and Neal V, *First Aid for Finds* (London: Rescue/UKICAS/HE 2001)
- *Animal Bones and Archaeology: Guidelines for Best Practice* 2014
- *Animal Bones and Archaeology - Recovery to archive*, 2019
- *Human bones from Archaeological Sites: Guidelines for Producing Assessment Documents and Analytical Reports*, 2004
- *The Role of the Human Osteologist in an Archaeological Fieldwork Project*, 2018



- *Dendrochronology: Guidelines on producing and interpreting dendrochronological dates*, 2004
- *Guidelines on the X-radiography of archaeological metalwork*, 2006
- *Archaeometallurgy*, 2015
- *Environmental Archaeology: A guide to theory and practice of methods, from sampling and recovery to post-excavation* second edition, 2011
- *Geoarchaeology: Using earth sciences to understand the archaeological record*, 2015
- *Mineralised Plant and Invertebrate Remains*, 2020
- *Waterlogged Wood: Guidelines on the recording, sampling, conservation and curation of waterlogged wood*, 2010
- *Waterlogged Organic Artefacts*, 2018
- *Archaeomagnetic Dating: Guidelines on producing and interpreting archaeomagnetic dates* 2006
- *Guidelines for the Curation of Waterlogged Macroscopic Plant and Invertebrate Remains*, 2008
- *Luminescence Dating: Guidelines on using luminescence dating in archaeology* 2008

### **3.3 FURTHER MITIGATION**

3.3.1 Should significant archaeology be identified that continues outside the defined excavation area, further mitigation may be required. The decision would be taken in consultation with the Northamptonshire CC Archaeologist and the project's archaeological consultant.

### **3.4 REPORTING**

3.4.1 Following completion of all fieldwork a Post-excavation Assessment Report will be produced. This report will include an Updated Project Design that sets out a programme of post-excavation analysis through to completion of the full report and publication of the findings. The report will include, as appropriate:

- A non-technical summary.
- Details of the scheme and the commissioning body.
- A description of the site, including its geology and topography.
- A description of the methods employed during the investigation.
- A review of the effectiveness of the archaeological strategies and methodologies

- A description and interpretation of the results.
- Plans and sections showing archaeological features and deposits.
- Photographs of significant archaeological features and deposits.
- Specialist reports.
- A list of references.
- Tabulated context and finds data.
- Recommendations and a timetable for further analysis and publication.

3.4.2 An Oasis report will be initiated prior to the start of fieldwork and will be updated following the completion of the project.

3.4.3 The scope of the full report and the format and destination of subsequent publication(s) arising from excavation and post-excavation work on the site will be agreed with the Northamptonshire CC Archaeologist.

### **3.5 SPECIALIST INPUT**

3.5.1 A list of specialists to be employed on the project will be submitted to the Northamptonshire CC Archaeologist.

### **3.6 ARCHIVE PREPARATION AND DEPOSITION**

3.6.1 The archive will comprise written, drawn, photographic, digital, artefactual and environmental material.

3.6.2 Throughout the archaeological programme, the archive will be kept secure, clean and stored in a suitable environment.

3.6.3 The site archive, to include all project records and cultural material produced by the project, will be prepared in accordance with *Guidelines for the preparation of excavation archives for long term storage* (UKIC 1990) and *Standards in the Museum Care of Archaeological Collections* (Museums and Galleries Commission 1992).

3.6.4 The archive will be fully catalogued, indexed, cross-referenced and checked for consistency before deposition.

3.6.5 On completion of the project the archaeological contractor will arrange for the archive to be deposited at the appropriate public museum or receiving body (normally Northamptonshire Archaeological Resource Centre), in accordance with arrangements made at the outset of the project. A museum accession number will be requested before post-excavation work commences.

3.6.6 Relevant guidelines and requirements of the museum receiving the archive will be adhered to. The potential for discard of bulk materials will be included within specialist post excavation assessment reports.

3.6.7 All artefactual material recovered will be held in temporary storage and the permission of the landowner will be sought for the transfer of such archaeological finds to the appropriate depository to facilitate future study and ensure proper preservation of all artefacts. In the unlikely event that artefacts of significant monetary value are discovered, and if they are not subject to Treasure Act legislation, separate ownership arrangements may be negotiated.

### **3.7 HEALTH AND SAFETY**

3.7.1 A risk assessment will be undertaken and approved and will be kept on site in a file which will contain all relevant health and safety documentation. The Health and Safety file will be available to view at any time.

3.7.2 All staff will be subject to a Health and Safety induction by Augean South Ltd before commencing work on site.

### **3.8 MONITORING OF WORKS**

3.8.1 The Northamptonshire CC Archaeologist will be informed of dates and arrangements to allow for adequate monitoring of the works. They will have free access to the site (subject to Health and Safety considerations) and all records to ensure the works are being carried out in accordance with this document and all other relevant standards.

### **3.9 EXTERNAL LINKS, EDUCATION AND OUTREACH**

3.10 Subject to Health and Safety considerations, local primary schools may be invited to visit archaeological excavations. Public events could be organised, especially as part of recognised formats such as the Festival of British Archaeology. When deemed appropriate, public open days will also be advertised and held. Local lectures could be given if the results warrant it.

**Appendix A – Approval of this AMS by the Northamptonshire CC  
Archaeologist**

---

WS010005. Archaeological Mitigation Strategy. March 2021.

**From:** Liz Mordue  
**Sent:** 29 March 2021 08:31  
**To:** Andrew Josephs  
**Subject:** RE: Kings Cliffe landfill Archaeological Mitigation Strategy

Dear Andy

Thank you for the AMS. It is all in order and I am happy with the scope of work proposed.

A method statement from the archaeological contractor would of course be expected to confirm that they will follow the AMS.

It may be worth adding a footnote to the AMS to clarify that from 1<sup>st</sup> April 2021 I will be Archaeological Advisor at North Northants Council, rather than at NCC which will no longer exist.

Regards  
Liz

Liz Mordue  
Archaeological Advisor

**From:** Andrew Josephs  
**Sent:** 22 March 2021 08:55  
**To:** Liz Mordue  
**Subject:** Kings Cliffe landfill Archaeological Mitigation Strategy

Dear Liz

Please find attached an AMS for your comments/approval.

Kind regards

Andy

*andrew josephs associates*  
consultancy | project management | expert witness  
Specialists in Archaeology and Cultural Heritage  
[REDACTED]  
Visit our website at [www.andyjosephs.co.uk](http://www.andyjosephs.co.uk)

Scanned by Avast for viruses

## Figures

---

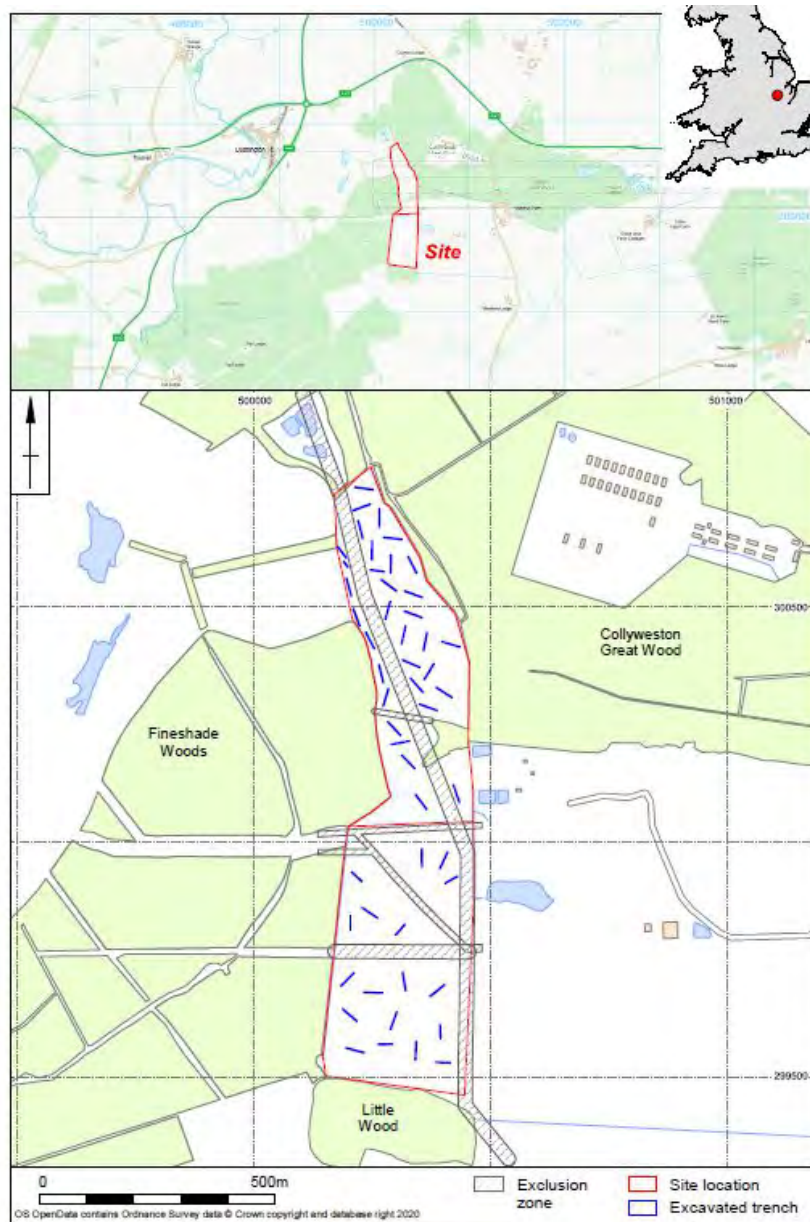

**Figure 1 Site Location and Layout of Trenches**

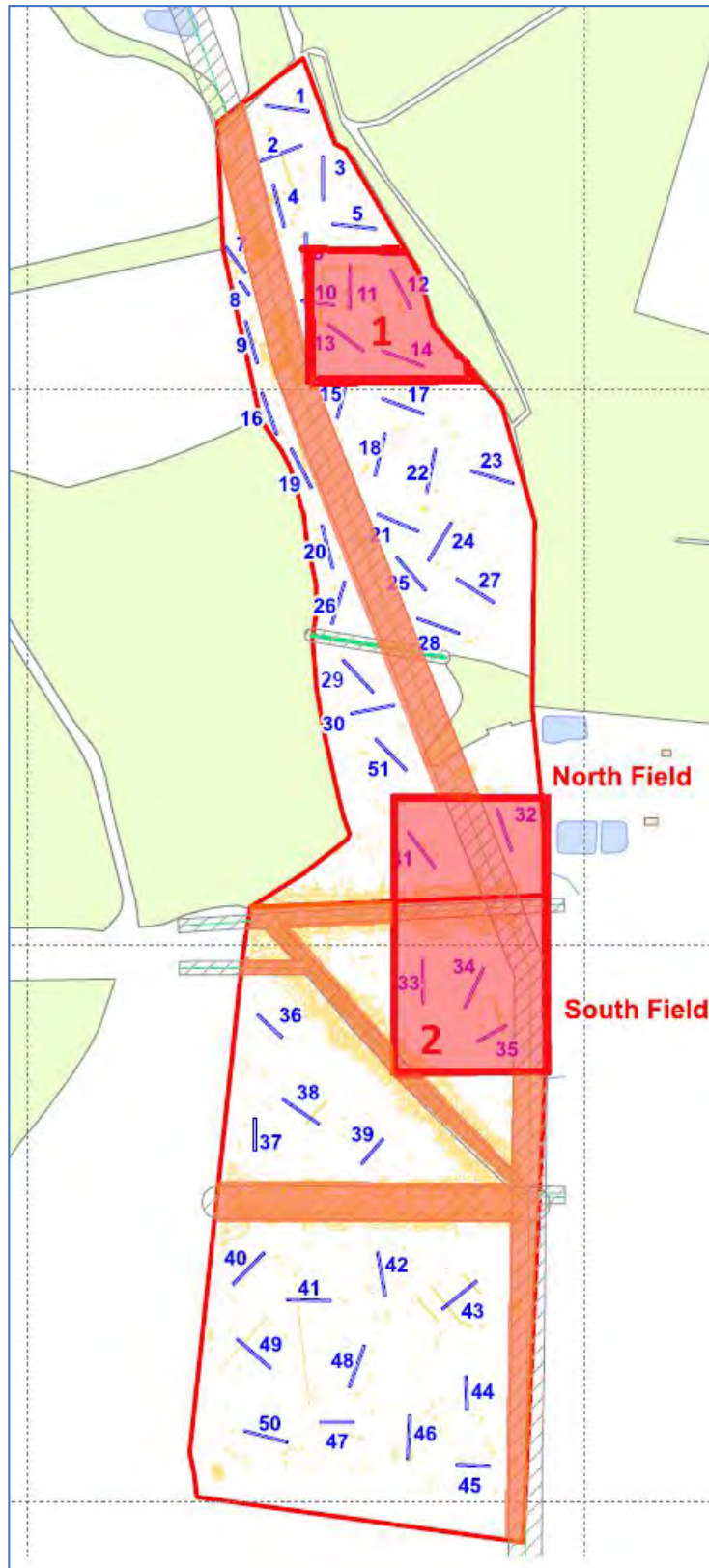

**Figure 2** Set-Piece Excavation Areas (red) and Watching Brief along existing service corridors (orange)



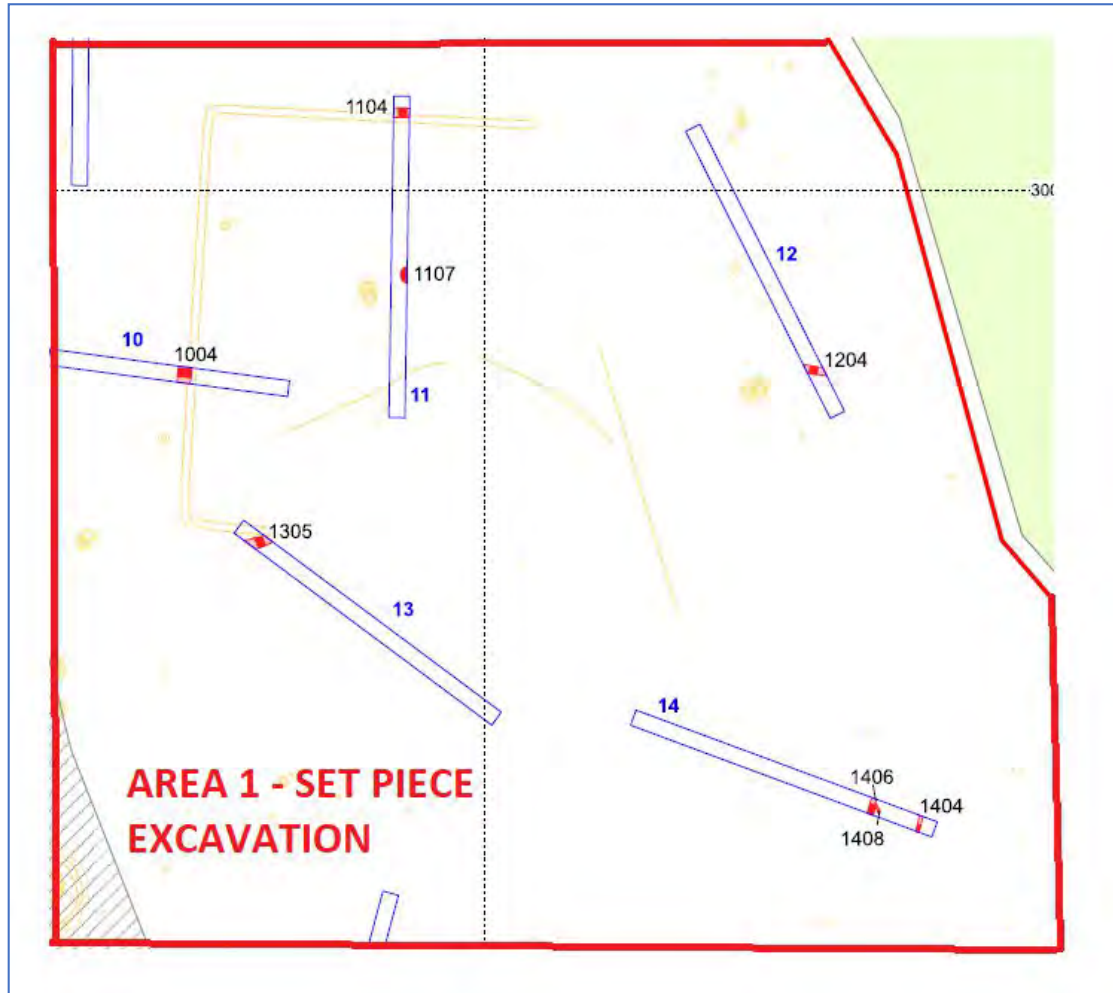
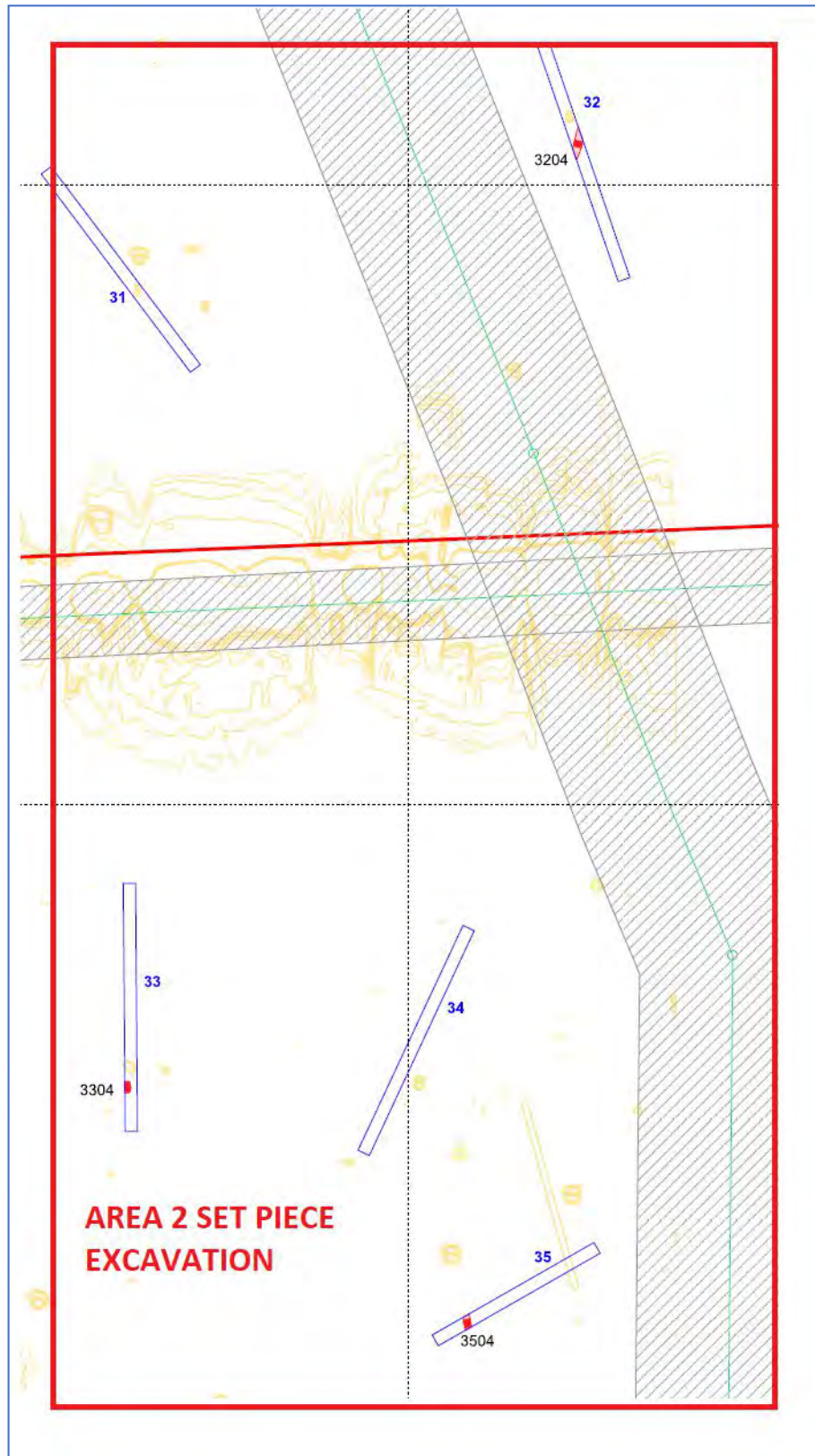

Figure 3 Set-Piece Excavation Area 1 – northern field



**Figure 4 Set-Piece Excavation Area 2 – southern field**



consultancy | project management | expert witness

Specialists in Archaeology and Cultural Heritage

Telephone [REDACTED]

Visit our website at [www.andyjosephs.co.uk](http://www.andyjosephs.co.uk)

**APPENDIX DEC B**







**BOUNDARY DESIGN PRINCIPLES FOR THE PROPOSED WESTERN  
EXTENSION  
FIGURE DEC B1 BOUNDARIES OF THE WESTERN EXTENSION (DRAWING  
REFERENCE AU/KCW/07-21/22690)  
TABLE DEC B1 BOUNDARY STANDOFF DESIGN PARAMETERS**

## Appendix DEC B

### Boundary Design Principles for the proposed western extension

- B1 This document presents the principles for the boundary standoff design for the western extension at ENRMF. The standoffs from the DCO application boundary that will be protected and retained outside the operational area and the protection fencing principles are set out. Each of the boundaries referred to in Table DEC B1 below together with the locations of the approximate phase boundaries are shown on Figure DEC B1 (drawing reference AU/KCW/07-21/22690).
- B2. As explained in Section 5 of the Environmental Statement (PINS document reference 5.2) the derivation of the width of the boundary standoff distance used in the design for each area is based on a combination of:
- Tree root protection area (RPA) distance.
  - Width of the ecological margin to be retained at the edge of the site.
  - Installation of animal exclusion fencing.
  - Standoff from buried services.
  - Working margin inside the animal exclusion fence between the fence and the extraction boundary.
- B3. The exact design including the boundary of each of the phases of the landfill will be determined at the detailed design stage. The design and the construction proposals for each phase will be agreed with the Environment Agency under the Environmental Permit prior to the commencement of construction.

## Key / Notes

-  Boundary of the area the subject of the application for the Development Consent Order
-  Approximate phase boundaries to be constructed in the proposed western extension
-  Approximate phase boundaries for the existing ENRMF
-  Approximate route of water pipelines
-  Approximate route of an overhead electricity cable (to be diverted)
-  Approximate location of a high pressure gas pipeline
-  Boundary identification label used for reference

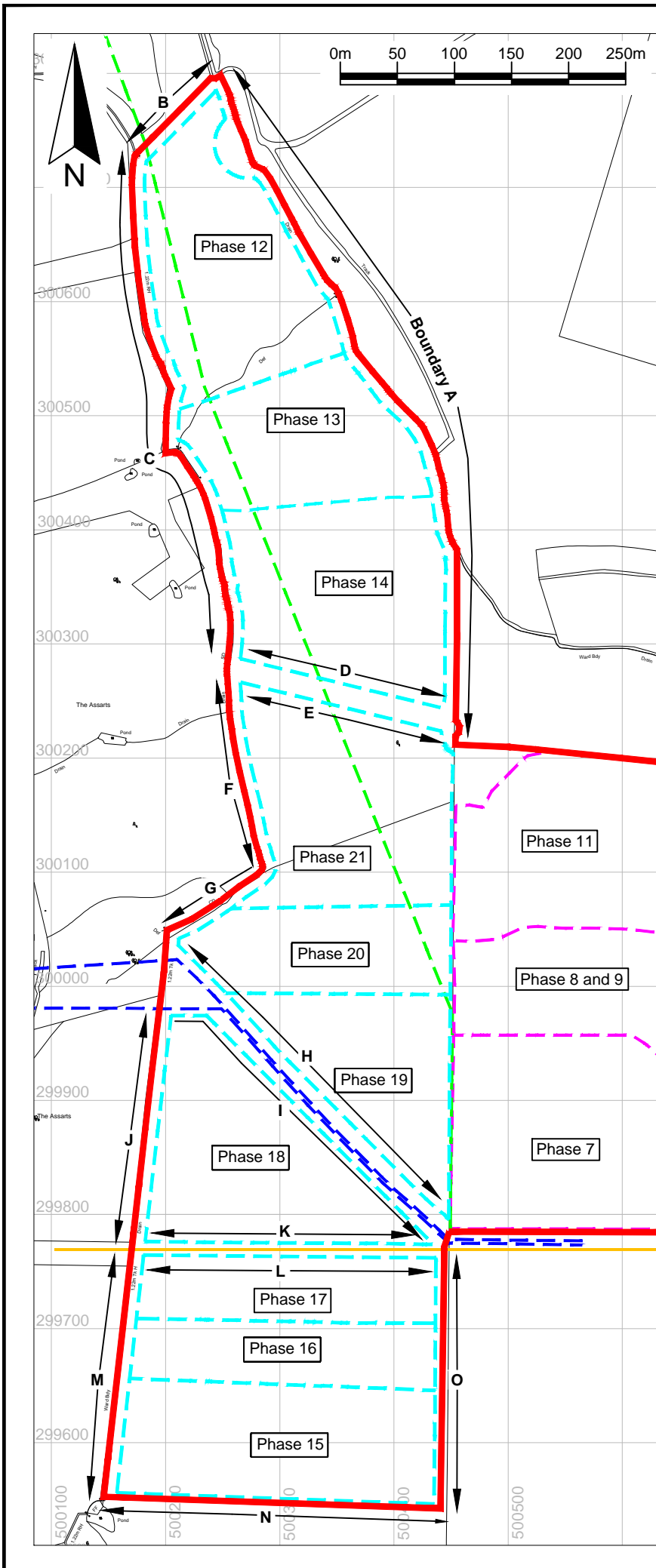

	Final	KR	SPS	LH	26/07/21
Rev	Status	Drn	App	Chk	Date

Site  
EAST NORTANTS RESOURCE MANAGEMENT FACILITY

Client



Title

Boundaries of the proposed western extension

Figure DEC B1

Scale  
1:5,000@A4

Drawing Ref  
AU/KCW/07-21/22690

Reproduced scale mapping by permission of Ordnance Survey on behalf of The Controller of Her Majesty's Stationary Office. © Crown copyright 2017. All rights reserved. Licence number 100017818.

**MJCA** Baddesley Colliery Offices,  
Main Road, Baxterley, Atherstone,  
Warwickshire, CV9 2LE.  
Telephone : 01827 717891  
Technical advisers on environmental issues Fax : 01827 718507

**Table DEC B1**  
**Boundary standoff design parameters**

<b>Boundary (as shown on Figure DEC B1)</b>	<b>Boundary standoff design parameters</b> <i>The excavation limit will be at a minimum 2.5m standoff from the protection fencing in all operational areas to provide access for operations.</i>
Boundary A	<p>Root Protection Area of 7.5m.</p> <p>10m ecological protection standoff from the western bank of the boundary ditch apart from one area in the north east (Phase 12) where the stand off is extended to 30m.</p> <p>Protection fencing will be erected on the 10m stand off line and will comprise amphibian exclusion fencing, deer exclusion fencing and badger exclusion fencing.</p> <p>The restoration soil placement will not extend beyond the line of the fencing.</p>
Boundary B	<p>Root Protection Area of 4.2m.</p> <p>10m ecological protection standoff from the site boundary.</p> <p>Protection fencing will be erected on the 10m stand off line and will comprise amphibian exclusion fencing, deer exclusion fencing and badger exclusion fencing.</p> <p>The restoration soil placement will not extend beyond the line of the fencing.</p>
Boundary C	<p>Root Protection Area of 7.8m.</p> <p>10m ecological protection standoff from the site boundary.</p>

Boundary (as shown on Figure DEC B1)	<b>Boundary standoff design parameters</b> <i>The excavation limit will be at a minimum 2.5m standoff from the protection fencing in all operational areas to provide access for operations.</i>
	<p>Protection fencing will be erected on the 10m stand off line and will comprise amphibian exclusion fencing, deer exclusion fencing and badger exclusion fencing.</p> <p>The restoration soil placement will not extend beyond the line of the fencing.</p>
Boundary D	<p>The boundary will follow the 20m stand off for the doline area.</p> <p>Protection fencing will be erected on the 20m stand off line to the north of the proposed double hedgerow (as shown on the Restoration Concept Scheme, PINS document reference 2.8) and will comprise amphibian exclusion fencing, deer exclusion fencing and badger exclusion fencing.</p> <p>The restoration soil placement will not extend beyond the line of the fencing.</p>
Boundary E	<p>The boundary will follow the 20m stand off for the doline area.</p> <p>Protection fencing will be erected on the 20m stand off line to the south of the proposed double hedgerow and will comprise amphibian exclusion fencing, deer exclusion fencing and badger exclusion fencing.</p> <p>The restoration soil placement will not extend beyond the line of the fencing.</p>
Boundary F	<p>Root Protection Area of 5.4m.</p> <p>10m ecological protection standoff from the eastern bank of the boundary ditch.</p>



Boundary (as shown on Figure DEC B1)	<b>Boundary standoff design parameters</b> <i>The excavation limit will be at a minimum 2.5m standoff from the protection fencing in all operational areas to provide access for operations.</i>
	<p>Protection fencing will be erected on the 10m stand off line and will comprise amphibian exclusion fencing, deer exclusion fencing and badger exclusion fencing.</p> <p>The restoration soil placement will not extend beyond the line of the fencing.</p>
Boundary G	<p>Root Protection Area of 5.4m.</p> <p>10m ecological protection standoff from the eastern bank of the boundary ditch.</p> <p>Protection fencing will be erected on the 10m stand off line and will comprise amphibian exclusion fencing, deer exclusion fencing and badger exclusion fencing.</p> <p>The restoration soil placement will not extend beyond the line of the fencing.</p>
Boundary H	<p>7m standoff from the water pipeline and 3.5m stand off from the diverted electricity cable (which will be located within the 7m standoff for the water pipeline).</p> <p>Protection fencing will be erected on the 7m stand off line and will comprise amphibian exclusion fencing, deer exclusion fencing and badger exclusion fencing.</p> <p>The restoration soils will not extend beyond the pipeline standoff.</p>

Boundary (as shown on Figure DEC B1)	<p align="center"><b>Boundary standoff design parameters</b></p> <p align="center"><i>The excavation limit will be at a minimum 2.5m standoff from the protection fencing in all operational areas to provide access for operations.</i></p>
Boundary I	<p>7m standoff from the water pipeline and 3.5m stand off from the diverted electricity cable (which will be located within the 7m standoff for the water pipeline).</p> <p>Protection fencing will be erected on the 7m stand off line and will comprise deer exclusion fencing.</p> <p>The restoration soils will not extend beyond the pipeline standoff.</p>
Boundary J	<p>Root Protection Area of 6.9m.</p> <p>10m ecological protection standoff from the eastern bank of the boundary ditch.</p> <p>Protection fencing will be erected on the 10m stand off line and will comprise deer exclusion fencing.</p> <p>The restoration soil placement will not extend beyond the line of the fencing.</p>
Boundary K	<p>6m standoff from the gas pipeline.</p> <p>Protection fencing will be erected on the 6m stand off line and will comprise deer exclusion fencing.</p> <p>The restoration soils will not extend beyond the pipeline standoff.</p>
Boundary L	<p>6m standoff from the gas pipeline.</p>

Boundary (as shown on Figure DEC B1)	<b>Boundary standoff design parameters</b> <i>The excavation limit will be at a minimum 2.5m standoff from the protection fencing in all operational areas to provide access for operations.</i>
	<p>The fencing will be erected on the 6m stand off line and will comprise deer exclusion fencing.</p> <p>The restoration soils will not extend beyond the pipeline standoff.</p>
Boundary M	<p>Root Protection Area of 6.9m.</p> <p>10m ecological protection standoff from the eastern bank of the boundary ditch.</p> <p>The fencing will be erected on the 10m stand off line and will comprise amphibian exclusion fence and deer exclusion fence.</p> <p>The restoration soil placement will not extend beyond the line of the fencing.</p>
Boundary N	<p>The fencing will be erected on the site boundary and will comprise amphibian exclusion fence and deer exclusion fence.</p> <p>The restoration soils will extend to the site boundary.</p>
Boundary O	<p>Root Protection Area of 5m (for the hedge which will be planted here along the site boundary).</p> <p>The fencing will be erected 2.5m from the site boundary and will comprise amphibian exclusion fence and deer exclusion fence.</p> <p>The restoration soil placement will not extend beyond the line of the fencing.</p>

- B4. This scheme will be reviewed and updated as necessary as a result of further agreements between the statutory undertakers and Augean. The need for different types of protection fencing will be informed and adapted based on ongoing site monitoring.

**APPENDIX DEC C**

**RELEVANT PARAMETERS FOR WORKS NO 1, NO 2 AND NO 3  
FIGURE DEC C1 WORKS AREAS (DRAWING REFERENCE AU/KCW/07-  
21/22691)**

## Appendix DEC C

## Relevant Parameters for Works No 1, No 2 and No 3

C1. This scheme sets out the relevant parameters for Work No 1, Work No 2 and Work No 3. The Works Areas are shown on Figure DEC C1 (drawing reference AU/KCW/07-21/22691).

Works Area (as shown on Figure DEC C1)	Relevant parameters
Work No 1A	<p><b>Lateral limits</b></p> <p>The authorised works listed in Schedule 1 must not extend beyond the boundary for Work No.1A shown on the works plan (PINS document reference 2.3). The exact layout of the cells will be approved by the Environment Agency as part of the Environmental Permit.</p> <p><b>Vertical limits</b></p> <p><b>Upper limit:</b> +1m Limit of Deviation above the Restored Landform Profile Plan (PINS document reference 2.9).</p> <p><b>Lower limit:</b> As approved by the Environment Agency as part of the detailed design approval under the Environmental Permit.</p>
Work No 1B	<p><b>Lateral limits</b></p> <p>The authorised works listed in Schedule 1 must not extend beyond the boundary for Work No.1B shown on the works plan (PINS document reference 2.3). The exact layout of the cells will be approved by the Environment Agency as part of the Environmental Permit.</p> <p><b>Vertical limits</b></p> <p><b>Upper limit:</b> +1m Limit of Deviation above the Restored Landform Profile Plan (PINS document reference 2.9)</p> <p><b>Lower limit:</b> No deeper than 2m above the top of the Lincolnshire Limestone Formation. The detailed design of each phase will be agreed</p>

<b>Works Area (as shown on Figure DEC C1)</b>	<b>Relevant parameters</b>
	with the Environment Agency as part of the design approval under the Environmental Permit.
Work No 2	<p><b>Lateral limits</b></p> <p>The authorised works listed in Schedule 1 must not extend beyond the boundary for Work No.2 shown on the works plan (PINS document reference 2.3). The exact layout of the cells will be approved by the Environment Agency as part of the Environmental Permit.</p> <p><b>Vertical limits</b></p> <p><b>Height limit of 15m</b></p> <p>The landscape and visual assessment is based on the assumption that there is a visual envelope with a 15m height for the entire footprint of Work No 2 shown on Figure DEC C1. The plant used and located in the waste treatment and recovery facility comprises temporary plant formed of modular units that can be moved to change configuration of the plant or add further technologies as hazardous waste treatment methodologies evolve. The Applicant needs to ensure it can rearrange plant and machinery in response to operational needs if and when necessary, so is not proposing to submit a detailed layout plan for approval. However, the existing layout at the time the application is submitted is shown on the General arrangement plan: Work No 2 (PINS document reference 2.5).</p>
Work No 3	<p><b>Lateral limits</b></p> <p>The authorised works listed in Schedule 1 must not extend beyond the boundary for Work No.3 shown on the works plan (PINS document reference 2.3).</p>

<b>Works Area (as shown on Figure DEC C1)</b>	<b>Relevant parameters</b>
	<p><b>Height limit of 8m</b> The landscape and visual assessment is based on the assumption that there is a visual envelope with an 8m height for the entire footprint of Work No 3 shown on Figure DEC C2. The tallest building within the Work No 3 area is at a height of 8m. The assessed envelope allows flexibility if further temporary offices/buildings are necessary in the future so is not proposing to submit a detailed layout plan for approval. It is considered highly unlikely that another building of 8m in height will be necessary. However, the existing layout at the time the application is submitted is shown on the General arrangement plan: Work No 3 (PINS document reference 2.6).</p>



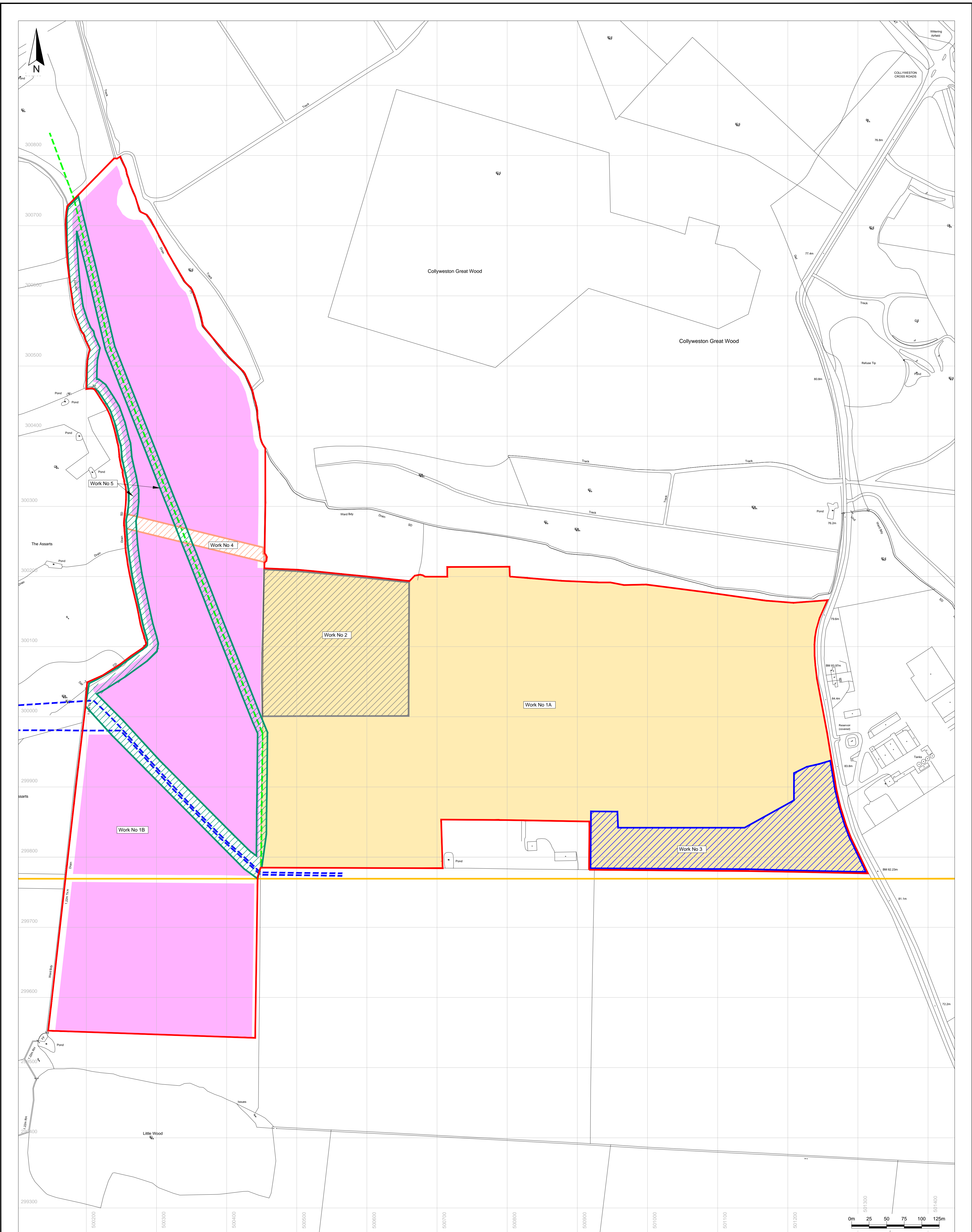

**Key / Notes**

- Boundary of the area the subject of the application for the Development Consent Order
- Approximate route of water pipelines
- Approximate route of an overhead electricity cable (to be diverted)
- Approximate location of a high pressure gas pipeline

Rev	Final	KR	SPS	LH	26/07/21
Rev	Status	Drn	App	Chk	Date
Site EAST NORTHANTS RESOURCE MANAGEMENT FACILITY					
Client					
Title Work Areas					
Figure DEC C1				Scale 1:2,500 @ A1	
Drawing Ref AUJKCW07-21/22691					
Reproduced scale mapping by permission of Ordnance Survey on behalf of The Controller of Her Majesty's Stationery Office. © Crown copyright 2017. All rights reserved. Licence number 100017818.					

**APPENDIX DEC D**

**PHASING SEQUENCE**

**TABLE DEC D1 ANTICIPATED PHASING SEQUENCE FOR THE CONTINUED  
OPERATION OF EAST NORTANTS RESOURCE MANAGEMENT FACILITY  
FIGURE DEC D1 ILLUSTRATIVE PHASE BOUNDARIES FOR THE EXISTING  
ENRMF AND THE WESTERN EXTENSION (DRAWING REFERENCE  
AU/KCW/07-21/22692)**

## Appendix DEC D

### Phasing sequence

- D1. The areas within the Existing Landfill Facility and the Proposed Western Extension will continue to be operated in a series of phases which are extracted, constructed, filled and restored progressively. The phases of the landfill facility are developed generally in a similar sequence in order that completed areas are covered with a low permeability capping layer and restored as soon as possible taking into account operational constraints such as stockpiling. At any one time the previous completed area of landfilling would be undergoing capping, soil placement and restoration planting while landfilling is taking place in the operational phase. Concurrent with these operations the next phase would be being excavated and engineered in preparation for landfilling.
- D2. The approximate locations of each of the phases are shown on Figure DEC D1 (drawing reference AU/KCW/07-21/22692). The detailed design of each landfill phase will be subject to the preparation of a detailed engineering design which will be submitted to the Environment Agency for approval under the Environmental Permit prior to its construction. During the preparation of the final design, the principles set out in this document will be adhered to but minor amendments which are not material in land use terms may be made to take into account details of the phase-specific geology, drainage, ecology and information on other features such as the precise location of services.
- D3. The phasing order for the proposed western landfill area has been finalised following responses to the pre-application consultation and is designed to achieve the completion of the northern area of the proposed western extension at the earliest opportunity. The overall phasing sequence including that for the existing ENRMF landfill is summarised here and in Table DEC D1.

**D4. First stage:** At the time that the new Order is granted filling will be partially complete in the eastern parts of Phases 7, 8 and 9 and construction of Phase 11 will not have commenced in the existing ENRMF landfill. Following grant of the new Order and the completion of preparatory works the northern area of the proposed western extension will be extracted, constructed, filled, capped and restored starting in the north and working south (Phases 12 to 14 as shown on Figure DEC D1). This will allow the early development of habitats on the restored site which are designed to link and provide habitat continuity between the woodlands either side of the northern section of the site. During this period the stockpile on the current site will be gradually reduced and the current site areas will be restored as the areas currently occupied by the stockpile are released. The only stockpile area which will remain in the current site area is in the south east corner as shown on the plan provided with the Stockpile Management Scheme (Appendix DEC J). Materials removed from Phases 12 to 14 which need to be stockpiled on site temporarily will be stockpiled in the area of Phases 19, 20 and 21 as described in the Stockpile Management Scheme (Appendix DEC J). Once Phases 12 to 14 are completed and restored, they will not be disturbed as part of ongoing site operations to the south and they will not be used for stockpiling.

**D5. Second stage:** The southern area of the proposed western extension will be extracted, constructed, filled, capped and restored starting in the south and working north (Phases 15 to 18 as shown on Figure DEC D1).

**D6. Third stage:** Phases 19 to 21 in the central area will be extracted, constructed, filled, capped and restored as the last stage in the western extension area. The landfill in these phases will be joined to the partially completed landfill areas at the western edges of the existing ENRMF landfill (Phases 7, 8 and 9). Towards the end of landfilling in this central area the waste treatment and recovery facility will cease operating and the infrastructure will be removed. Phase 11 will then be prepared for landfilling and will be completed together with the remaining sections of the landfill. The remaining areas of the current site will be restored and all unnecessary infrastructure will be removed.

Table DEC D1

Anticipated phasing sequence for the continued operation of East Northants Resource Management Facility

Key stages	Excavate/engineer	Fill	Cap	Restore	Aftercare
Current (July 2021)	Phases 8 and 9	Phase 7 (except western edge)	Phases 6C and 10	Largest extent of stockpile present	Phases 1 and 2 (north)
<p><b>First stage:</b> Work starts in the north of the western extension (Phase 12) estimated Q4 2023/Q1 2024</p> <p>Filling is completed in the current landfill in all but the western area of Phases 7, 8 and 9 and the treatment plant area (Phase 11)</p> <p>The majority of the eastern and central areas of the current site are restored</p>	Phases 12 to 15.	Phases 8 and 9 (except western edge) and Phases 12 to 14	Phase 7, 8 and 9 (eastern areas). Phases 12 to 14	Remainder of current ENRMF site except Phases 4B and 5B, Phase 11 and the western edge of Phases 7, 8 and 9. Phases 12 and 13.	Phases 1 to 3, 4A, 5A, 6, 7(east) to 9(east), 10 and 12 to 13
<p><b>Second stage:</b> The final part of the northern most phase in the western extension (Phase 14) is restored.</p> <p>Completion of engineering and filling starts at the southern end of the western extension (Phase 15) working northwards to Phase 18.</p>					
	Phases 15 to 19	Phases 15 to 18	Phases 15 to 18	Phase 14. Phases 15 to 17	Phases 1 to 3, 4A, 5A, 6, 7(east) to 9(east) ,10 and 12 to 17

Key stages	Excavate/engineer	Fill	Cap	Restore	Aftercare
Restoration is completed in the area to the south of the gas pipeline (Phases 15 to 17)					
<b>Third stage:</b> Completion of engineering and filling starts in the central area of the western extension (Phases 19, 20 and 21) and continues to complete the adjacent landfilling in the eastern sections of Phases 7, 8 and 9.	Phases 19 to 21 and Phase 11	Phases 19 to 21, western edge of Phases 7, 8 and 9 and Phase 11	Phases 19 to 21, western edge of Phases 7, 8 and 9 and Phase 11	Phases 18 to 21. Remainder of Phases 7, 8 and 9. Phase 11. Phases 4B and 5B	The whole site area is restored and in aftercare at the end of this stage.
Restoration is completed in the area to the south of the water pipelines (Phase 18)					
Work is carried out to remove the treatment plant and excavate and construct Phase 11					
Waste acceptance ceases. Removal of temporary haul roads etc. Removal of all infrastructure not needed for aftercare and monitoring. Construction of car park.					
December 2046					Landfilling complete and all phases in aftercare

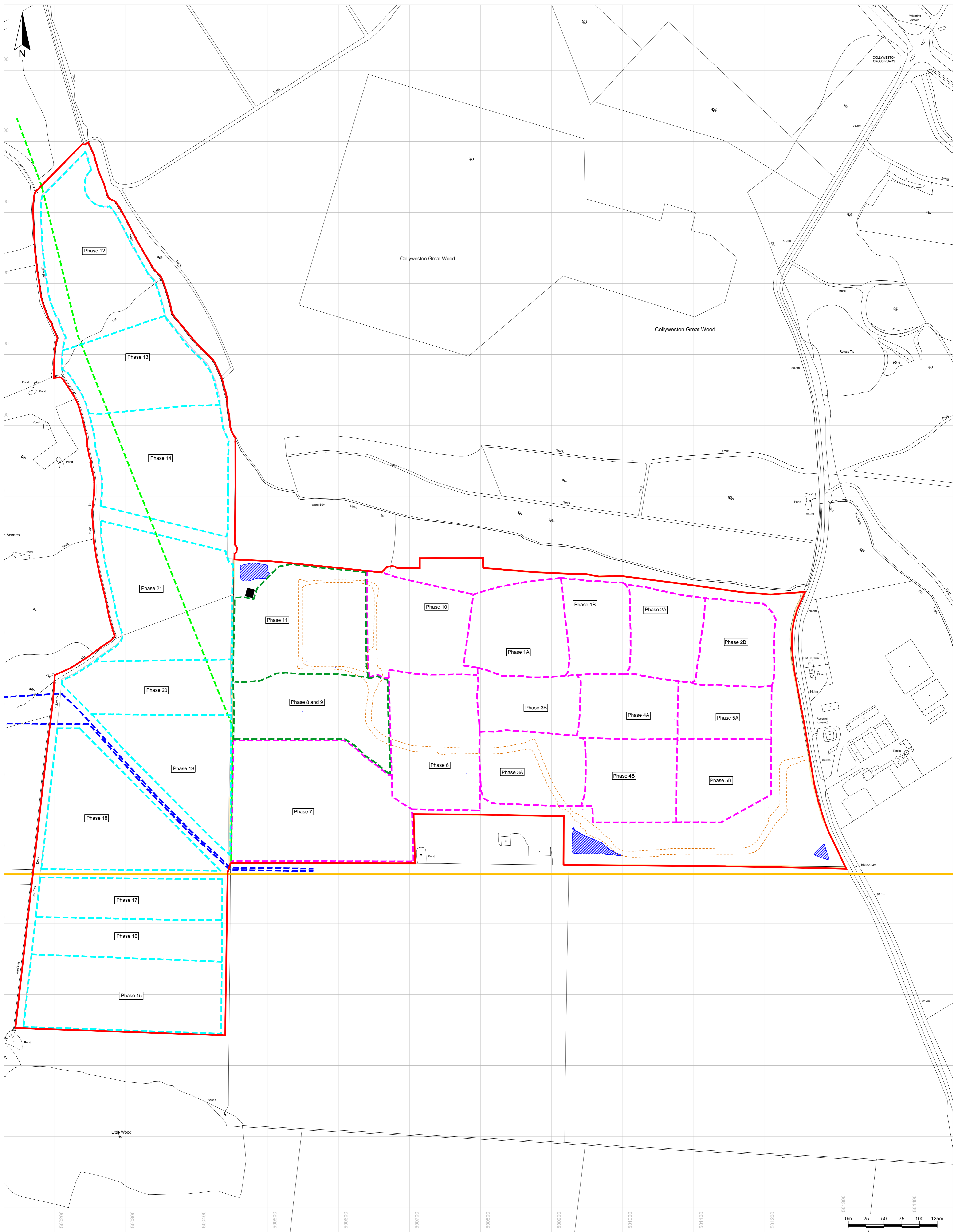

**Key / Notes**

- ▭ Boundary of the area the subject of the application for the Development Consent Order
- ▭ Approximate phase boundaries for the existing ENRMF already constructed
- ▭ Approximate phase boundaries for the existing ENRMF to be constructed
- ▭ Approximate phase boundaries to be constructed in the proposed western extension
- ▭ Approximate route of water pipelines
- ▭ Approximate route of an overhead electricity cable (to be diverted)
- ▭ Approximate location of a high pressure gas pipeline
- ▭ Constructed surface water management ponds
- ▭ Site access/main haul road
- ▭ Gas flare

Rev	Final	KR	SPS	LH	26/07/21
Rev	Status	Drn	App	Chk	Date
Site: EAST NORTANTS RESOURCE MANAGEMENT FACILITY Client:					
Title: Illustrative phase boundaries for the existing ENRMF and proposed western extension Figure DEC D1      Scale: 1:2,500 @ A1 Drawing Ref: AUJKCW07.21/22692 Reproduced scale mapping by permission of Ordnance Survey on behalf of The Controller of Her Majesty's Stationery Office. © Crown copyright 2017. All rights reserved. Licence number 100017818.					

**APPENDIX DEC E**  
**ECOLOGICAL MANAGEMENT, MONITORING AND AFTERCARE PLAN**



**ECOLOGICAL MANAGEMENT,  
MONITORING AND AFTERCARE  
PLAN FOR HABITATS CREATED  
DURING THE OPERATION AND  
RESTORATION OF THE EXTENDED  
EAST NORTHANTS RESOURCE  
MANAGEMENT FACILITY, KING'S  
CLIFFE**



**Final  
July 2021**

---

## DOCUMENT CONTROL

TITLE: Ecological Management, Monitoring and Aftercare Plan for habitats created during the operation and restoration of the extended East Northants Resource Management Facility, King's Cliffe

PROJECT REF: MJCA118

VERSION: Final

DATE: July 2021

AUTHOR(S): Anne Goodall, Luke Hartley, Grant Berky

CHECKED BY: John Pover

APPROVED BY: Anne Goodall

---

ISSUED TO: Leslie Heasman  
MJCA  
Baddesley Colliery Offices  
Main Road  
Baxterley  
Atherstone  
Warwickshire  
CV9 2LE

Sophie Serdetschniy  
MJCA  
Baddesley Colliery Offices  
Main Road  
Baxterley  
Atherstone  
Warwickshire  
CV9 2LE

This report has been prepared by ESL with all reasonable skill, care and diligence, within the terms of the contract with the Client. The report is confidential to the Client. ESL accepts no responsibility of whatever nature to third parties to whom this report may be made known. No part of this document may be reproduced without the prior written approval of ESL.

---

<b>Contents</b>	<b>Page</b>
1. INTRODUCTION	1
1.1 BACKGROUND	1
1.2 OVERALL VISION FOR THE RESTORED SITE	3
1.3 STRUCTURE OF THIS EMMAP	4
2 PRE- CONSTRUCTION ENHANCEMENT AND PROTECTION MEASURES	5
2.1 INTRODUCTION	5
2.2 HEDGEROW ENHANCEMENT	6
2.3 FENCE ERECTION	6
2.4 ENHANCEMENT AND MANAGEMENT OF MARGINS	9
3 MANAGEMENT AND AFTERCARE OF WOODLAND HABITATS	12
3.1 INTRODUCTION	12
3.2 RECOMMENDED PLANTING	15
3.3 DESIGN REQUIREMENTS	17
3.4 OUTLINE PRESCRIPTIONS FOR MANAGEMENT AND AFTERCARE	17
4 MANAGEMENT AND AFTERCARE OF SCRUB HABITATS	19
4.1 INTRODUCTION	19
4.2 RECOMMENDED PLANTING	22
4.3 DESIGN REQUIREMENTS	22
4.4 OUTLINE PRESCRIPTIONS FOR MANAGEMENT AND AFTERCARE	23
5 MANAGEMENT AND AFTERCARE OF HEDGEROW HABITATS	24
5.1 INTRODUCTION	24
5.2 RECOMMENDED PLANTING	27
5.3 DESIGN REQUIREMENTS	28
5.4 OUTLINE PRESCRIPTIONS FOR MANAGEMENT AND AFTERCARE	29
6 MANAGEMENT AND AFTERCARE OF GRASSLAND HABITATS	31
6.1 INTRODUCTION	31
6.2 RECOMMENDED PLANTING	34
6.3 OUTLINE PRESCRIPTIONS FOR MANAGEMENT AND AFTERCARE	36
7 MANAGEMENT AND AFTERCARE OF WETLAND HABITATS	37
7.1 INTRODUCTION	37
7.2 RECOMMENDED PLANTING	41
7.3 DESIGN REQUIREMENTS	41
7.4 OUTLINE PRESCRIPTIONS FOR MANAGEMENT AND AFTERCARE	42

---

8	MONITORING METHODS AND OPERATIONAL PRESCRIPTIONS	43
8.1	RATIONALE AND AIMS	43
8.2	SPECIES-RICH GRASSLAND	44
8.3	WETLANDS	45
8.4	AMPHIBIANS	45
8.5	REPTILES	46
8.6	INVERTEBRATES	46
8.7	MAMMALS	47
8.8	BIRDS	48
9	REPORTING AND REVIEW	51
9.1	PRESCRIPTIONS FOR REPORTING AND REVIEW	51
10	REFERENCES AND BIBLIOGRAPHY	56
	APPENDIX 1	58



---

# ECOLOGICAL MANAGEMENT, MONITORING AND AFTERCARE PLAN FOR HABITATS CREATED DURING THE OPERATION AND RESTORATION OF THE EXTENDED EAST NORTHANTS RESOURCE MANAGEMENT FACILITY, KING'S CLIFFE

## 1. INTRODUCTION

### 1.1 BACKGROUND

1.1.1 The Scoping Opinion for the East Northants Resource Management Facility (ENRMF) proposed Western Extension provided by the Planning Inspectorate (the Inspectorate) on behalf of the Secretary of State (SoS) in August 2020 includes the following comments:

**ID 4.2.3 Mitigation and enhancement measures and management/action plans**

*The ES should include or refer to an appropriate draft restoration and management plan and/or action plan with respect to ecology and biodiversity, such as a draft Ecological and Landscape Management Plan and/or Biodiversity Action Plan. The plan(s) should include information on proposed ecological mitigation and enhancement measures for the Proposed Development, together with proposed management and monitoring measures.*

*The Applicant should make effort to ensure the landscape design avoids habitat fragmentation and provides green corridors for the movement of species where possible.*

*The Inspectorate welcomes the intention to discuss the habitats to be included in the restoration proposals with Natural England. The Applicant should also make effort to agree the restoration with other relevant consultation bodies, such as the County Ecologist at Northamptonshire County Council (NCC) and the MoD.*

1.1.2 The ecological impact assessment (ESL, 2021) carried out for this development found that no significant adverse impacts would result from it. Significant biodiversity enhancement and biodiversity net gain is proposed as part of the

---

restoration of the Site. In order to demonstrate that the biodiversity enhancement and biodiversity net gain are being achieved, monitoring and management will be undertaken once the habitats are established at the Site. This document provides the required Ecological Monitoring, Management and Aftercare Plan (EMMAP) for the entire Site. The Site for the purpose of this document is the existing ENRMF and the proposed Western Extension (shown on Figure 1).

1.1.3 This EMMAP is based on and will replace the EMAP originally prepared for the ENRMF site under the East Northamptonshire Resource Management Facility Order 2013 amended by the East Northamptonshire Resource Management Facility (Amendment) Order 2018 (Original Order). It is intended that the EMMAP for the Site will apply from the date a notice is served on the relevant planning authority pursuant to Article 4 of the Development Consent Order (DCO) (Application Reference 3.1) in order to establish the pre-construction enhancement and protection measures and then to manage the habitats as the Site is restored. This EMMAP has been produced through regular consultation with national and local bodies including Natural England, Forestry England, Butterfly Conservation/Back from the Brink (Roots of Rockingham), the Bedfordshire, Cambridgeshire and Northamptonshire Wildlife Trust and the North Northamptonshire Council Ecologist.

1.1.4 Species and species groups, identified by these bodies and other specialists, form the target species for the Site as set out in Appendix 1.

1.1.5 This EMMAP is intended to ensure:

- That appropriate pre-construction enhancement and protection measures are implemented.
- That the habitats created through the restoration scheme will meet the descriptions of the Priority Habitats in the Natural Environment and Rural Communities Act, 2006 (NERC) Section 41 and deliver the Biodiversity Net Gain for the Site.
- That the restoration of the proposed Western Extension area creates habitat connectivity between the existing woodlands adjoining the Site and

---

the wider area, with suitable green corridors for the movement of all relevant species.

- That following completion of the operations, the Site provides an area for informal quiet recreation for visitors.

## 1.2 OVERALL VISION FOR THE RESTORED SITE

- 1.2.1 When mature, the Site (as defined in para 1.1.2 above) will carry fairly-open mixed lowland woodland, with much grassland of various types forming glades, rides and paths through the more wooded areas. There will be a network of unpaved footpaths, providing the potential for linking where possible to existing footpaths in the wider area. To achieve this (and to provide resilience in the face of ongoing climate change and other possible future impacts, such as tree diseases and invasive predatory invertebrates), the initial planting will create a wood-pasture/meadow with clumps and stands of scrub and woodland of various sizes and with linking treelines.
- 1.2.2 The woody planting will comprise a wide range of tree and shrub species known to be present and healthy in local woods, planted in different mixtures in different areas. Initially, native trees known or expected to cope with the conditions they may meet will be planted however, any species arriving in the future will be accepted, monitored and managed where necessary.
- 1.2.3 The local woods are known to have deer populations of several species and the blocks of woodland and scrub will therefore need to be fenced initially. Fencing will be removed once the growing tips of trees and bushes are clear of browse height. It is envisaged that mowing of paths and glades will be needed at least in the early years following restoration.
- 1.2.4 A number of species and species groups have been selected as targets for monitoring; these are believed to give a wide indication that the new habitats are meeting the expectations expressed by consultees throughout the planning consultation process. These species are listed in Appendix 1.
- 1.2.5 Further species/groups may be added in later iterations of this EMMAP, once there are habitats mature enough to attract them.

---

## 1.3 STRUCTURE OF THIS EMMAP

- 1.3.1 Restoration will be carried out in accordance with the principles described in the Environmental Statement and shown on the Restoration Concept Scheme (PINS document reference 2.8) and will follow the general phasing sequence set out in the Phasing Sequence Table in the DCO Environmental Commitments document (or any changes later agreed). The duration of each phase will be dictated by external factors and it is possible that changes may occur to the order in which phases are constructed, filled and restored. Notwithstanding this, it is a commitment in the application that the northern area of the proposed Western Extension will be restored first in order to commence restoration of this area at the earliest practical opportunity and deliver optimum linkage between the adjacent woodlands as soon as possible. Some habitats take longer to establish than others and establishment times for the same habitat may also vary over the Site subject to factors such as gradient, aspect and soil type. The EMMAP therefore assumes that the start date for ecological management of any restored area of habitat will be determined by the completion of planting and its establishment. Prescriptions for management and monitoring are therefore based on the stage of growth/maturity of each area of habitat and not on the phasing.
- 1.3.2 Prior to the commencement of the operations in the proposed Western Extension, it is proposed to undertake enhancement and protection work. These works are described in Section 2 below. The following sections each concentrate on a particular habitat, providing details of target species/groups for each habitat to be created and managed. Prescriptions for this management and the necessary monitoring are also given in each section. Detailed methods are then provided and tables set out the annual and seasonal management and monitoring required for the first five years of the EMMAP after which, there will be an established management regime.
- 1.3.3 The EMMAP would be in place for the 20-year aftercare period. It is proposed that the EMMAP be reviewed every five years with both monitoring and management updated as necessary. Any additional actions that are identified as necessary further to those set out in the EMMAP will be reflected in the



---

phasing, landscape and restoration plan submitted under Requirement 4 of the DCO.

## **2 PRE- CONSTRUCTION ENHANCEMENT AND PROTECTION MEASURES**

### **2.1 INTRODUCTION**

2.1.1 To ensure that enhancement measures provide benefit as soon as possible, a number of measures will be undertaken prior to the commencement of the operations in the proposed Western Extension area (see Figure 2). These works will include:

- Planting a new species-rich native hedgerow parallel to the existing patchy hedgerow/largely dead treeline along the northwest and northern boundary of the north field of the proposed Western Extension to improve connectivity for dormice, larval habitat for butterflies and food sources for invertebrates (see Figure 2).
- Creating a bank and planting a new hedgerow/treeline along the southeast boundary of the southern field to the west of the farm track. This will, in time, provide wind-shelter and connectivity with the utility corridors.
- Strengthening the southern boundary of the existing ENRMF by gapping-up with suitable species where work in this area is complete (and continuing as these phases are completed) to provide further connectivity, extending to the roadside hedgerow.
- Installation of fencing to prevent deer and badgers, which currently use the arable field, from injury through falling into the void of the proposed Western Extension once construction begins.
- Adding an external herpetofauna exclusion fence on the woodland side of the deer fence to similarly prevent great crested newts (GCN) and reptiles from straying into the development area and being injured by construction traffic once they begin to use the newly enhanced marginal habitat.
- Enhancement of the existing marginal field edge, currently part grass/part arable, between this new fence and the redline boundary of the Site by

sowing a suitable seed mix for invertebrates and reptiles, planting small areas of scrub for cover and constructing refuges and hibernation sites.

- 2.1.2 The hedgerow planting may begin before the DCO is granted but at the latest, it will be carried-out in the first planting season after the DCO is granted. Work to protect GCNs and reptiles in the first operational areas will be implemented as soon as the relevant licence is granted.

## 2.2 HEDGEROW ENHANCEMENT

- 2.2.1 The hedgerows/tree-lines along the northwest and north sides of the northern field of the proposed Western Extension are gappy and growing out. While some parts of this habitat still provide useful features, the whole hedgerow is in need of enhancement. To provide this, a second species-rich hedgerow, including standard trees, will be planted parallel to it on its eastern/south-eastern side. The hedgerow along the south side of the ENRMF is also gappy in places and needs strengthening by gapping-up where necessary.

### **Operational prescriptions for hedgerow enhancement.**

OP2.1 Two years after establishment and gapping are completed, lay the hedgerow, using any wood removed to gap-up the existing hedgerow or form wood piles for invertebrates etc. in the marginal grassland.

OP2.2 Erect deer fencing along the new hedgerow, ensuring that it is higher than the lead shoots.

OP2.3 Examine the hedgerow annually for the first five years, replacing fencing as necessary where deer browsing is apparent and gapping-up where needed.

OP2.4 Survey the hedgerow regularly through the spring and summer and record use by target species and other pollinators.

## 2.3 FENCE ERECTION

- 2.3.1 The fields in the proposed Western Extension are crossed and used for feeding by muntjac, roe and fallow deer. The northern field of the proposed Western Extension in particular is also used by badgers. All these species can be expected to try to continue using the field and therefore, to be at risk of falling

into the landfill cells. To avoid this risk, it will be necessary to erect an exclusion fence around each phase before operations commence in each phase.

- 2.3.2 There is no evidence that amphibians, reptiles or small mammals use the northern fields of the proposed Western Extension at present but assuming the enhancement of the margin is successful, it is possible that any of these animals could use the land up to the fence. To exclude them from the working area, a herptile exclusion fence will be erected close to or as part of the larger deer/badger fence.
- 2.3.3 There is currently newt exclusion fencing and perimeter security fencing at the existing ENRMF. The existing protective fencing in the existing ENRMF will remain in place and be removed as necessary as the restoration operations progress.
- 2.3.4 The erection of protective fencing around the operational areas of the proposed Western Extension will be carried out progressively as the Site development proceeds in a phased manner. The principles of the phased development in general terms are that the northern area of the proposed Western Extension will be developed and completed first from north (Phase 12) to south (Phase 14). The southern part of the extension will then be operated and completed from south to north (Phase 15 to Phase 18). The final section of the Site to be operated will be the central sections of the proposed Western Extension (Phases 19 to 21), which will include the completion of the adjoining areas of Phases 7 to 9 and Phase 11 in the existing ENRMF site.

Operational Area	Fencing types needed
Phases 1 – 11.	Site security fencing. Newt exclusion fencing.
Phases 12 to 14 in the northern area of the proposed Western Extension including any haul road or other operational areas.	10m standoff area from the inner bank of the boundary ditches apart from one area in the northeast of the proposed Western Extension where the standoff is 30m. Amphibian exclusion fencing. Deer exclusion fencing. Badger exclusion fencing.

Operational Area	Fencing types needed
<p>Phases 15 to 17 in the southern area of the proposed Western Extension.</p>	<p>10m standoff from the western woodland boundary ditch.</p> <p>5m standoff from the eastern boundary hedgerow to be planted to the west of the farm track.</p> <p>No standoff needed from the southern boundary.</p> <p>Amphibian and deer exclusion fence all around the area.</p>
<p>Phase 18.</p>	<p>10m standoff from the western woodland boundary ditch.</p> <p>No standoff needed from the southern and north-eastern boundaries.</p> <p>Deer exclusion fence all around the area.</p>
<p>Phases 19 to 21 in the central area of the proposed Western Extension.</p>	<p>10m standoff from the western and north-western woodland boundary ditch.</p> <p>No standoff needed from the northern boundary. The eastern boundary will be continuous with the operational area of the existing ENRMF.</p> <p>Amphibian, deer and badger exclusion fence all around the outer boundary of the area.</p>

2.3.5 The proposed fencing is shown on Drawing 1.

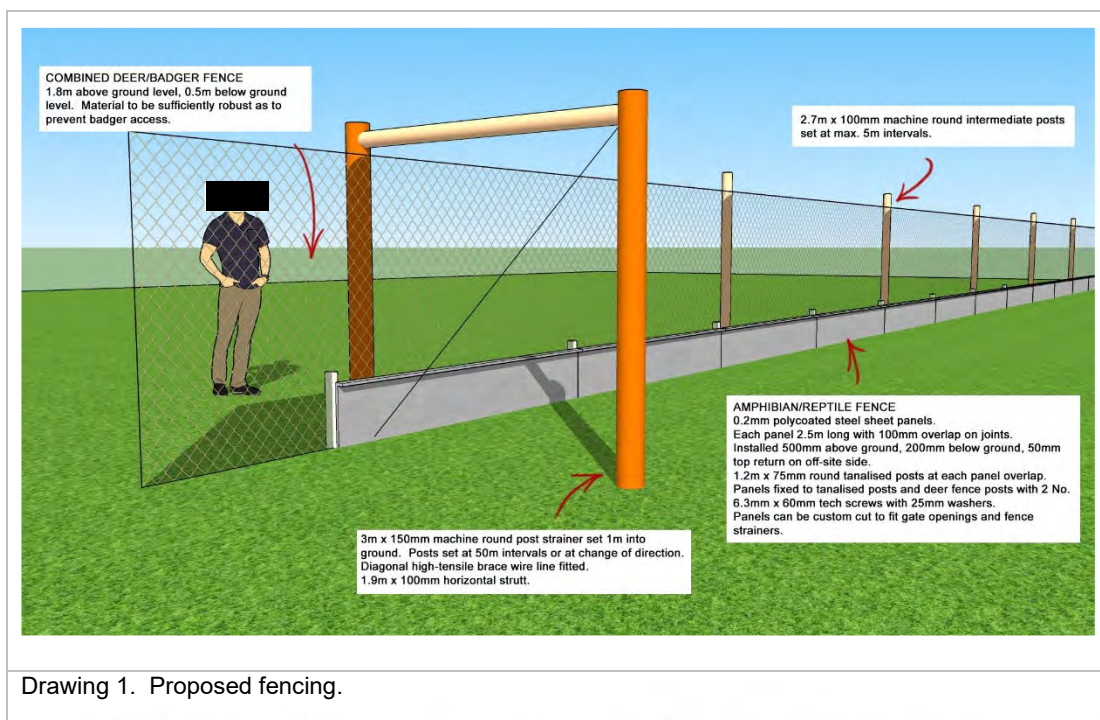

### Operational prescriptions for fence erection.

OP2.5 Lay-out the route-line and instruct contractors on erection of exclusion fence progressively around the proposed Western extension works. Supervise trenching etc. if it is not on arable to protect reptiles or amphibians.

OP2.6 Supervise manual location of straining posts to ensure that no major tree roots are damaged.

OP2.7 Agree an inspection regime with site staff. Check the fencing regularly for signs of damage, trim and apply glyphosate to the herptile fence, repair as needed and report major damage to site staff.

## 2.4 ENHANCEMENT AND MANAGEMENT OF MARGINS

2.4.1 Invertebrate surveys have shown that both margins and especially the eastern margin of the northern field of the proposed Western Extension, adjacent to Collyweston Great Wood, have important invertebrate populations. All margins are also used by the common reptiles and there are records of adder near the western margin (adjacent to Fineshade Woods) very occasionally.



Drawing 2 Indicative view of enhanced margin.

---

2.4.2 At the moment, this western margin of the proposed Western Extension is narrow and species-poor, with little good reptile habitat. The northern margin of the proposed Western Extension is similar, as is the northern part of the eastern margin of the proposed Western Extension, although the grassland here widens towards the scrubby area at the south end. This habitat is particularly important for both invertebrates and common reptiles.

2.4.3 It is therefore considered likely that enhancing this margin by seeding a more species-rich grassland mix will enhance both the invertebrate and reptile populations. This enhanced margin, adjacent to Collyweston Great Wood, is shown in Drawing 2 (above). Provision of tussock-forming grasses attractive to basking adders and wood piles for hibernacula and basking areas will attract all reptiles and possibly also amphibians:

OP2.7 Agree with local ecologists a suitable seed mix for this purpose.

OP2.8 Acquire and spread this seed mix at a suitable time of year.

OP2.9 Locate the area occupied by the glow-worm colony and if necessary, adjust mowing locally to suit its requirements.

OP2.10 Collect deadwood and any rocks, stone and/or bricks available and use this material to construct piles at intervals around the edges of the margins.

OP2.11 Once the grassland is established, mow the 6m closest to the fence annually in late autumn, in lengths on rotation, to maintain a height of 50-150mm. Maintain the woodland edge grassland, containing the wood-piles etc. no shorter than 200-300mm, encouraging grass tussocks and brambles to invade. ■■■■

OP2.12 As the phases of the proposed Western Extension are completed and restored and the fence removed, the margin will be taken into the general grassland management, including allowing scrub and trees to invade.

**Table 1. Requirements of Species Provided or Protected by the Pre-Construction Measures.**

Species and Targets	Requirements	Habitat Creation and Management
<p><b>Reptile assemblage, common.</b></p> <p>Seek to increase populations of the common reptile species throughout the western margin of the proposed Western Extension during this EMMAP.</p> <p>Once restored habitat is available, secure connectivity between margin and new habitat areas.</p>	<p>Mosaic of generally open habitats with access to cover, including woodland edge.</p> <p>Invertebrate-rich habitats for foraging.</p> <p>Compost and woodchip heaps for egg-laying and incubation.</p> <p>Hibernation sites.</p>	<p>Provide species-rich grassland for invertebrates and clumps of rough grassland for basking and cover.</p> <p>Provide low bramble and other low shrubs around the margins to provide basking sites and cover.</p> <p>Retain all woody arisings on site in the form of brush piles, log-piles etc. or integrated into new hibernacula.</p> <p>Design areas of new woodland as it develops to provide south and west-facing basking areas.</p> <p>Retain arisings from grassland management as grass heaps for egg-laying.</p> <p>Link woodland and scrub patches by hedgerow creation.</p>
<p><b>Reptile assemblage, adder.</b></p> <p>Expand current population of adder into the marginal zone; seek to establish adders along the western margin of the proposed Western Extension during this EMMAP.</p>	<p>Mosaic of generally open habitats with access to cover, including woodland edge.</p> <p>Invertebrate-rich habitats for foraging.</p>	<p>As for reptile assemblage.</p>
<p><b>Dormouse.</b></p> <p>Suitable habitat to be present with signs of small mammal use by</p>	<p>Dense scrub or hedgerows with a wide variety of flower, fruit- and nut-producing shrubs and trees, including</p>	<p>Provide suitable woody and scrub habitat along the western side of the Site during the period of this EMMAP.</p>

Species and Targets	Requirements	Habitat Creation and Management
<p>completion of this EMMAP period.</p> <p>Secure connectivity between marginal and new woodland habitats, encouraging spread of populations.</p>	<p>bramble, honeysuckle and wild roses, in an intimate mosaic for feeding and nesting.</p> <p>Holes under trees for hibernation.</p>	<p>Ensure hedgerows, scrub and woodland patches all provide at least eight different woody species/ha.</p> <p>Link new woodland and scrub patches by hedgerow creation.</p>
<p><b>Invertebrate assemblage.</b></p> <p>Suitable habitat to be present and colonised by a good range of woodland butterflies, including white-letter hairstreak and black hairstreak and flower-feeding adults of saproxylic species by the end of this EMMAP.</p> <p>Seek to expand the glow-worm colony.</p> <p>Expand number and species of pollinator species through the duration of this EMMAP.</p>	<p>Specific larval food plants (or invertebrates) where known.</p> <p>A good range of flowering shrubs, trees, bushes and wildflowers to provide choice to pollinators.</p> <p>Sheltered conditions for feeding.</p>	<p>Provide a wide mixture of grassland types, including tussocky grassland growing up into bramble or other low scrub and species-rich flowering plants.</p> <p>Provide larval food plants for butterfly larvae and nectar species for adults.</p> <p>Locate the extent of the glow-worm colony, identify important structures and seek to expand these.</p>

### 3 MANAGEMENT AND AFTERCARE OF WOODLAND HABITATS

#### 3.1 INTRODUCTION

3.1.1 Lowland Mixed Deciduous Woodland is a UK and Northamptonshire Biodiversity Action Plan (LBAP: available at [www.northamptonbiodiversity.org](http://www.northamptonbiodiversity.org)) Priority Habitat (now a Habitat of Principal Importance for Biodiversity as described in Section 41 of NERC).

3.1.2 'Woodland' comprises a number of communities, including canopy trees, understorey trees, ground flora, standing and lying deadwood, glades and rides. All these communities can provide habitat for the following species and species assemblages identified as target species for this EMMAP:



- Reptile assemblage, comprising slow worm, common lizard, grass snake and adder.
- Dormouse.
- Bats.
- Invertebrate species assemblage.
- White letter hairstreak and chequered skipper butterflies.

3.1.3 The ecological requirements that can be provided by woodland habitats for each species or group are given in Table 2 below.

**Table 2. Ecological Requirements of Target Species Provided by Woodland Habitats.**

Species and Targets	Ecological Requirements	Habitat Creation and Management
<p><b>Reptile assemblage, common.</b></p> <p>Seek to increase populations of the common reptile species throughout the woodlands during this EMMAP.</p> <p>Continue to secure and extend connectivity between margin and new woodland habitat areas.</p>	<p>South-facing edges of rides and glades with access to woodland or scrub cover, including woodland edge.</p> <p>Invertebrate-rich habitats for foraging.</p> <p>Compost and woodchip heaps for egg-laying and incubation.</p> <p>Hibernation sites.</p>	<p>Provide species-rich grassland for invertebrates in rides and glades and clumps of rough grassland for basking and cover.</p> <p>Provide low bramble and other low shrubs around scrub and woodland margins for basking sites and cover.</p> <p>Retain all woody arisings on site in the form of brush piles, log-piles etc. or integrated into new hibernacula.</p> <p>Retain arisings from grassland management as grass heaps for egg-laying.</p> <p>Link woodland and scrub patches by hedge creation.</p>
<p><b>Reptile assemblage, adder.</b></p> <p>Expand current population of adder, seeking to establish new basking areas</p>	<p>Mosaic of generally open habitats with access to cover, including woodland edge.</p> <p>Invertebrate-rich habitats for foraging.</p>	<p>As for reptile assemblage.</p>

Species and Targets	Ecological Requirements	Habitat Creation and Management
along the woodland margins.		
<p><b>Dormouse.</b> Suitable scrub habitat to be present with signs of small mammal use by completion of this EMMAP period. Secure connectivity between scrub and woodland patches both in the existing and new woodland areas., encouraging spread of populations.</p>	<p>Dense scrub or understorey patches with a wide variety of flower, fruit- and nut-producing shrubs and trees, including bramble, honeysuckle and wild roses, in an intimate mosaic for feeding and nesting. Holes under trees for hibernation.</p>	<p>Provide suitable woody and scrub habitat throughout the restored areas during the period of this EMMAP. Ensure scrub and woodland understorey patches all provide at least eight different woody species/ha. Link new woodland and scrub patches by hedgerow creation.</p>
<p><b>Bats.</b> All the target species are already present in adjacent woodland and can be expected to use the new areas as soon as they are mature, particularly for commuting at first, later for feeding.</p>	<p>Good populations of flying invertebrates, including moths Good numbers of leaf-eating insects for gleaning bats. Sheltered conditions for feeding and for commuting to feed elsewhere. Old trees with cavities for roosting.</p>	<p>Provide sheltered edges to glades, rides and woodland edges. Provide suitable food sources for flying insects. Ensure that layout of clumps and particularly hedgerows provide east-west connections.</p>
<p><b>Invertebrate assemblage</b> Suitable habitat to be present and colonised by a good range of woodland butterflies including white-letter hairstreak, black hairstreak and flower-feeding adults of saproxylic species by the end of this EMMAP. Expand number and species of pollinator species through the</p>	<p>Specific sites for egg-laying and larval food plants where known. A good range of flowering shrubs, trees, bushes and wildflowers to provide choice to pollinators. Sheltered conditions along glade and ride edges and along joining hedgerows for feeding.</p>	<p>Provide a wide mixture of grassland types, including tussocky grassland growing up into bramble or other low scrub and species-rich flowering plants. Provide larval food plants for butterfly larvae and nectar species for adults.</p>

Species and Targets	Ecological Requirements	Habitat Creation and Management
duration of this EMMAP.		

## 3.2 RECOMMENDED PLANTING

### Canopy and understorey species.

- 3.2.1 The following species are present in the ancient semi-natural stands present in Collyweston Great Wood and/or Fineshade Woods and/or are target species named in the Northants wildlife site criteria (Northamptonshire Biodiversity Partnership, 2007, Updated 2014). Certain species listed below have specific soil requirements and prior to reuse and placement, top-soil testing will be carried out and a protocol will be prepared for soil mixing and adaption where needed based on the type of habitat that is to be developed in the area of restoration to which the soil will be directed.
- 3.2.2 Conifers are not normally included in lowland mixed deciduous woodland but they are beneficial to most birds in small clumps for winter roosting and are also used by certain specialist nesting birds. They also increase site resilience and will therefore be included within proposed planting. There is an opportunity to create an area of wet woodland in Swallow Brook.

### Broadleaves

alder <i>Alnus glutinosa</i>	aspen <i>Populus tremula</i>
blackthorn <i>Prunus spinosa</i>	crab apple <i>Malus sylvestris</i>
dogwood <i>Cornus sanguinea</i>	field maple <i>Acer campestre</i>
goat willow <i>Salix caprea</i>	hawthorn <i>Crataegus monogyna</i>
hazel <i>Corylus avellana</i>	holly <i>Ilex aquifolium</i>
hornbeam <i>Carpinus betulus</i>	Midland hawthorn <i>Crataegus laevigata</i>
pedunculate oak <i>Quercus robur</i>	sessile oak <i>Quercus petraea</i>

silver birch <i>Betula pendula</i>	small-leaved lime <i>Tilia cordata</i>
sweet chestnut <i>Castanea sativa</i>	wild cherry <i>Prunus avium</i>
wild service tree <i>Sorbus torminalis</i>	

### Conifers

larch <i>Larix decidua</i>	Scot's pine <i>Pinus sylvestris</i>
yew <i>Taxus baccata</i>	

### Additional requirements for Target species

bramble <i>Rubus</i> sp.	honeysuckle <i>Lonicera periclymenum</i>
wild roses <i>Rosa</i> sp.	

### Tree species for Wet Woodland

Grey willow <i>Salix cinerea</i>	Eared willow <i>Salix aurita</i>
downy birch <i>Betula pubescens</i>	aspen <i>Populus tremula</i>
goat willow <i>Salix caprea</i>	alder <i>Alnus glutinosa</i>

### Ground flora species.

3.2.3 Initial herbaceous planting under the canopy can comprise any grass mixture suitable for the soil type in order to protect and warm the soil and contribute humus. With one exception, it is unlikely to be useful to try to incorporate specifically woodland plants at this stage. The rides and glades should be sown with the same grassland mix as for the meadows, with the addition of wood false brome *Brachypodium sylvaticum*, purple moor grass *Molinia caerulea* and wood small-reed *Calamagrostis epigejos* (the larval food plants of chequered skipper) and bugle *Ajuga reptans* (the preferred nectar plant of the adults) in the grassed margin around woodland blocks on the west side of the fields.

3.2.4 Given its small area, ground-flora species for the wet woodland will be best sourced from an existing area. Wet woodlands tend to be rich in lichens, mosses, tall grasses and ferns.

---

### 3.3 DESIGN REQUIREMENTS

- 3.3.1 Woody trees will be planted in small, random patches throughout the restored areas of the Site initially and managed as part of a wood meadow complex. Gradual encroachment of these areas by self-set seedlings will be encouraged to fill and connect the adjacent stands.
- 3.3.2 At least 40% of the total woodland area will be maintained as open rides and glades. So far as possible, glades will be orientated east-west and be wider than the height of the adjoining woodland canopy. Rides will be laid out to follow the route of footpaths, to bend away from the prevailing wind directions once they enter the wood to avoid creating wind tunnels.
- 3.3.3 Rides and glades should have scalloped edges (up to 30m long and 10-20m deep). The south and south-west facing edges of the wood should similarly have scalloped edges. These provide good sheltered feeding areas for invertebrates and species which prey on them.

### 3.4 OUTLINE PRESCRIPTIONS FOR MANAGEMENT AND AFTERCARE

#### **Establishment.**

OP3.1 Initially, plant approximately 20-30% of the restoration area with clumps of canopy and understorey broadleaved and coniferous species.

#### **General prescriptions.**

OP3.2 Trim back or lay stretches of woodland edge, glade edge and ride edge habitats at intervals, in small blocks on an eventual rotation of 8-20 years, to maintain structural diversity.

OP3.3 Use brash from trimming, laying or coppicing to construct deadwood piles in glades and rides and along the woodland edge to provide feeding and basking sites for amphibians and reptiles. Position some piles in shade and others in sunlight to provide a range of conditions for invertebrates.

OP3.4 Unless causing a threat to public safety, leave dead trees where they stand. If felling or limb removal is required, place the felled wood as close as

---

possible to the original position including some semi-buried as a habitat for deadwood invertebrates.

### **Prescriptions for managing grassland habitats within and around woodland.**

OP3.5 Once the grassland habitat is established, mow the central zone of the ride vegetation regularly (depending on usage) to maintain it between 50-100mm and to create a path. Mow opposite sides of the bordering herbaceous zone on a 2-year rotation, between October and March, to not less than 100mm. Mow in short lengths to avoid cutting all the shade or all the sunny vegetation in the same year. Remove arisings (see OP3.7 below).

OP3.6 In the glades, maintain a path or paths for public use, as for the rides, between 50-100mm. Mow the remainder of the central zone to not less than 100mm annually between October and March. Mow the bordering herbaceous zone, within 10m of the woodland margin, to not less than 100mm on a 2-3-year rotation between October and March, in order to provide refuge areas for the overwintering forms of invertebrates.

OP3.7 Pile the arisings from mowing at intervals along the sunny side of the ride or glade to provide egg-laying sites for grass-snakes and habitat for specialist invertebrates.

No management is necessary for ground vegetation in wet woodland habitat.

### **Prescriptions for monitoring.**

OP3.8 Monitor extent of woodland habitat on the restoration area on a 5-year basis.

OP3.9 Starting from the year after the amphibian exclusion fence has been removed, carry out a 'tinning' survey for reptiles in all suitable woodland habitats annually until occupation of this habitat is recorded, then every three years to monitor establishment and spread.

OP3.10 Record all signs and sightings of other target species on all management and monitoring visits.

OP3.11 Include the results from this habitat in the annual and 5-year reports.

---

## 4 MANAGEMENT AND AFTERCARE OF SCRUB HABITATS

### 4.1 INTRODUCTION

4.1.1 Since scrub is not currently identified as a national BAP habitat, there is no specific target for its creation and management however, stands of free-standing scrub are recognised as supporting a large number of species and associations of conservation importance. In particular:

- It complements and links adjacent national and local BAP habitats such as woodland and ponds.
- It provides an intermediate habitat between the open grassland and the woodland areas – an important transitional mixture of habitats.
- Blocks of scrub are used by dormice.
- Many of the woodland species of interest (birds, invertebrates) use the woodland scrub edge habitat.
- Blocks of scrub support breeding birds such as linnet and bullfinch and many bird species use scrub for some part of their ecology (e.g., providing cover when feeding in the open, for nesting and as song posts).
- Tall grasses growing into the base of shrubs and hedgerows are used by wintering invertebrates.
- Scattered scrub in grassland areas provides shelter and creates a warm micro-climate for grassland butterfly species.
- Typical scrub species such as willows and gorse provide an early nectar source for many invertebrate species.

4.1.2 Other than the scrubby area in the southeast corner of the northern field, blocks of scrub are not currently present on the Site. Linear scrub, managed as hedgerows or as woodland or ride-edge habitat, is discussed in other sections. This section considers compact blocks of scrub; these may vary from dense to more open, mixed with rough grassland and may vary in height from <0.5m to 3m. Ideally, rotational management, probably assisted by local wildlife, will keep it in this range. Target species for this five-year plan include:

- Reptile assemblage, comprising slow worm, common lizard, grass snake and adder.

- Dormouse.
- Harvest mouse.
- A good variety of shrub- and hedgerow-nesting birds.
- Invertebrate assemblage.
- Black hairstreak butterfly.

4.1.3 The ecological requirements that can be provided by scrub habitats for each species or group are given in Table 3 below.

**Table 3. Ecological Requirements of Target Species Provided by Scrub Habitats.**

Species and Targets	Ecological Requirements	Habitat Creation and management
<p><b>Reptile assemblage.</b> Continue to encourage expansion of adders in the marginal zone; seek to establish adders around patches of scrub on the edges of the planted mound during this EMMAP. Seek to increase populations of the common reptile species around the edges of the new woodland and scrub areas during this EMMAP.</p>	<p>Mosaic of generally open habitats with access to cover, including woodland edge. Invertebrate-rich habitats for foraging. Compost and woodchip heaps for egg-laying and incubation. Create potential hibernation sites.</p>	<p>Provide species-rich grassland for invertebrates and clumps of rough grassland for basking and cover. Provide low bramble and other low shrubs around the margins to provide basking sites and cover. Retain all woody arisings on site in the form of brash piles, log-piles etc. or integrated into new hibernacula. Design areas of new scrub patches as they develop to provide south- and west-facing basking areas. Retain arisings from grassland management as grass heaps for egg-laying within the scrub Link scrub patches to each other and woodland by short lengths of hedgerow.</p>
<p><b>Harvest mouse.</b> Suitable habitat to be present and colonised</p>	<p>Tall grasses and umbellifers among or edging scrub patches</p>	<p>Provide a minimum 2m-wide margin of tall herbs and grasses around the</p>



Species and Targets	Ecological Requirements	Habitat Creation and management
by completion of restoration.	for building breeding nests. A good variety of fruits, flowers, seeds and shoots of grasses, bramble and umbellifers for foraging.	blackthorn thickets and bramble clumps. Mow tall grassland around dense clumps on rotation over three years to maintain vegetation at a range of heights.
<p><b>Dormouse.</b></p> <p>Suitable habitat to be present and colonised by completion of restoration.</p> <p>Secure connectivity between adjacent habitats allowing distribution and recruitment between populations.</p>	A variety of flower, fruit- and nut-producing shrubs, including bramble and honeysuckle, in an intimate mosaic for feeding and nesting.	<p>Provide a mosaic of woody species and shrub densities.</p> <p>Link all scrub patches to each other and to woodland by short lengths of hedgerow.</p> <p>Rotationally coppice all scrub areas in small patches to maintain shrubby structure and a mosaic of heights.</p>
<p><b>Shrub- and hedgerow-nesting birds.</b></p> <p>Secure habitat that will provide nesting opportunities in the longer term.</p> <p>Feeding habitat close to cover.</p>	<p>Nest sites in dense or patchy scrub, including bramble or in tall grass growing up into the base of bushes.</p> <p>Invertebrates, seeds and fruit for feeding (thrushes also take earthworms, molluscs, fresh fruit).</p> <p>Dense cover for winter roosts.</p>	<p>Provide areas of both dense and more open scrub close to rough grassland, hedgerows and woodland for nesting and foraging.</p> <p>Provide a minimum 2m-wide margin of tall herbs and grasses around the blackthorn thickets and bramble clumps.</p> <p>Rotationally coppice all scrub areas in small patches in late winter to maintain shrubby structure and a mosaic of heights.</p> <p>Mow tall grassland around dense clumps on rotation over three years to maintain vegetation at a range of heights.</p> <p>Maintain areas of damp ground to provide earthworm and snail prey.</p>

Species and Targets	Ecological Requirements	Habitat Creation and management
<p><b>Invertebrate assemblage.</b></p> <p>Suitable habitat to be present and colonised by a good range of butterflies, including black hairstreak aculeate hymenoptera and flower-feeding adults of saproxylic species by the end of this EMMAP.</p> <p>Seek to expand the glow-worm colony.</p> <p>Expand number and species of pollinator species through the duration of this EMMAP.</p>	<p>Specific larval food plants (or invertebrates) where known.</p> <p>A good range of flowering shrubs, trees, bushes and wildflowers to provide choice to pollinators.</p> <p>Sheltered conditions for feeding.</p>	<p>Provide a wide mixture of grassland types, including tussocky grassland growing up into bramble or other low scrub and species-rich flowering plants.</p> <p>Provide larval food plants for butterfly larvae and nectar species for adults.</p> <p>Locate the extent of the glow-worm colony, identify important structures and seek to expand these.</p>

## 4.2 RECOMMENDED PLANTING

### Woody species.

4.2.1 The areas of scrub that are present close to the Site (e.g., on ride edges or glades in the woodland adjacent to the Site), largely comprise:

blackthorn <i>Prunus spinosa</i>	bramble <i>Rubus fruticosus</i> agg.
dog-rose <i>Rosa canina</i>	gorse <i>Ulex europaea</i>
hawthorn <i>Crataegus monogyna</i>	willows <i>Salix</i> spp.

4.2.2 These species should form the bulk of the scrub areas, although most of the species used for hedgerow creation or in the woodland shrub layer are also suitable additions for scrub planting in lower concentrations.

## 4.3 DESIGN REQUIREMENTS

4.3.1 Around 25% of the total scrub area should comprise dense blackthorn (particularly favoured by nesting linnets and bullfinches and important for black

---

hairstreaks) or bramble (used by nesting dunnocks, thrushes and several warbler species; also important to dormice and many invertebrates). The remainder should be more open, varying from 20-50% density. The ground flora in these areas should be a mosaic of tussocky grassland (used by some nesting birds and by overwintering invertebrates) and more open ground for basking.

- 4.3.2 All scrub patches should have scalloped edges to maximise the range of micro-habitats for invertebrates.

#### **4.4 OUTLINE PRESCRIPTIONS FOR MANAGEMENT AND AFTERCARE**

##### **Prescriptions for managing dense scrub areas.**

OP4.1 Maintain scrub areas between 0.5-3m high by rotational coppicing of either small areas of large clumps or individual small clumps over a ca.5-year cycle.

OP4.2 Maintain bramble clumps at 0.5-1.5m high by cutting back 20% of the resource annually on a 5-year rotation.

OP4.3 Maintain a minimum 2m-wide margin of tall herbs and grasses around all scrub and bramble areas and prevent them from spreading by rotational mowing around each area in autumn over a 3-year period.

OP4.4 Remove all brush and arisings or use them to construct deadwood and grass piles along the woodland edge, as for woodland management.

##### **Prescriptions for managing less dense scrub areas.**

OP4.5 Maintain all other scrub areas between 1-3m by rotational coppicing over a ca.5-7-year cycle, to provide a mosaic of heights in each area.

OP4.6 Mow grassland around the scrub patches and between the bushes in scattered scrub on a 2-year rotation, between October and March, to not less than 100mm.

OP4.7 Leave grassland below the canopy of each bush unmown in order to provide refuge areas for the overwintering forms of invertebrates.

OP4.8 Pile the arisings from mowing at intervals along the margins of the scalloped areas to provide egg-laying sites for grass-snakes and invertebrates.

#### **Prescriptions for monitoring.**

OP4.9 Starting for each restored phase from the year after the amphibian exclusion fence has been removed, carry out a 'tinning' survey for reptiles in all suitable scrub habitats annually until occupation of this habitat is recorded, then every three years to monitor establishment and spread.

OP4.10 Once the habitat is established, take it into the dormouse monitoring programme for the Site.

OP4.11 Record all signs and sightings of other target species on all management and monitoring visits.

OP4.12 Include the results from this habitat in the annual and five-year reports.

## **5 MANAGEMENT AND AFTERCARE OF HEDGEROW HABITATS**

### **5.1 INTRODUCTION**

5.1.1 Hedgerows are currently present along the east, south and west boundaries of the existing ENRMF and along the west, north and through the centre of the proposed Western Extension but they are species-poor and lack standard trees. Rockingham Forest Joint Conservation Area is a specific target area for hedgerows in the Northants LBAP and the planned restoration work will contribute to the following LBAP targets:

- No net loss of hedgerows.
- Restore appropriate management to 50% of hedgerows not currently under agri-environmental schemes by 2020.  
Increase the number of new, young hedgerow trees by 800 by 2025 (equal to rejuvenating or planting 40km of hedgerow).
- Increase the extent of species-rich hedgerows by 40km by 2025. New hedgerows to include hedgerow trees.

5.1.2 Habitats provided by hedgerows include the woody shrubs themselves, hedgerow trees and ground flora under the trees and on the hedgerow bank,

providing a range of conditions and niches. These communities provide habitat for the following BAP Priority Species and species assemblages previously identified as target species for the five-years of this EMMAP:

- Reptile assemblage, comprising slow worm, common lizard, grass snake and adder.
- Brown hare.
- Harvest mouse.
- Dormouse.
- A good variety of shrub- and hedgerow-nesting birds.
- Invertebrate assemblage.
- Black hairstreak butterfly.

5.1.3 The ecological requirements that can be provided by woodland habitats for each of these target species or groups are given in Table 4 below.

5.1.4 Improving existing hedgerows and planting new double-hedgerows on each side of the doline corridor and the utilities corridors extending across the Site will also provide movement lanes between wooded areas, scrub, ponds, the hay meadow grassland and wider countryside. In this way, hedgerows form the backbone to the success of the restoration plan and will also assist survival and spread of a number of other species not selected as specific targets, including hedgehogs.

**Table 4. Ecological Requirements of Target Species Provided by Hedgerow Habitats.**

Species and Targets	Ecological Requirements	Habitat Creation and management
<p><b>Reptile assemblage.</b> Once populations of both adders and the more common reptile species have moved onto the new habitat, hedgerows will be critical to restoration of connectivity between the woodlands.</p>	<p>Mosaic of generally open habitats with access to cover, including woodland edge.</p> <p>Invertebrate-rich habitats for foraging.</p> <p>Compost and woodchip heaps for</p>	<p>Provide species-rich grassland for invertebrates and clumps of rough grassland for basking and cover at the base of all hedgerows.</p> <p>Retain all woody arisings on site in the form of brush piles, log-piles etc. or integrated into new hibernacula.</p>

Species and Targets	Ecological Requirements	Habitat Creation and management
	<p>egg-laying and incubation.</p> <p>Creation of potential hibernation sites.</p>	<p>Retain arisings from grassland management as grass heaps for egg-laying within the scrub.</p> <p>Link scrub patches to woodland via new hedgerow creation.</p>
<p><b>Harvest mouse.</b></p> <p>Suitable habitat to be present and colonised by completion of restoration.</p>	<p>Tall grasses and umbellifers among hedgerow ground flora for building breeding nests.</p> <p>A good variety of fruits, flowers, seeds and shoots of grasses, bramble and umbellifers for foraging.</p>	<p>Provide a minimum 1-2m-wide margin of tall herbs and grasses around the base of hedgerows, particularly around blackthorn thickets and bramble clumps.</p> <p>Mow tall grassland along hedgerows on rotation over three years to maintain some vegetation at a suitable height.</p>
<p><b>Dormouse.</b></p> <p>Suitable habitat to be present and colonised by completion of restoration.</p> <p>Secure connectivity between adjacent habitats, allowing distribution and recruitment between populations.</p>	<p>A variety of flower, fruit- and nut-producing shrubs, including bramble, wild roses and honeysuckle in an intimate mosaic for feeding and nesting.</p>	<p>Provide a mosaic of woody species and shrub densities.</p> <p>Link all scrub patches to each other and to woodland by hedgerow creation.</p> <p>Cut hedgerows on rotation in small lengths to maintain shrubby structure and a mosaic of heights.</p>
<p><b>Shrub- and hedgerow-nesting birds.</b></p> <p>Secure habitat that will provide nesting and feeding opportunities.</p>	<p>Nest sites in dense hedgerows, with tall grass growing up into the base of bushes.</p> <p>Invertebrates and seeds for feeding (thrushes also take earthworms, molluscs and fresh fruit).</p> <p>Dense cover for winter roosts.</p>	<p>Provide hedgerows of a variety of density and height through the Site, especially close to rough grassland suitable for foraging.</p> <p>Provide a minimum 1-2m-wide margin of taller herbs and grasses along the length of each hedgerow.</p> <p>Trim hedgerows on a 5-year rotation (20% of total length over the whole Site) to 1.5m in late winter.</p>

Species and Targets	Ecological Requirements	Habitat Creation and management
		Mow grassland close to hedgerows on rotation over three years to maintain vegetation at a range of heights.
<p><b>Invertebrate assemblage.</b></p> <p>Suitable habitat to be present and used by a good range of butterflies, pollinators such as aculeate hymenoptera and flower-feeding adults of saproxylic species by the end of this EMMAP.</p>	<p>Specific larval food plants where known.</p> <p>A good range of flowering shrubs, trees, bushes and wildflowers to provide choice to pollinators.</p> <p>Sheltered conditions for feeding.</p>	<p>Provide a wide mixture of grassland types, including tussocky grassland growing up into bramble or other low scrub and species-rich flowering plants.</p> <p>Provide seed-laying shrubs and larval food plants for butterfly larvae and nectar species for adults.</p>

## 5.2 RECOMMENDED PLANTING

### Woody species.

5.2.1 A species-rich hedgerow should contain six or more species per 30m from the following list, with at least one standard tree every 50m. Suitable standard trees are indicated as (std); oaks should comprise at least 40% of standard trees.

alder (std) <i>Alnus glutinosa</i>	alder buckthorn <i>Frangula alnus</i>
blackthorn <i>Prunus spinosa</i>	buckthorn <i>Rhamnus cathartica</i>
crab apple (std) <i>Malus sylvestris</i>	hawthorn <i>Crataegus monogyna</i>
dog-rose <i>Rosa canina</i>	holly <i>Ilex aquifolium</i>
dogwood <i>Cornus sanguinea</i>	pedunculate oak (std) <i>Quercus robur</i>
elms <i>Ulmus</i> spp.	
field maple (std) <i>Acer campestre</i>	
guelder-rose <i>Viburnum opulus</i>	
goat willow <i>Salix caprea</i>	

hazel <i>Corylus avellana</i>	
Midland hawthorn <i>Crataegus laevigata</i>	
sessile oak (std) <i>Quercus petraea</i>	
small-leaved lime (std) <i>Tilia cordata</i>	
spindle <i>Euonymus europaeus</i>	
wild cherry (std) <i>Prunus avium</i>	
wild privet <i>Ligustrum vulgare</i>	
wild service tree (std) <i>Sorbus torminalis</i>	
wych elm (std) <i>Ulmus glabra</i>	

#### **Additional requirements for target species.**

bramble <i>Rubus</i> sp.	honeysuckle <i>Lonicera periclymenum</i>
--------------------------	--

#### **Ground flora species.**

5.2.2 As with woodland, trying to incorporate woodland ground flora is unlikely to be useful at this stage. Initial herbaceous planting should comprise any wildflower grass mixture suitable for the soil type in order to protect and warm the soil and contribute humus.

### **5.3 DESIGN REQUIREMENTS**

5.3.1 All new hedgerows should comprise a double row of shrubs and should meet the minimum species requirement for UK BAP species-rich hedgerows (see 5.2.1). They should be planted on banks at least 250mm high, 1-1.5m wide and with a 30-50degree slope to provide safe movement corridors for amphibians, reptiles and small mammals and to extend the range of micro-climates for invertebrates.



- 
- 5.3.2 Where suitable, a south-facing bank carrying a hedgerow on the south side of a wood, footpath or utility corridor could be steep-faced and left unplanted to provide nest-sites for solitary bees and basking sites for reptiles.
- 5.3.3 Hedgerows linking scrub and woodland and hedgerows running along the woodland side of the footpath should include a high proportion of species favoured by dormice, such as hazel, hawthorn, bramble, honeysuckle and wild roses. These hedgerows will be suitable as laid hedgerows. The optimal stem diameter for laying is 5-10cm with a hedgerow height of 2-3m.
- 5.3.4 The hedgerows alongside the footpaths and boundaries should be managed as an 'A' shape, which reduces self-shading and promotes thick growth at the hedgerow base.

## 5.4 OUTLINE PRESCRIPTIONS FOR MANAGEMENT AND AFTERCARE

### Prescriptions for management of woody species.

OP5.1 Maintain all hedgerows between 1.5m and 2.5m high by cutting on rotation.

On all hedgerows, cut either opposite sides or short lengths of both sides on a 2-year rotation between December and the end of February to allow the shrubs to flower and set seed/nuts or berries.

OP5.2 Gap-up as necessary to replace dead shrubs, using native species from the approved list to maintain or improve species diversity, between October and March.

OP5.3 Monitor health and safety of standard trees, instigating management if necessary, on safety grounds and replacement for any trees that fail to thrive.

Retain woody arisings close to the hedgerow or within one of the areas of woodland or scrub.

OP5.4 Once the growth has reached 2m, maintain the hedgerows immediately adjacent to footpaths open to the public by laying them over winter, avoiding periods of hard frost.

---

OP5.5 Lay suitable lengths on rotation to maintain a range of different heights and structures, allowing the regrowth to reach not more than 2m before laying again.

**Prescriptions for management of the banks and grassed verges.**

OP5.6 Maintain strips of rough grassland along both sides of the internal hedgerows; provide a minimum 2m-wide margin of tall herbs and grasses adjacent to these hedgerows, where there is no path, mown on a 3-year rotation with arisings removed or piled to create egg-laying sites for grass snakes.

OP5.7 Where a hedgerow accompanies a path, provide a minimum strip of tall grassland 1m-wide between the footpath and hedgerow.

Mow grassland between the path and hedgerow annually to a height not less than 150mm after seed-set, with a further cut in late autumn if needed.

Add arisings to the grass snake egg-laying sites in the glades and rides of the woodland.

**Prescriptions for monitoring.**

OP5.8 Starting from the year after the amphibian exclusion fence has been removed, carry out a 'tinning' survey for reptiles in sections of hedgerow closest to the boundaries annually until occupation of this habitat is recorded, then throughout the hedgerow network every three years to monitor establishment and spread.

OP5.9 Once the habitat is established, take it into the dormouse monitoring programme for the site.

OP5.10 Record all signs and sightings of other target species on all management and monitoring visits.

OP5.11 Include the results from this habitat in the annual and five-year reports.

---

## 6 MANAGEMENT AND AFTERCARE OF GRASSLAND HABITATS

### 6.1 INTRODUCTION

6.1.1 Areas of grassland on the Site are currently restricted to the north slope of the existing ENRMF and the narrow strips of semi-improved or rough grassland along the boundary hedgerows and around arable land of the proposed Western Extension. The existing ENRMF was originally arable farmland and the proposed Western Extension still is. Since grassland will be a major habitat, particularly during the earlier years, all larger areas will be treated as lowland meadows. These are a UK and LBAP priority habitat and creation of such grassland on Site will contribute to the following Northamptonshire target:

- Create 80ha of LWS-standard lowland meadow from arable or improved grassland by 2020.

6.1.2 Most of the grassland created on this Site will be neutral, although some south-facing areas and those that already have important invertebrate populations will have calcareous grassland. This grassland has its own suite of scarce and highly-local species, some of which prefer the short grassland associated with typical chalk grassland flowers but many prefer longer grass and even calcareous scrub so management for both plants and invertebrates should aim to achieve a good mosaic of sub-habitats.

6.1.3 Species-rich neutral grassland also provides invaluable habitat for invertebrates, including spiders and molluscs, with nectar sources including knapweed, yarrow, clovers and trefoils and weed seedlings for feeding. They also provide seeds, grain and weed seedlings for winter bird flocks to feed on. Rough grasslands are not a national BAP habitat but they are recognised as providing excellent intermediate habitat between habitats such as scrub and ponds. They are a source of nectar, pollen and seeds for pollinating invertebrates and seed-eating birds and tussocky rough-grassland strips provide an important habitat for small mammals.

6.1.4 The grassland habitats will also help to link adjacent habitats. BAP Priority Species and species assemblages previously identified as target species for this period of the EMMAP are:

- Reptile assemblage, comprising slow worm, common lizard, grass snake and adder.
- A good variety of shrub- and hedgerow-nesting birds.
- Invertebrate assemblage.
- Grizzled skipper, dingy skipper, small heath butterflies and cinnabar moth.

6.1.5 The ecological requirements that can be provided by grassland habitats for each species or group are given in Table 5 below. While many of these requirements are (also) filled by rough or marshy grassland, this section deals only with the management of meadow grasslands.

**Table 5. Ecological Requirements of Target Species Provided by Grassland Habitats.**

Species and Targets	Ecological Requirements	Habitat Creation and management
<p><b>Reptile assemblage.</b> The target for this group and particularly for adder is to create connectivity between the populations of the two woodlands bordering the restoration area. The variety of grassland types achievable within the restoration scheme is key to doing this; careful monitoring of preferences and adjusting management will be important.</p>	<p>Mosaic of generally open habitats with a range of grass height and type and access to cover, including patches of scrub, hedgerows and woodland edge.</p> <p>Invertebrate-rich habitats for foraging.</p> <p>Compost and woodchip heaps for egg-laying and incubation.</p> <p>Hibernation sites.</p>	<p>Provide species-rich grassland for invertebrates and clumps of rough grassland for basking and cover at the base of all woody habitats.</p> <p>Retain all woody arisings on site in the form of brash piles, log-piles etc. or integrated into new hibernacula.</p> <p>Retain arisings from grassland management as grass heaps for egg-laying within the scrub.</p> <p>Link scrub patches to woodland via new hedgerow creation or grassy banks.</p>
<p><b>Shrub- and hedgerow-nesting birds.</b></p>	<p>Areas of ground vegetation rich in seeds</p>	<p>Provide a mosaic of flower-rich grassland</p>

Species and Targets	Ecological Requirements	Habitat Creation and management
Provide prey-rich feeding areas for increasing numbers and species of a range of farmland birds as the habitat matures.	and invertebrates, including earthworms and snails, close to suitable cover for feeding in summer and winter.	attractive to a range of pollinator species, spiders, beetles and other invertebrates. Mow grassland close to woody stands on rotation over three years to maintain vegetation at a range of heights for use by wintering stages of insects. Trim hedgerows and scrub edges bordering grassland on a 5-year rotation (20% of total length over the whole site) to 1.5m in late winter to provide nuts and berries for winter feeding.
<p><b>Invertebrate assemblage.</b></p> <p>Suitable habitat to be present and used by a good range of butterflies, pollinators such as aculeate hymenoptera and flower-feeding adults of saproxylic species by the end of this EMAP.</p>	<p>Specific larval food plants (or invertebrates) where known.</p> <p>A good range of flowering shrubs, trees, bushes and wildflowers to provide choice to pollinators.</p> <p>Sheltered conditions for feeding.</p>	<p>Provide a wide mixture of grassland types, including tussocky grassland growing up into bramble or other low scrub and species-rich flowering plants.</p> <p>Provide larval food plants for butterfly larvae and nectar species for adults.</p>
Dingy skipper.	Open grassland, particularly on south-facing chalk or limestone hillsides, with bird's-foot trefoil.	Use BMV soil to create suitable conditions around the south side of scrub clumps on west-facing slopes. Eggs laid singly on upper side of food plant leaf.
Grizzled skipper.	Open ground in meadows or woods with agrimony, barren strawberry, wild	Eggs laid singly on leaves of food plants. Create open areas in sunny glades and wood

Species and Targets	Ecological Requirements	Habitat Creation and management
	strawberry, creeping cinquefoil and bramble.	edges and introduce larval food plants.
Small heath butterfly.	All types of grassy areas with meadow-grasses and fescues. Adults visit knapweeds and thistles.	Eggs laid singly on grass blades just above ground level. Maintain some areas with long grass and flowers all year.
Cinnabar moth.	Any type of open grassland containing ragworts (the larval foodplant). Adults feed on nectar by day, from a range of flowers.	Eggs laid in batches (30+) on the underside of ragwort leaves. Ragwort spreads best in more open grassland.

## 6.2 RECOMMENDED PLANTING

6.2.1 The lowland meadows should eventually meet the Northamptonshire LWS standard for neutral grassland (see [www.northamptonshirebiodiversity.org](http://www.northamptonshirebiodiversity.org)), with at least 50 grassland species in total, of which at least eight should be neutral grassland indicator species however, the LCS list includes species of both dry and wet habitats, also some that prefer shade and others that are more suited to rough grasslands. Therefore, although it is likely that several different native seed mixtures or green hay from a local species-rich grassland would be needed to obtain this variety, some of the species will colonise naturally and not all need be present specifically in every area of grassland. Achieving the standard for **calcareous** grassland is very likely to mean collecting and spreading green hay in the BMV soil areas but will be worth it since many of the calcareous indicator species are host plants for target butterfly species.

### Flowering plants.

6.2.2 The following Northamptonshire indicator species for neutral grassland would be beneficial to one or more of the target species:

agrimony <i>Agrimonia eupatoria</i>	common bird's-foot trefoil <i>Lotus corniculatus</i>
-------------------------------------	--

common knapweed <i>Centaurea nigra</i>	common sorrel <i>Rumex acetosa</i>
cowslip <i>Primula veris</i>	cuckoo-flower <i>Cardamine pratensis</i>
common fleabane <i>Pulicaria dysenterica</i>	hoary ragwort <i>Senecio erucifolius</i>
*lady's bedstraw <i>Galium verum</i>	meadow crane's-bill <i>Geranium pratense</i>
meadow vetchling <i>Lathyrus pratensis</i>	oxeye daisy <i>Leucanthemum vulgare</i>
perforate St.-John's-wort <i>Hypericum perforatum</i>	

6.2.3 The following 'strong indicator' species would be particularly valuable to include but should not be planted unless their local provenance can be guaranteed, otherwise, they would be better introduced as green hay from a local high-quality grassland, as seeds collected or plug plants grown from seeds collected from local native meadows.

*betony <i>Stachys officinalis</i>	*devil's-bit scabious <i>Succisa pratensis</i>
*field scabious <i>Knautia arvensis</i>	great burnet <i>Sanguisorba officinalis</i>
marsh-marigold <i>Caltha palustris</i>	marsh ragwort <i>Senecio aquaticus</i>
*rough hawkbit <i>Leontodon hispidus</i>	tormentil <i>Potentilla erecta</i>
*yellow-rattle <i>Rhinanthus minor</i>	

\* plants that are also 'strong indicators' of calcareous grassland.

### Grasses.

6.2.4 Most of the grasses should comprise fine-leaved species, including fescues *Festuca* spp., meadow-grasses *Poa* spp. and bents *Agrostis* spp., which are important food plants for the small heath butterfly and other invertebrates. Other grasses typical of hay meadows that could usefully be included are:

crested dog's-tail <i>Cynosurus cristatus</i>	yellow oat-grass <i>Trisetum flavescens</i>
---	---

crested hair-grass <i>Koeleria macrantha</i>	
sweet vernal-grass <i>Anthoxanthum odoratum</i>	

### 6.3 OUTLINE PRESCRIPTIONS FOR MANAGEMENT AND AFTERCARE

#### Prescriptions for management of meadows.

OP6.1 For areas to be treated as summer meadows:

Take an early cut in March-April (to a height not less than 150mm in order to protect early moving amphibians and reptiles), removing all arisings. Shut the meadow up through the summer and take a hay crop in late summer.

Mow at least twice more through autumn, removing arisings.

OP6.2 For areas to be treated as spring meadows:

Mow for the last time each autumn in October, removing arisings and shut the meadow up at that point. Take a hay crop in late summer.

Mow at least twice more until October, removing arisings.

OP6.3 When cutting, leave an uncut area several metres wide along one edge of each meadow to act as a refuge for beneficial insects. This margin should be rotated around the field each year to prevent incursion of scrub or ruderal species.

OP6.4 If stock is available to graze the meadow, substitute grazing for autumn cutting of the aftermath between August and October and for the 'early bite' of the summer meadow in March-April.

6.3.1 Prescriptions for monitoring meadow grasslands are given in paragraph 8.2



---

## 7 MANAGEMENT AND AFTERCARE OF WETLAND HABITATS

### 7.1 INTRODUCTION

7.1.1 Provided they meet at least one of the criteria on ecological quality, ponds (defined as permanent or seasonal standing waterbodies up to 2ha in extent) are a UK and Local Northamptonshire Priority Habitat. The Northamptonshire BAP defines 'seasonal' as holding water for more than four months of the year. The ecological criteria include ponds supporting:

- Species of 'High' conservation importance: Red Data Book species, UK BAP species, species listed on Schedules 5 or 8 of the Wildlife and Countryside Act, 1981 (and as amended) or Annex II of the Habitats Directive, a Nationally Scarce wetland plant or three Nationally Scarce aquatic invertebrate species.
- Exceptional assemblages of key biotic groups, based either on criteria for selection as SSSI or at least 30 wetland plants or 50 aquatic invertebrate species.

7.1.2 The Northamptonshire BAP has set targets to:

- Achieve wildlife-friendly management of 50 ponds by 2020.
- Create 50 wildlife-friendly ponds by 2020.

7.1.3 The new permanent ponds to be created comprise a series of small waterbodies along the southern boundary of the existing ENRMF, a deepened area of the water-attenuation basin in the northern corner of the proposed Western Extension northern field and a new surface water course, Swallow Brook, replacing a currently buried pipeline along the doline. Swallow Brook will remain connected to wet areas to the west, will include several deeper areas intended to hold water permanently in most years and will also function as an attenuation area if needed (see drawings 3 and 4).

7.1.4 There will also be a number of surface water attenuation basins intended to hold water after heavy rainfall, then release it. For most of the time, these basins are expected to be empty.

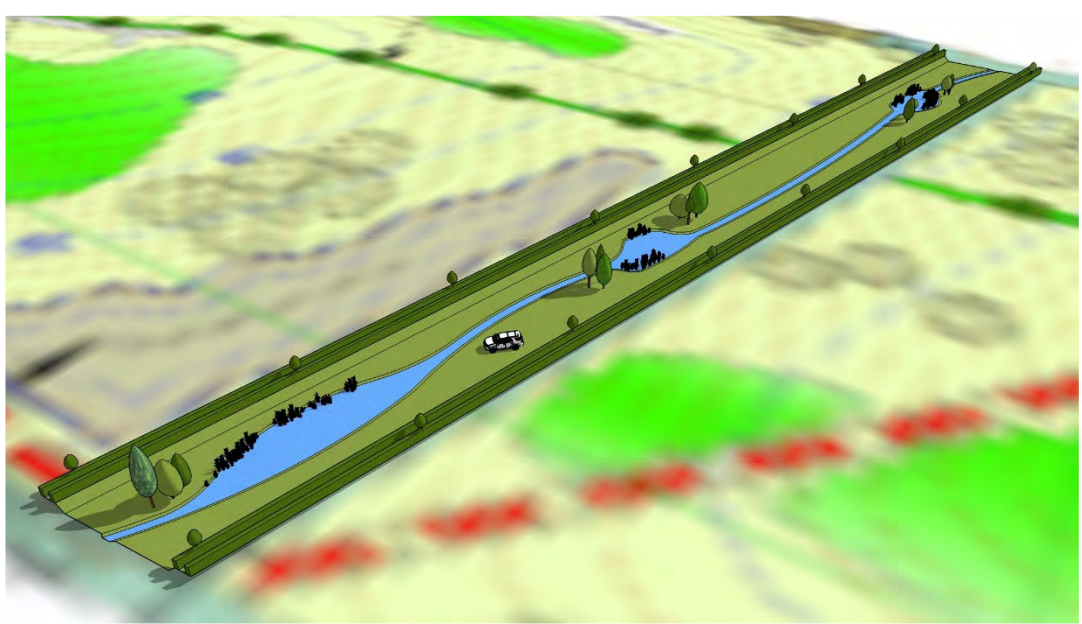

Drawing 3 Swallow Brook

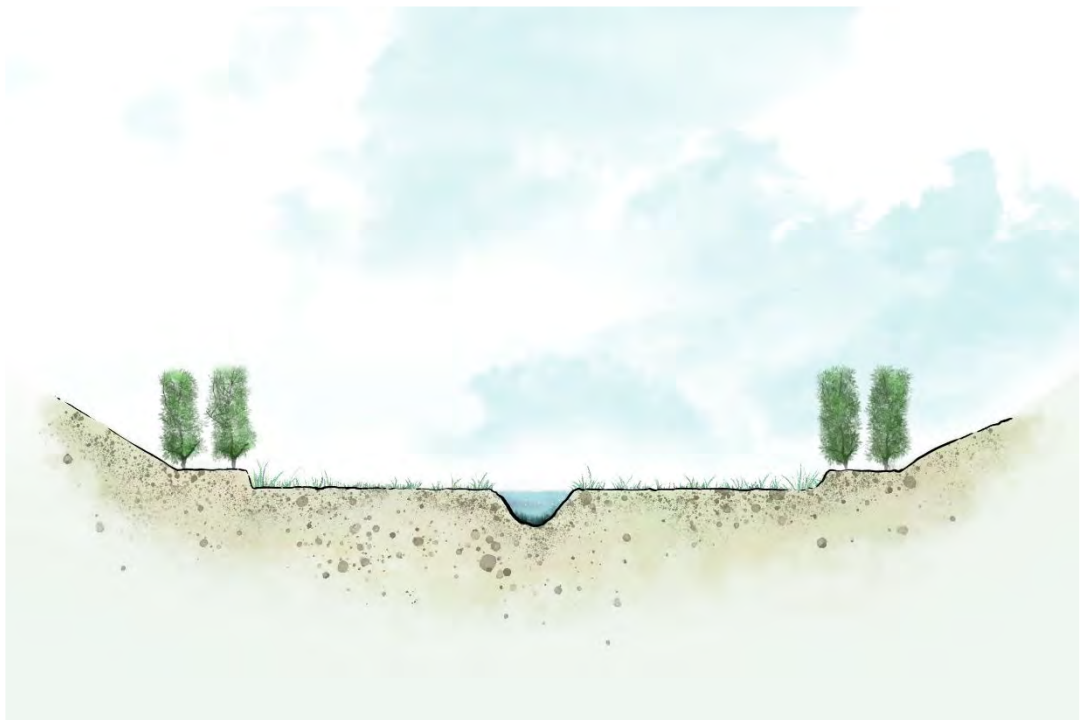

Drawing 4 Swallow Brook, indicative cross-section through the channel.

7.1.5 The new ponds to be created, including their surrounding wet grassland areas and adjacent scrub, will provide habitat for the following BAP Priority Species and species assemblages identified as target species for the first five years of this EMMAP:

- Amphibian species assemblage, including GCN and common toad (UK and LBAP species) and palmate newt (LBAP species).
- Grass snake.
- Bat assemblage, including noctule, soprano pipistrelle, barbastelle and brown long-eared bat.
- Shrub- and hedgerow-nesting birds, particularly reed bunting.
- Invertebrate assemblage.

7.1.6 The ecological requirements that can be provided by wetland habitats for each species or group are given in Table 6 below.

**Table 6. Ecological Requirements of Target Species Provided by Wetland Habitats.**

Species and Targets	Ecological Requirements	Habitat Creation and management
<p><b>Amphibian assemblage.</b></p> <p>Populations of all five common species are known to use a number of the existing ponds in areas close to the site. Secure connectivity between adjacent habitats improves distribution and recruitment between these population; the target is to have at least one new pond or ditch in use before the end of the first EMMAP.</p>	<p>Ponds without fish or wildfowl, retaining enough water through four summers out of 50 to allow animals to complete their life cycle. At least 60% of surface to be unshaded with some deep water. A range of aquatic plant species suitable for egg-laying and good numbers of aquatic invertebrates.</p>	<p>Build refuges and hibernacula using bricks, rubble, logs, etc. as available, close to each new pond. Ensure pond surroundings include tussocky tall herbs and grasses, scrub and deadwood for feeding, shelter and hibernation. Ensure suitable habitat connectivity between ponds including scrub, hedgerows, tall herbs and grasses</p>
<p><b>Grass snake.</b></p> <p>Grass snakes are occasionally found under tins or among taller vegetation; currently the size of the population is not known. The target is to record them in at least one new</p>	<p>Grass snakes are also known as 'water snakes'. They are sensitive to vibrations and will move very quickly into cover. They swim well and are often found in water where they prey on young and adult amphibians as</p>	<p>Provide ponds with wide, vegetated margins and species-rich grassland for invertebrates, amphibians and smaller reptiles and clumps of rough grassland for basking and cover at</p>

Species and Targets	Ecological Requirements	Habitat Creation and management
<p>pond before the end of the first EMMAP.</p>	<p>well as larger invertebrates.</p> <p>They use grass piles, compost and woodchip heaps for egg-laying and incubation, in sheltered areas with direct sunshine. They hibernate underground, under log-piles or in animal holes under banks.</p> <p>They need a mosaic of generally open habitats with access to tall cover, including ponds or streams for feeding.</p>	<p>the base of all woody habitats.</p> <p>Retain all woody arisings on site in the form of brash piles, log-piles etc. or integrated into new hibernacula.</p> <p>Retain arisings from grassland management as grass heaps for egg-laying within the scrub.</p> <p>Link scrub patches to woodland and ponds via new hedgerow creation or grassy banks.</p>
<p><b>Bat assemblage.</b></p> <p>All bats need to drink, particularly in hot weather or when nursing young. Ponds will expand their available habitat (i.e., close to roosts) to provide significantly more foraging opportunity and use.</p>	<p>High numbers of flying insects on which to feed.</p> <p>Sheltered foraging areas over water, connected to commuting routes and roosts.</p>	<p>Include a wide range of locally-native aquatic plant species to maximise invertebrate diversity.</p> <p>Create areas of rough grassland and scattered scrub between the ponds and the adjacent hedgerows.</p>
<p><b>Scrub- and hedgerow-nesting birds.</b></p> <p>Target: variously 3-20 pairs or territories by completion of restoration.</p>	<p>Reed buntings require:</p> <p>Nest sites in bushes, hedgerows and patches of scrub, including bushes and tall herbs near to or over water.</p> <p>Invertebrates and seeds for feeding.</p> <p>Dense cover for winter roosts.</p>	<p>Include a wide range of locally-native aquatic plant species to maximise invertebrate diversity.</p> <p>Create areas of rough grassland and scattered scrub between the ponds and the adjacent hedgerows.</p>

---

## 7.2 RECOMMENDED PLANTING

### **Marginal and aquatic plants.**

7.2.1 Best practice advice is not to purchase nursery stock for pond planting. It is unlikely to be of local provenance, may not even be of native species (even if substitution is forbidden) and carries a high risk of importing invasive aliens. The existing ENRMF ponds have been enhanced by careful introduction of suitable native species from local sources and transplantation from these ponds will provide adequate initial stock and a source for gapping up if needed.

### **Hedgerow and scrub species.**

7.2.2 Willows (*Salix* sp.) are most suitable for use around the ponds but species used elsewhere on the Site, with the exception of blackthorn (which expands too freely), will be suitable for scattered bushes around the ponds.

### **Grassland species.**

7.2.3 The meadow mix can be planted up to the north side of the ponds and the species for which the area provides suitable conditions will survive. Between the ponds and hedgerows, a more tussocky mix could be used, including cock's-foot *Dactylis glomerata*, marsh foxtail *Alopecurus geniculatus*, tufted hair-grass *Deschampsia cespitosa* and Yorkshire-fog *Holcus lanatus*.

## 7.3 DESIGN REQUIREMENTS

7.3.1 The new amphibian ponds to be created, on the southern edge of the existing ENRMF and the northern corner of the Western Extension, should have a surface area between 100 and 300m<sup>2</sup>. The centre of the pond should be at least 1.5m deep, ideally deeper, to reduce and slow down overgrowth with bulrush *Typha latifolia*, which is widespread on the Site so it is likely its seeds will be present in the topsoil. Ponds should be unshaded by trees to the south but connected by rough grassland and scattered scrub to hedgerows for terrestrial foraging, hibernation and dispersal.

7.3.2 Soil removal or land forming to create the ponds should produce enough soil for the creation of substantial hibernacula and at least one freestanding

---

hibernaculum should be provided close to each pond (except along Swallow Brook).

## 7.4 OUTLINE PRESCRIPTIONS FOR MANAGEMENT AND AFTERCARE

### Prescriptions for pond management.

OP7.1 Monitor ponds annually during surveys and management visits for invasive native plants such as bulrush.

If small tufts of bulrush appear, pull them out by hand in winter.

OP7.2 Assess the amount of open water surface for displaying GCNs in each water body every five years.

If less than 25% of the surface is open, dredge out excess marginal plant growth in the following winter.

OP7.3 Monitor the water bodies on all visits for the presence of invasive alien aquatic plants and implement plans to remove them immediately and to prevent spread.

OP7.4 Monitor the amount and diversity of marginal and aquatic plants in all ponds during GCN surveys.

Gap-up in late summer from local sources where required to replace.

OP7.5 Monitor the water bodies on all visits for the presence of fish and if the numbers are considered to be threatening the amphibian populations, implement plans to remove them or if necessary, to drain down the pond(s) affected. ■■■

### Prescriptions for managing surrounding habitats.

OP7.6 Maintain scattered bushes between 1-3m by rotational coppicing over a ca.5-7-year cycle to provide a mosaic of heights.

OP7.7 Mow grassland between the bushes on a 2-year rotation, between October and March, to not less than 100mm.

OP7.8 Leave grassland below the canopy of each bush unmown in order to provide refuge areas for the overwintering forms of invertebrates.

---

OP7.9 Pile the arisings from mowing at intervals among the bushes to provide egg-laying sites for grass snakes and invertebrates.

**Prescriptions for monitoring.**

OP7.10 Starting from the year after the amphibian fence has been removed, lay 'tins' at intervals along the fence-line and survey for reptiles annually until occupation of this habitat is recorded, then every three years to monitor establishment and spread.

OP7.11 Once ponds are established, take them into the amphibian monitoring programme for the Site.

OP7.12 Record all signs and sightings of other target species on all management and monitoring visits.

OP7.13 Include the results from this habitat in the annual and 5-year reports.

## **8 MONITORING METHODS AND OPERATIONAL PRESCRIPTIONS**

### **8.1 RATIONALE AND AIMS**

8.1.1 Previous sections have set out requirements for habitat creation and outline prescriptions for management and aftercare of the new habitat. The rationale for monitoring is to ensure that both habitat creation and management are actually realising the aims of the EMMAP and to provide for adjusting of either if they are not. In order to achieve this:

- A suite of monitoring surveys will be carried out annually or at other intervals as set out in the plans below.
- A report, setting out the results of all surveys carried out in that year together with details of management, will be produced annually.
- Every fifth year, a review of progress against the baseline will be carried out and reported. More details of this are given in Section 8.8 below.

8.1.2 All monitoring surveys (other than the monitoring of reptiles) take as their starting point the release of restored habitats from initial aftercare and as their

aim, the measurement of progress towards the targets set out in this EMMAP or agreed following the most recent 5-year review.

- 8.1.3 Of the habitats included in this EMMAP, the targets for broad-leaved woodland, scrub and hedgerows will be met by the establishment of the planned area or length of habitat to the planting specification. No monitoring is required for these habitats, purely as habitat. The target for grassland depends on attaining and maintaining a specified plant community composition, which will depend on management and aftercare and thus must be monitored. The target for wetland habitats depends on providing ponds suitable for specified animal communities, which will also depend on maintaining plant communities so again, monitoring will be required.
- 8.1.4 Indicator species for plant communities are those given in the Northants Wildlife Sites Criteria (Northamptonshire Biodiversity Partnership, 2007, Updated 2014). Targets and Criteria for the first five years are given in Table 7 (habitats) and Table 8 (species) below.

## 8.2 SPECIES-RICH GRASSLAND

### **Operational prescriptions for monitoring of species-rich neutral grassland.**

OP8.1 Once the meadows are ready for seeding, determine and map the approximate start and end points for the route of a structured ('W') walk (EN Research Report 315, 2000).

OP8.2 Locate ██████ show on the map at least 20 recording points fairly evenly along the route (these points do not need to be marked on the ground; the method does not require the same points to be recorded each year).

OP8.3 Prepare recording sheets listing the indicator species for neutral grasslands in Northants with columns for the required number of recording points. Mark the 'strong' indicators on this list.

OP8.4 Beginning in the second year after seeding, undertake the structured walk during the peak flowering season for each meadow (June to August period). At each recording point, identify all indicator species in a half-circle of



1m radius immediately in front of the recorder. Score each species found as follows to indicate approximate abundance:

Score	% cover	Score	% cover
1	<20% (Rare)	3	40-60% (Frequent)
2	20-40% (Occasional)	4	>60% (Abundant)

On completion, sum the scores for each species and divide by the number of stops to obtain a mean score.

Throughout the walk, compile a list of all species present in the meadow.

OP8.5 Repeat the survey every third year. Report, for each meadow, the list of standard and strong indicator species recorded (together with the mean 'DAFOR' score) and the full species list.

### 8.3 WETLANDS

#### **Operational prescriptions for monitoring of aquatic wetland species.**

OP8.6 During all amphibian survey visits through the season, compile a list of all native submerged, floating and emergent species present in each pond (no abundance estimate required). Treat each pond in Swallow Brook separately and record also plants found in wet stretches of Swallow Brook between the ponds.

OP8.7 Report annually, for each group of ponds, the combined list of standard and strong indicator species recorded.

### 8.4 AMPHIBIANS

#### **Operational prescriptions for monitoring amphibian populations.**

OP8.8 Carry out a 6-visit population survey (English Nature, 2001) between March and June/July in Years 1 and 5, adjusting the timing for the species present (JNCC, 2004). Record life stage and sex of all amphibians found (where possible).

---

OP8.9 Report, for each waterbody, the presence of eggs and the number of individuals of each life stage and sex where known of each species found on each visit.

## 8.5 REPTILES

### **Operational prescriptions for monitoring reptile populations.**

OP8.10 Devise a suitable transect route for direct observation, including both currently suitable habitat (and existing refuges and basking sites) and habitat to be enhanced during aftercare. Divide the route into a number of areas and in each area, locate a set number of tins.

OP8.11 Set out the tins at the time of the first amphibian survey and check them on three further visits March-May and again in September (JNCC, 2004). Remove the tins after this visit.

OP8.12 Record the number and location of individuals of each species, with life stage and sex where known, seen by direct observation or basking on or sheltering under each group of tins in each area of the route.

OP8.13 Report, for each area, the number of individuals of each life stage and sex, where known, of each species found on each visit annually and after five years.

## 8.6 INVERTEBRATES

### **Operation prescriptions for measuring increases in invertebrate variety.**

OP8.14 Repeat baseline surveys of the northern field margin in Years 2 and 5 to compare family and species numbers.

OP8.15 Carry out a survey of the grassland and scrub areas in Years 2 and 5 to compare changes in family and species numbers.

OP8.16 Report results, including a full species list for the Site, with maps if relevant, after five years.

---

**Operational prescriptions for monitoring lepidoptera.**

OP8.17 Carry out searches for eggs, larvae and adults of the target lepidoptera in the relevant habitat on all visits in suitable weather through the season.

OP8.18 Report results, including a full species list for the Site, with maps if relevant, after five years.

**8.7 MAMMALS****Operational prescriptions for monitoring bat use of the Site habitats.**

OP8.19 Deploy 3-6 static bat detectors to record bat activity in key habitats on the current site and proposed Western Extension margins for three nights twice each year between June and August. Repeat the survey every third year.

OP8.20 Report any changes in the overall species assemblage between survey years. For each species, evaluate the +/- % change in activity between surveys, using mean/median levels of activity per species per unit of time as a proxy for the ecological value of each habitat type (note that due to high levels of inter-night variability, patterns will take time to appear and an increase or decrease in activity between consecutive survey years may be less significant than any overall trend).

OP8.21 Report the results of this survey annually and after five years.

**Operational prescriptions for monitoring dormouse colonisation of the Site habitats.**

OP8.22 Place 20 dormouse nest boxes and 25 footprint tubes in woodland edge habitat along the proposed Western Extension north-western field margin in Year 3.

OP8.23 Check footprint tubes for signs of use monthly from March to October. Check boxes for signs of dormouse (or other mammal) occupation or use in October. Remove old nests on each visit. Repeat the survey annually.

OP8.24 Report for each small mammal species using the boxes or tubes annually until the end of the current 5-year period, then review.

**Operational prescriptions for monitoring all other mammals.**

OP8.25 Record date and locations of all sightings and/or signs of use by all other mammals, including hares and signs of use, such as nests of harvest mice, during monitoring and management visits.

OP8.26 Include records of sightings and signs in the annual report and after five years.

## 8.8 BIRDS

### Operational prescriptions for bird use of the Site.

OP8.27 Record all birds using the Site for feeding, drinking, resting, roosting or breeding on every visit, together with the action recorded.

OP8.28 Compile annual lists, with activities seen, for the current ENRMF and its amphibian ponds and the proposed Western Extension, including field margins but not including birds in adjacent habitats unless they use the Site.

OP8.29 In Year 5, carry out a 3-visit Breeding Bird Survey (BBS) over the whole Site to provide a future baseline.

OP8.30 Report the full lists with activities recorded annually, with a combined total list, together with the results of the BBS after five years.

**Table 7. Initial Target Habitats and Criteria for Achieving Targets.**

Habitat and Current Area Estimate	Target	Criteria
<b>Species-rich neutral grassland.</b> Not currently present.	Establish at least 5ha of this grassland.	Neutral grassland supporting either: At least three strong indicator species or at least eight neutral grassland species.
<b>Species-rich calcareous grassland.</b>	Establish at least 3ha of this grassland (in total, over all smaller areas).	Calcareous grassland supporting either: At least six strong indicator species or at least 16 calcareous grassland species.
<b>Eutrophic wetlands, still or flowing.</b>	Observe through first EMMAP to determine	See Freshwater Habitats in Northants

Habitat and Current Area Estimate	Target	Criteria
	whether the ponds/Swallow Brook are suitable.	Biodiversity Partnership, 2007. Wildlife Sites Criteria, Northamptonshire. The Wildlife Trusts.
<b>Larval food plants for target butterflies.</b> Not currently present.	Establish at least three areas of this grassland suitable for the target butterflies.	Larval food plants for specified butterflies, as set out in prescriptions.
<b>Waterbodies.</b> Three ponds on existing ENRMF used by amphibians.	Establish at least one new pond suitable for use by amphibians and water voles.	Breeding population of one amphibian or submerged, floating or emergent indicator species present.

**Table 8. Initial Target Species and Criteria for Achieving Targets.**

Species and Current Number Estimate	Target	Criteria
<b>Amphibians.</b> GCN: medium population on existing ENRMF. Palmate newt: small population on existing ENRMF. Common toad: small population present. All three species recorded in Fineshade Woods.	Maintain populations on existing ENRMF. Aim to find at least one species on the proposed Western Extension or new ENRMF ponds over the five years.	Breeding: eggs, larvae. Presence: adults or juveniles found.
<b>Reptiles.</b> Common lizards/slow worms: present on existing ENRMF and margins of the proposed Western Extension. Grass snake: single animals occasionally found. Adder: recorded in Collyweston Great	Provide suitable habitat for all four species within the existing ENRMF or proposed Western Extension. Increase numbers of three species over the five years.	Males/females/juveniles recorded for common lizards and slow worms. Record at least two adult adders on/around proposed Western Extension.

Species and Current Number Estimate	Target	Criteria
Wood and Fineshade Woods, once from margin of Fineshade Wood.		
<p><b>Invertebrates, general.</b></p> <p>Important populations and species recorded using the margins of the proposed Western Extension, particularly the eastern edge.</p>	<p>Repeat baseline surveys of the margins and grassland in Years 2 and 5 to identify an increase in species or orders with maturing habitat.</p>	<p>Arrival of new species of grassland, scrub and wetlands, including aculeate hymenoptera and other pollinators.</p>
<p><b>Invertebrates, lepidoptera.</b></p> <p>Chequered skipper. Grizzled skipper. Dingy skipper. White-letter hairstreak. Black hairstreak. Small heath. Cinnabar moth.</p>	<p>At least four of the seven species to be recorded on new habitat by the end of the first 5-year EMMAP. At least 10 other butterfly species to be recorded on new habitat by the end of the first 5-year EMMAP. Proof of breeding by five species by the end of the EMMAP.</p>	<p>Present: recorded sightings with exact locations (photographs for target species). Eggs or larvae for breeding.</p>
<p><b>Bats.</b></p> <p>Noctule: overflies, no roost known. Soprano pipistrelle: common, commutes &amp; forages along wood edges. Barbastelle: scarcer, heard mainly along hedgerows. Brown long-eared bat: roosts and hibernation sites in Collyweston Great Wood.</p>	<p>All: identify most-used feeding areas and commuting routes; track to roosts if possible so that routes and roosts can be protected if necessary. Increase numbers by improving prey.</p>	<p>Static detector passes in all parts of the Site.</p>
<p>Brown hare: occasionally recorded on the arable.</p>	<p>Regular sightings, determine use of the woods and grassland.</p>	<p>Mapped records with times on all visits.</p>

Species and Current Number Estimate	Target	Criteria
Harvest mouse; not currently recorded.	Create suitable habitat all over the Site.	Nests located and photographed.
Dormouse: present in Fineshade Woods and known from Bedford Purlieus.	Eventual use of the proposed Western Extension and then Collyweston Great Wood.	Occupied boxes, opened hazel nuts, confirmed footprints found in tubes.
<b>Birds.</b> No list of birds for the entire site is yet available.	A list of at least 50 birds using the Site by Year 5.	Birds recorded using the current ENRMF site or proposed Western Extension habitats for feeding, resting, roosting or nesting.

## 9 REPORTING AND REVIEW

### 9.1 PRESCRIPTIONS FOR REPORTING AND REVIEW

OP9.1 Provide an annual report, setting out the results obtained in all surveys in that year, as described for each habitat or species above.

OP9.2 In every fifth year, carry out a review of both management and monitoring and extend the annual report to include, for each habitat or species/group. These recommendations will be incorporated into the phasing, landscape and restoration plan submitted under Requirement 4 of the Development Consent Order:

- An analysis of the five years' results.
- A report on progress towards the targets.
- For species, consideration of this progress in the light of UK or county trends.
- Recommendations for changes to targets where national or local trends indicate that the current target is either too low or is unlikely to be possible to meet.
- Recommendations for changes to management or additional habitat creation where national or local trends indicate that the target is reasonable but progress is not being made due to issues with the habitat.

9.1.1 The EMMAP will start on the spring equinox after fencing is removed from around the first phase, assuming planting is completed and plants are at least becoming established. If weather conditions interfere with planting or establishment, monitoring proper will be delayed for one year although aquatic surveys may commence earlier.

9.1.2 Tables 9 and 10 give the annual and seasonal work programmes for the first five years of this EMMAP. New habitats established over this EMMAP period will be taken into this programme in the first year following establishment. The instructions in Table 9 refer back to the paragraph(s) or OP(s) providing the detailed instructions. These are not repeated in Table 10 but if in doubt, check the instructions referred to in Table 9.

**Table 9. Annual Management and Monitoring Activities for the First 5-year Period.**

Year	Management	Monitoring
<b>One</b>	<p>Check the condition of the exclusion fence, trim base if necessary, repair minor damage, report major damage to site staff (OP2.6).</p> <p>Carry out refuge habitat assessments and management as necessary.</p>	<p>Carry out surveys for amphibians (OP8.8-9).</p> <p>Carry out surveys for reptiles (OP8.10-13).</p> <p>Record all mammal signs and sightings (OP8.25-26).</p> <p>Record all bird sightings (OP8.27-28).</p> <p>Provide a report of work completed (OP9.1).</p>
<b>Two</b>	<p>Carry out refuge habitat assessments and management as necessary.</p> <p>Check the condition of the exclusion fence and replace/report as necessary.</p> <p>Take into management and monitoring any new habitats created.</p>	<p>Carry out surveys for reptiles (OP8.10-13).</p> <p>Carry out a survey for commuting/foraging bats over the whole site (OP8.19-21).</p> <p>Carry out a botanical survey of the meadow grasslands, mapping clearly different areas, listing species and DAFOR. Prepare a route for a structured ('W') walk in future years (OP8.1-5).</p> <p>Record all mammal signs and sightings (OP8.25-26).</p>



Year	Management	Monitoring
		<p>Record all bird sightings (OP8.27-28).</p> <p>Carry out invertebrate surveys (OP8.14-16).</p> <p>Provide a report of work completed (OP9.1).</p>
<b>Three</b>	<p>Provide and erect 25 dormouse boxes and 25 footprint tubes (OP8.22).</p> <p>Carry out habitat assessments and management as necessary.</p> <p>Check the condition of the exclusion fence and replace/report as necessary.</p>	<p>Carry out surveys for reptiles (OP8.10-13).</p> <p>Carry out a dormouse nest box check and tube checks (OP8.22-24).</p> <p>Record all mammal signs and sightings (OP8.25-26).</p> <p>Record all bird sightings (OP8.27-28).</p> <p>Provide a report of work completed (OP9.1).</p>
<b>Four</b>	<p>Carry out habitat assessments and management as necessary.</p> <p>Check the condition of the exclusion fence and replace/report as necessary.</p>	<p>Carry out surveys for reptiles (OP8.10-13).</p> <p>Carry out a dormouse nest box check and tube checks (OP8.22-24).</p> <p>Record all mammal signs and sightings (OP8.25-26).</p> <p>Record all bird sightings (OP8.27-28).</p> <p>Provide a report of work completed (OP9.1).</p>
<b>Five</b>	<p>Carry out habitat assessments and management as necessary.</p> <p>Check the condition of the exclusion fence and replace/report as necessary.</p>	<p>Carry out surveys for amphibians (OP8.8-9).</p> <p>Carry out surveys for reptiles (OP8.10-13).</p> <p>Carry out a survey for commuting/foraging bats over the whole site (OP8.19-21).</p> <p>Carry out a botanical survey of the marginal grasslands following the structured ('W') walk (OP8.1-5).</p> <p>Carry out a dormouse nest box check and tube checks (OP8.22-24).</p> <p>Carry out breeding bird surveys of the whole site (OP8.29-30).</p> <p>Carry out invertebrate surveys (OP8.14-16).</p>

Year	Management	Monitoring
		<p>Record all mammal signs and sightings (OP8.25-26).</p> <p>Record all bird sightings (OP8.27-28).</p> <p>Provide a report of work completed and make any necessary changes and additions for the next 5-year Plan (OP9.2).</p>

**Table 10. Seasonal Management and Monitoring Activities for the First 5-year Period.**

Season	Management	Monitoring
Spring	<p>Spray the exclusion fence-line vegetation with glyphosate.</p> <p>Check the condition of the exclusion fence; trim or spray the base with glyphosate if necessary.</p> <p>Carry out minor repairs if necessary, report major damage to site staff.</p> <p>Cut grassland meadow habitats.</p>	<p>Record all vertebrates or invertebrates seen or heard.</p> <p>Set out tins for use as refugia.</p> <p>Carry out amphibian and reptile survey visits.</p>
Late spring	<p>Monitor exclusion fence-line vegetation regrowth.</p> <p>Monitor ponds for the presence of invasive plant species; remove if possible, otherwise plan action needed.</p>	<p>Carry out amphibian and reptile survey visits.</p> <p>Compile a list of all native aquatic species in each pond.</p> <p>Carry out dormouse tube checks from Year 3.</p> <p>Carry out breeding bird surveys.</p> <p>Record all vertebrates or invertebrates seen or heard.</p>
Early summer	<p>Monitor ponds for the presence of invasive plant species.</p> <p>Monitor exclusion fence-line vegetation regrowth.</p> <p>Carry out minor fence repairs if necessary, report major damage to site staff.</p>	<p>Carry out amphibian and reptile survey visits.</p> <p>Add to the list of native aquatic species in each pond.</p> <p>Carry out dormouse tube checks from Year 3.</p>

Season	Management	Monitoring
		<p>Carry out a survey for commuting/foraging bats over the whole site.</p> <p>Carry out breeding bird surveys.</p> <p>Record all vertebrates or invertebrates seen or heard.</p>
Mid-summer	<p>Monitor ponds for the presence of invasive plant species.</p> <p>Monitor exclusion fence-line vegetation regrowth.</p>	<p>Carry out amphibian and reptile survey visits.</p> <p>Add to the list of native aquatic species in each pond.</p> <p>Carry out dormouse tube checks from Year 3.</p> <p>Carry out a survey for commuting/foraging bats over the whole site.</p> <p>Carry out the structured ('W') walk in each meadow.</p> <p>Record all vertebrates or invertebrates seen or heard.</p>
Late summer	<p>Monitor ponds for the presence of invasive plant species.</p> <p>Assess the condition of woody vegetation in around ponds and in grassland margin.</p> <p>Gap-up ponds with native aquatic species if required.</p> <p>Strim grasslands around ponds if required; pile arisings for use by reptiles and invertebrates.</p> <p>Monitor exclusion fence-line vegetation regrowth.</p> <p>Cut grassland meadow habitats.</p>	<p>Complete the list of native aquatic species in each pond.</p> <p>Record all vertebrates or invertebrates seen or heard.</p> <p>Carry out dormouse tube checks from Year 3.</p>
Early autumn	<p>Strim the exclusion fence-line and/or respray vegetation with glyphosate if required.</p> <p>Carry out minor fence repairs if necessary, report major damage to site staff.</p>	<p>Carry out a reptile survey visit and remove tins.</p> <p>Carry out dormouse tube checks from Year 3.</p> <p>Record all vertebrates or invertebrates seen or heard.</p>

Season	Management	Monitoring
	Cut grassland meadow habitats.	
Late autumn	Cut grass around ponds if required; pile arisings for use by reptiles and invertebrates. Hand-pull small areas of <i>Typha</i> . Clear by hand floating and emergent pond weed to ensure 25% open water.	Check dormouse boxes for signs of occupation or use. Clear out old nests. Record all vertebrates or invertebrates seen or heard.
Early winter	Carry out scrub management and selective coppicing where needed; use woody material to make or maintain habitat piles and hibernacula.	Record all vertebrates or invertebrates seen or heard.
Mid-winter	Carry out scrub management and selective coppicing where required; use woody material to make or maintain habitat piles and hibernacula.	Record all vertebrates or invertebrates seen or heard.
Late winter	Carry out scrub management and selective coppicing where required. Use woody material to make or maintain habitat piles and hibernacula.	Record all vertebrates or invertebrates seen or heard.

## 10 REFERENCES AND BIBLIOGRAPHY

ESL, 2021 Ecological Impact Assessment: East Northants Resource Management Facility and its Western Extension, Northamptonshire:

Bat Conservation Trust. 2012. Bat surveys – Good practice guidelines, 2nd Edition. Bat Conservation Trust, London.

Beebee JC and Griffiths R. 2000. Amphibians and Reptiles. Harper Collins, London.

Bright P, Morris P A & Mitchell-Jones T. 2006. The Dormouse Conservation Handbook, 2nd Edition. English Nature, Peterborough.

---

Corbet G B and Southern H N. 1977. The Handbook of British Mammals. Blackwell Scientific Publications Ltd, Oxford.

ESL Ecological Services) Ltd. 2021. Ecological Impact Assessment: East Northants Resource Management Facility Western Extension, Northamptonshire

English Nature. 1994 (and as updated). Species Conservation Handbook. English Nature, Peterborough.

English Nature. 2000. Research Report 315: Monitoring the Condition of Lowland Grassland SSSIs. I: English Nature's Rapid Assessment Method. English Nature, Peterborough.

English Nature. 2001. Great Crested Newt Mitigation Guidelines. English Nature, Peterborough.

Herpetofauna Groups of Britain & Ireland (HGBI). 1998. Evaluating local mitigation/translocation programmes: maintaining best practice and lawful standards. Advisory notes for Amphibian and Reptile Groups. Froglife. Halesworth. Suffolk.

Joint Nature Conservation Committee. 2004. Common Standards Monitoring Guidance for Amphibians and Reptiles. JNCC, Peterborough.

Mammal Society Surveys and Monitoring available online at <http://www.mammal.org.uk/surveys>

Northamptonshire's Biodiversity Action Plan, 3rd Edition 2015-2020. Available online as a pdf at [www.northamptonshirebiodiversity.org](http://www.northamptonshirebiodiversity.org)

Northamptonshire Biodiversity Partnership. 2007. Wildlife Sites Criteria. Northamptonshire The Wildlife Trusts. Last updated 14.12.2010.

Natural Environment and Rural Communities Act, 2006. Pdf Available (Online) at [https://www.legislation.gov.uk/ukpga/2006/16/pdfs/ukpga\\_20060016\\_en.pdf](https://www.legislation.gov.uk/ukpga/2006/16/pdfs/ukpga_20060016_en.pdf)

[https://www.buglife.org.uk/resources/habitat management](https://www.buglife.org.uk/resources/habitat%20management)

**KEY**

— Red line application boundary

NOT TO SCALE

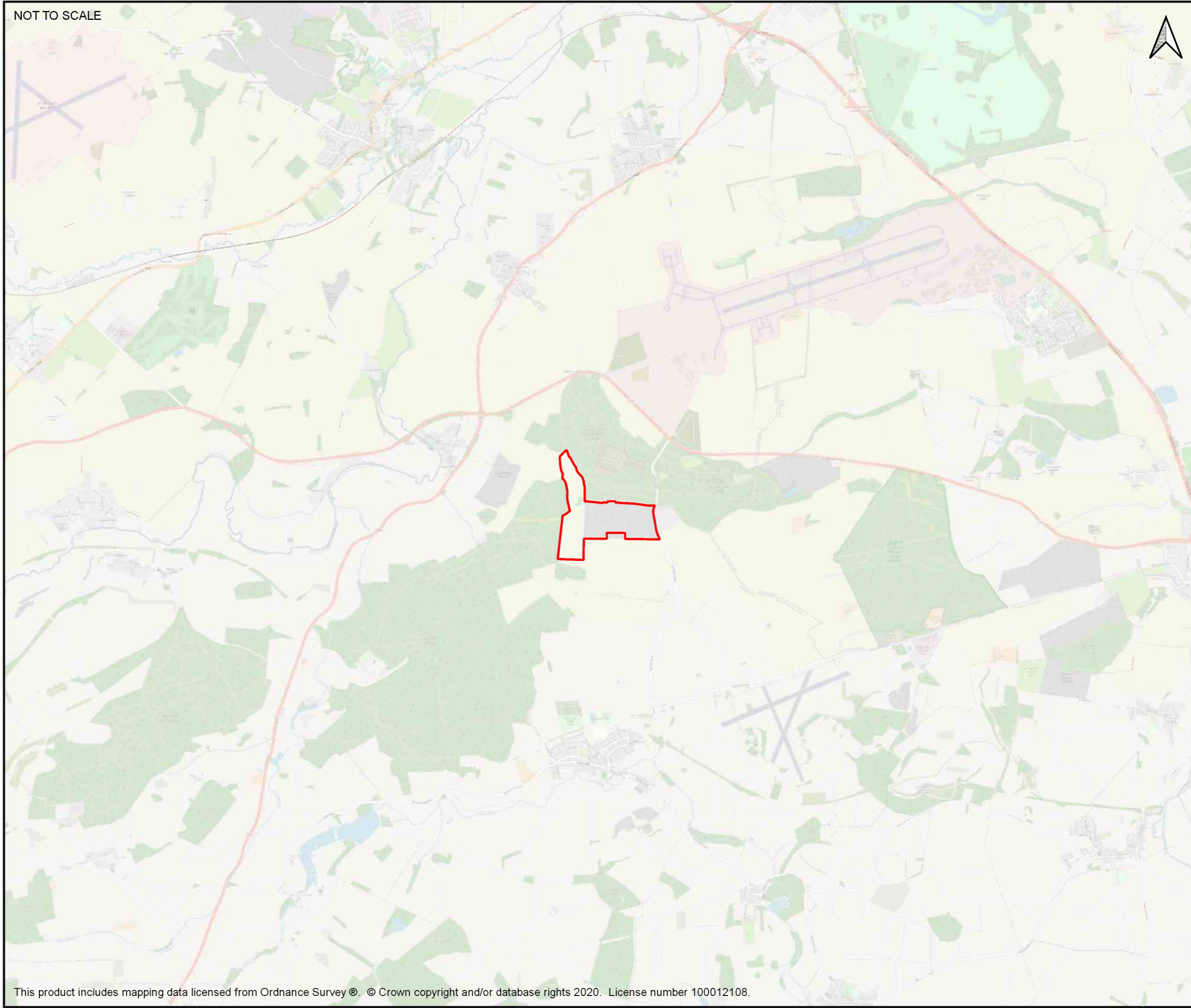





SITE NAME:  
**ENRMF Western Extension.**

DRAWING TITLE:  
**Site location.**

**Figure 1**  
Dwg no.: 118-L049-005      Date: Aug 2020



**KEY**

-  Site boundary
-  10m standoff
-  Native Species Rich Hedgerow with trees
-  Native Species Rich Hedgerow
-  Grassland enhanced for wildlife

0 100 200 m

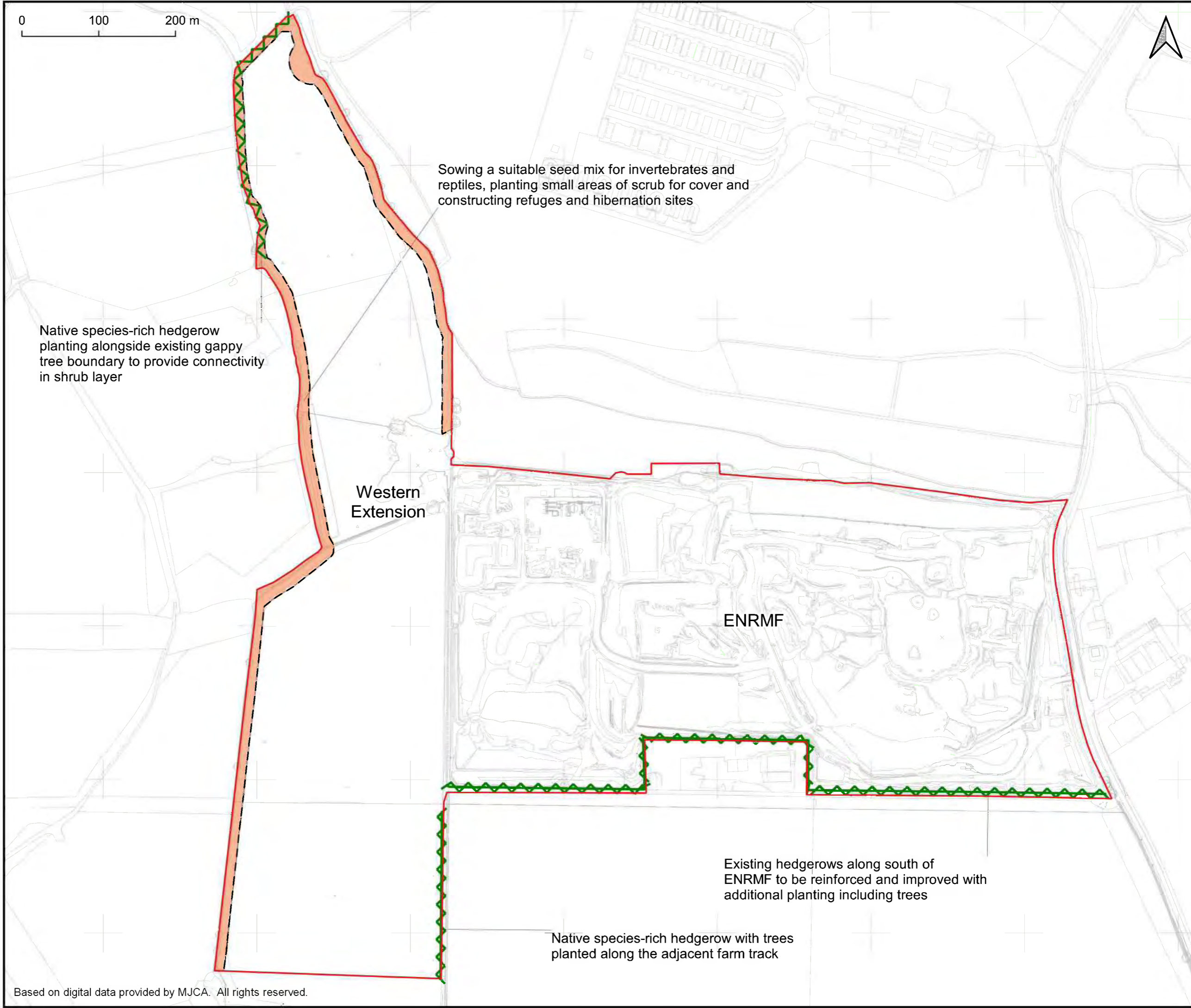

SITE NAME:  
**ENRMF Kings Cliffe.**

DRAWING TITLE:  
**Pre-construction works.**

**Figure 2**  
Dwg no.: 118-L049-035 Date: Jul 2021



Based on digital data provided by MJCA. All rights reserved.

## **APPENDIX 1**

### **TARGET SPECIES SELECTED FOR INITIAL MONITORING**





## TARGET SPECIES SELECTED FOR INITIAL MONITORING

Common name	Species name	Designation
<b>Amphibians</b>		
great crested newt	<i>Triturus cristatus</i>	HabReg-Sch2, WACA-Sch5, S41, UKBAP.
Palmate newt	<i>Lissotriton helveticus</i>	WACA-Sch5, LBAP.
Smooth newt	<i>Lissotriton vulgaris</i>	WACA-Sch5.
Common toad	<i>Bufo bufo</i>	S41, UKBAP.
Common frog	<i>Rana temporaria</i>	WACA-Sch5.
<b>Reptiles</b>		
slow-worm	<i>Anguis fragilis</i>	WACA-Sch5, S41, UKBAP.
common lizard	<i>Zootoca vivipara</i>	WACA-Sch5, S41, UKBAP.
grass snake	<i>Natrix natrix</i>	WACA-Sch5, S41, UKBAP.
adder	<i>Vipera berus</i>	WACA-Sch5, S41, UKBAP.
<b>Invertebrates</b>		
chequered skipper	<i>Carterocephalus palaemon</i>	WACA-Sch5, UKBAP.
dingy skippers	<i>Erynnis tages</i>	S41, UKBAP.
grizzled skipper	<i>Pyrgus malvae</i>	S41, UKBAP.
white-letter hairstreak	<i>Satyrium w-album</i>	WACA-Sch5, S41, UKBAP.
black hairstreak	<i>Satyrium pruni</i>	WACA-Sch5, LBAP.
small heath	<i>Coenonympha pamphilus</i>	S41, UKBAP.
cinnabar moth	<i>Tyria jacobaeae</i>	S41, UKBAP.
<b>Bats</b>		
noctule	<i>Nyctalus noctula</i>	HabReg-Sch2, WACA-Sch5, S41, UKBAP.
soprano pipistrelle	<i>Pipistrellus pygmaeus</i>	HabReg-Sch2, WACA-Sch5, S41, UKBAP.
barbastelle	<i>Barbastella barbastellus</i>	HabReg-Sch2, WACA-Sch5, S41, UKBAP.

brown long-eared bat	<i>Plecotus auritus</i>	HabReg-Sch2, WACA-Sch5, S41, UKBAP.
<b>Other mammals</b>		
brown hare	<i>Lepus europaeus</i>	S41, UKBAP.
harvest mouse	<i>Micromys minutus</i>	S41, UKBAP.
dormouse	<i>Muscardinus avellanarius</i>	HabReg-Sch2, WACA-Sch5, S41, UKBAP.



**APPENDIX DEC F**  
**SURFACE WATER MANAGEMENT PLAN**



**SURFACE WATER MANAGEMENT PLAN FOR THE  
PROPOSED EXTENDED EAST NORTANTS  
RESOURCE MANAGEMENT FACILITY**

***PINS project reference: WS010005***

**PINS document reference: 5.4.18.2**

**Report Reference: AU/KCW/JRC/20032/01SWMP  
July 2021**



**Baddesley Colliery Offices, Main Road, Baxterley, Atherstone,  
Warwickshire, CV9 2LE.**

**Telephone : 01827 717891, Fax : 01827 718507**



**CONTENTS**

1.	Introduction	1
2.	Principles of surface water management in the operational areas of the site	3
3.	Current site catchments	6
4.	Principles of the surface water management plan	10
5.	Restored site catchments and drainage constraints	14
6.	Attenuation storage	17
7.	Calculation of the capacity of the proposed ditches for the conveyance of surface water	18
8.	The maintenance and management of the surface water drainage system	21
9.	Conclusions	23
10.	References	24

**TABLES**

Table 1	Surface water catchment areas
Table 2	Upstream catchment areas

**FIGURES**

Figure 1	Documented surface water catchments (drawing reference AU/KCW/03-21/22297)
Figure 2	Topographical LiDAR data (drawing reference AU/KCW/03-21/22319)
Figure 3	Sub-catchments at and in the vicinity of the site (drawing reference AU/KCW/03-21/22354)

- Figure 4 Indicative surface water drainage ditches (drawing reference AU/KCW/05-21/22467)
- Figure 5 Restored surface water catchments (drawing reference AU/KCW/05-21/22466)

## APPENDICES

- Appendix A Surface Water Management Plan dated May 2007
- Appendix B Topographical survey of the proposed western extension
- Appendix C Proposed restoration concept scheme
- Appendix D Greenfield runoff calculations
- Appendix E Attenuation storage calculations
- Appendix F Drainage ditch calculations

---

This report has been prepared by MJCA with all reasonable skill, care and diligence, and taking account of the Services and the Terms agreed between MJCA and the Client. This report is confidential to the client and MJCA accepts no responsibility whatsoever to third parties to whom this report, or any part thereof, is made known, unless formally agreed by MJCA beforehand. Any such party relies upon the report at their own risk.

## 1. Introduction

- 1.1** MJCA is commissioned by Augean South Limited (Augean) to prepare a Surface Water Management Plan for the restored East Northants Resource Management Facility (ENRMF) to include the proposed western extension to the site. The western extension to the site and alterations to the existing ENRMF are the subject of an application for a Development Consent Order (DCO) with PINS project reference WS010005. This Surface Water Management Plan comprises an update to the current approved surface water management plan for the site dated May 2007 (2007 SWMP). A copy of the 2007 SWMP is provided at Appendix A to this report. This Surface Water Management Plan (2021 SWMP) has been prepared in support of the application for the DCO. The purpose of the 2021 SWMP is to demonstrate that surface water can be managed as part of the restored site such that there is no significant change in drainage or increase in flood risk downstream of the site.
- 1.2** Operational surface water management is regulated by the Environment Agency through Environmental Permit reference EPR TP3430GW for the site. The principles of the operational surface water management are presented in this surface water management plan.
- 1.3** The 2021 SWMP is based on the agreed 2007 SWMP and relies on information presented in the 2007 SWMP hence no amendments to the calculations or design works presented in the 2007 SWMP have been carried out as part of this surface water management plan. Consistent with guidance calculations have been carried out to demonstrate that surface water runoff from a 1 in 100 year rainfall event with an allowance for climate change can be managed on site with discharge at the pre-development greenfield runoff rate or 2l/s/ha whichever is greater or at the permitted discharge rate.
- 1.4** Schematic plans of the proposed surface water drainage ditchcourses are presented in this report. The principles for the detailed designs of the ditchcourses presented in the 2007 SWMP will be used when the final designs

are prepared prior to restoration of each phase of the site. It is concluded that surface water runoff from a 1 in 100 year rainfall event with an allowance for climate change can be managed on site. It is anticipated that the precise locations of the ditches and surface water attenuation basins or detention basins presented in this report may change following further investigations in the central area of the site where a proposed ditchcourse will convey water from west to east across the site to discharge into a swallow hole consistent with current routes of surface water flow. Any changes will be subject to final design and approval from the relevant planning authority as part of the final detailed designs prepared prior to restoration of each phase of the site.



## 2. Principles of surface water management in the operational areas of the site

2.1 As there will be continuity of operation between the existing ENRMF site and the proposed western extension area the scheme for managing surface water during the operational period in the western extension is based generally on the current surface water management practices at the site. The management of surface water in the operational areas of the site is the subject of specific Augean site management procedures implemented through Augean's Environmental Management Systems and regulated by the Environment Agency through the Environmental Permit. The general principles of the operational surface water management procedures are explained in this report.

2.2 Surface water runoff from the restored areas in the existing ENRMF site is managed by a system of drains and ponds broadly in accordance with the existing 2007 SWMP. Part of the current surface water management systems on the site comprises a series of drainage channels (cut off ditches) which are located across the landfill and round the site boundary generally. The water from the channels discharges to a series of ponds which are located strategically at points near the boundary to manage flow.

2.3 The status of each area on the site changes over time as the site operations progress, for the purposes of operational surface water management the operational site at any given time is spilt into the following conceptual catchment areas and surface water management systems:

- **Excavation and landfill cell construction areas** - Incident rainfall and runoff to these areas either infiltrates into the ground, evaporates, or is contained within the excavation which is then dewatered to allow the cell construction works to progress.
- **Operational landfill cells** - Incident rainfall and runoff to these areas is collected in the cell and absorbed into the waste mass and becomes part of the waste and leachate within the cell.

- **Uncapped or uncovered areas of completed cells with waste exposed at the surface** - These areas are limited to the small area of the most recently completed landfill cell and rainfall and runoff is managed as for operational landfill cells. Given the availability of site derived low permeability clays these areas are temporarily capped quickly with capping and restoration to follow.
- **Capped and restored areas, including temporarily capped and areas with clean stockpiled materials (site derived overburden and clays)** - Once temporarily capped, or capped and restored, a ditch system is developed following the principles of the 2007 SWMP to allow the separate collection of clean surface water runoff so that it can be directed to clean surface water ponds for discharge from site. These areas continue to change due to stockpiling needs and the principles of the 2007 SWMP are progressively implemented. The ongoing development of the site will allow further capped and restored areas to be completed and allow connection of the surface water systems to the permitted discharge point in the south east of the site.
- **Soil treatment plant (STP)** - The STP comprises a sealed surface area. Specific design calculations for the STP show that the storage volume in the tanks and on the soil processing pad area is capable of providing sufficient surface water storage for a 1 in 100 year event. The surface water runoff control procedures and requirements of the STP are monitored and reviewed and where necessary updated to reflect future changes. The site development assumes that in the operational life of the site the STP will be removed and the area will be excavated and developed as a landfill cell and then restored following the principles of the 2007 SWMP.
- **Dredging waste lagoon** - Incident rainfall and runoff to this area is collected within the dredging waste lagoon and the collected water is used in the STP processes. The site development assumes that in the operational life of the site the dredging waste lagoon will be removed and the area excavated and developed as a landfill cell and then restored following the principles of the 2007 SWMP.
- **Haul roads** - Incident rainfall and runoff to the haul roads is collected within the ditches constructed adjacent to the haul roads and directed to dedicated

surface water lagoons or collection points. Given the potential for waste residues to accumulate on the haul roads, the collection of surface water runoff from the haul roads within the same ditches, lagoons and ponds as clean water is avoided. Potentially 'dirty' water runoff from haul roads is used in dust suppression, in wheel washes and managed through the STP surface water system.

- **Ditches and ponds** – The ditch and pond system is being developed as areas of the site are restored following the principles of the 2007 SWMP to allow the separate collection of clean surface water runoff so that it can be directed to clean surface water ponds or discharged from site.

**2.4** In summary the collection of clean water runoff from capped and restored areas is separate from the collection of runoff from haul roads comprising potentially contaminated water. The generation of potentially contaminated water is reduced by constructing separate bunded ditches along haul roads with separate dedicated clean and potentially polluted surface water collection lagoons.

**2.5** The principles of the operational surface water management procedures will continue in the proposed western extension with the installation of a system of drains and attenuation basins following the principles of the 2007 SWMP and the restoration proposals presented in this report.

### 3. Current site catchments

- 3.1** The hydrology at and in the vicinity of the site is described in detail in the Environmental Statement submitted in support of the DCO application. The site is located in the catchment of the River Nene which flows generally eastwards and is located approximately 6km east south east of the existing ENRMF site at the closest point.
- 3.2** Information on the surface water catchments at the site on the Environment Agency catchment data explorer website indicates that the proposed western extension is partially within the catchment of the Wittering Brook and is partially within the catchment of the Willow Brook consistent with the existing ENRMF site. The catchments of the Wittering Brook and the Willow Brook are shown on Figure 1.
- 3.3** A drainage ditch runs along the western and southern boundaries of Collyweston Great Wood to the east of the proposed western extension and north of the existing ENRMF site. It is understood that the drainage ditch continues eastwards from the site joining a tributary of the Wittering Brook where it issues approximately 2.0km north east of the existing ENRMF site. The Wittering Brook joins the River Nene approximately 7.5km east of the existing ENRMF site.
- 3.4** The ditch to which site runoff is discharged via the permitted discharge point in the south east of the existing ENRMF site flows generally to the south and joins a drainage ditch running west to east on the west side of Stamford Road approximately 450m south south east of the existing ENRMF site. The west to east drainage ditch runs along the northern boundary of Little Wood approximately 50m south of the western extension and continues eastwards to the east of Stamford Road and then south eastwards to where it joins a tributary of Willow Brook. The tributary outfalls to the Willow Brook approximately 2.5km south of the existing ENRMF site. The Willow Brook joins the River Nene approximately 9km south east of the existing ENRMF site.

### Permitted ENRMF site

- 3.5** The existing ENRMF site comprises a northern and a southern catchment area. The details of the catchment areas and the currently approved surface water management scheme for these areas is presented in the 2007 SWMP (Appendix A).

### Proposed western extension

- 3.6** Consistent with the existing ENRMF site, the proposed western extension is on a surface water divide. The north eastern half of the northern area of the proposed western extension drains to the east to the drainage ditch which runs along the western and southern boundaries of Collyweston Great Wood eventually joining a tributary of the Wittering Brook. The remainder of the northern section and the central area of the proposed western extension to the landfill drains via field drains and drainage ditches to a swallow hole located approximately 10m to the north of the north western corner of the existing ENRMF site boundary. Surface water entering the swallow hole at the site enters groundwater beneath the site which it is likely feeds tributaries of the Willow Brook and the Willow Brook to the south. The southern section of the proposed western extension area drains to the south and south east to the drainage ditch that runs from west to east approximately 50m south of the site and continues eastwards to the east of Stamford Road and then south eastwards to where it joins a tributary of Willow Brook.
- 3.7** The current catchments at the site have been determined from the available Light Detection and Ranging (LIDAR) data at and in the vicinity of the site from the Environment Agency National LIDAR Programme digital terrain model (DTM). The topography at and in the vicinity of the site comprising the available LIDAR data are shown on Figure 2. A topographical survey of the proposed western extension is presented at Appendix B. The LIDAR data is consistent with the topographical survey of the site as can be seen from a comparison of the survey (Appendix B) and the LIDAR data (Figure 2). The site catchments have been delineated based on the LIDAR data and the

catchments are presented on Figure 3. The approximate areas of the pre-development catchment areas across the western extension are presented in Table 1.

### **Surface water entering the site from upstream**

- 3.8** A number of drainage ditches from land to the west of the extension area drain into the perimeter drainage ditches round the proposed western extension area with a drainage ditch from the south culverted under the central part of the extension area towards the swallow hole. A second culvert approximately 175m north of the southern culvert is located under the central part of the extension area draining from the west towards the swallow hole. The entrance to the southern culvert was partially filled with soil debris during a site visit in June 2021 with the exit in the southern valley feature near the swallow hole buried. Surface water from the perimeter ditch was observed entering a clay pipe close to the culvert entrance. The pipe was orientated along the boundary between the northern and southern part of the proposed western extension. The outfall of the pipe could not be located. It is known that drainage along this boundary is routed to flow towards the swallow hole entering the swallow hole from the south.
- 3.9** Based on the available LIDAR data for topography to the west of the site, areas to the north west of the site drain towards the northern part of the northern area of the site and towards the south of the northern area as well as to the central area of the site. Areas to the south west of the site drain towards the central area of the site. There are areas to the north west, west and south west of the site that drain towards depressions located to the west of the central area of the site. Based on observations made during site visits in February and June 2021 these comprise dolines with water draining into the depressions infiltrating the ground in the base of the depressions. At the time of the site visits there was little evidence of surface water flowing from these depressions onto the site or entering the culverts under the central part of the extension area.

- 3.10** A small area to the west of the south western corner of the site will drain to the southern area of the site. The upstream catchments in the vicinity of the site are shown on Figure 3.
- 3.11** The approximate areas of the upstream catchments draining to the western extension are presented in Table 2.

### **Flood risk**

- 3.12** Flood risk at and in the vicinity of the site is described in detail in the Environmental Statement submitted in support of the DCO application. The site is located in Flood Zone 1 comprising land having a less than 1 in 1,000 annual probability of river or sea flooding. Hazardous waste landfill sites comprise '*more vulnerable development*' as defined in the National Planning Policy Framework (NPPF) technical guidance on flood risk (reference 1) and they are considered appropriate development in Flood Zone 1. The flood risk maps show that the majority of the site is shown as at very low to low risk of flooding from surface water with limited areas of medium to high risk in the central area of the proposed western extension at the extremities of the culverts and in the vicinity of the swallow hole.

#### **4. Principles of the surface water management plan**

- 4.1** The Wittering Brook and the tributary of the Willow Brook to which the drainage ditches collecting runoff from the site discharge are ordinary watercourses. Lead local flood authorities, district councils and internal drainage boards carry out flood risk management work on ordinary watercourses. North Northamptonshire Council is the Lead local Flood Authority (LLFA) for the ordinary watercourses in the vicinity of the site and is a statutory consultee to the planning process to assess the surface water drainage implications of proposed developments.
- 4.2** LLFA guidance (reference 2 and 3), Department for Environment, Food and Rural Affairs (DEFRA), Sustainable Drainage Systems guidance (reference 4) and Industry Code of Practice guidance on surface water management systems at landfill sites (reference 5) has been used together with guidance presented on the Environment Agency website (reference 6) and included in the technical guidance to the NPPF in respect of flood risk (reference 1) to inform the 2021 SWMP.
- 4.3** The proposed restoration concept scheme for the whole of the ENRMF site including the existing ENRMF site and the proposed western extension area is presented on the plan presented at Appendix C. The restoration topographic contours together with the indicative surface water features that will be present at the site following restoration are shown on Figure 4. The proposed restoration does not include any areas of hardstanding and comprises a domed restoration profile compared with the relatively flat pre-development topography. Soil stripped during excavations at the site will be retained on site and used in the restoration. The restoration soils will comprise clay loam and clay soils.
- 4.4** The 2021 SWMP is based on sustainable drainage principles consistent with guidance. Sustainable drainage systems typically control runoff rates and volumes hence reduce the risk of downstream flooding, encourage infiltration rather than direct conveyance of surface water where possible, reduce



concentrations of suspended solids in runoff and where possible provide habitat for wildlife and enhanced aesthetic and amenity value. As the surface water management plan has been developed to be consistent with the principles of sustainable drainage the components of the scheme form part of a system of integrated water management features which will contribute to the sustainable management of surface water at the restored ENRMF by controlling runoff as close to the source where feasible and managing water on a site wide basis taking into consideration the potential for impacts on surface water flows and quality locally and in the wider hydrological environment.

**4.5** The design principles on which the 2021 SWMP is based are summarised below:

- A series of surface water attenuation basins or detention basins will be created in the restored areas of the site.
- Shallow ditches will direct runoff to the basins and ditches will convey water between the basins and the point of discharge from the site where discharge is not directly from the basins.
- The rate at which water can leave each attenuation basin will be controlled so that during extreme rainfall events a proportion of runoff will be held back to attenuate the runoff peak.
- The function of the basins is for surface water attenuation only. Should the basins be developed such that water is maintained in the basins for other purposes such as ecology a freeboard will be maintained to accommodate the necessary surface water attenuation.
- The current outlet for the discharge of water from the surface water management system will be maintained so that water can drain by gravity and in a controlled manner to the permitted discharge point at the southern east corner of the existing ENRMF site. Suitable outlets for the discharge

of water from the surface water management system will be created so that water can drain by gravity and in a controlled manner to the swallow hole, to the eastern drainage ditch round Collyweston Great Wood which joins a tributary of the Wittering Brook and to the southern drainage ditch which joins a tributary of the Willow Brook.

- The rate at which water will leave the surface water management system will be constrained to a rate equivalent to the greenfield runoff rate or 2l/s/ha, whichever is larger, consistent with guidance so the risk of flooding downstream is minimised.
- The design rainfall event assumed for the purpose of the calculations presented in this report is the 1 in 30 year rainfall event plus a 20% allowance for climate change. The 20% central allowance for climate change is the potential increase in peak rainfall intensity specified in Environment Agency guidance for design allowances (reference 6) resulting from anticipated climate change during the period 2085 to 2115. The extreme rainfall event assumed for the purpose of the calculations presented in this report is the 1 in 100 year rainfall event plus a 40% allowance for climate change. The 40% upper end allowance for climate change is the potential increase in peak rainfall intensity specified in Environment Agency guidance for design allowances (reference 6) resulting from anticipated climate change during the period 2085 to 2115.
- A portion of the surface water discharge from the restored landform will be routed to the swallow hole consistent with pre-development conditions at the site. It is assumed that further infiltration based approaches for surface water attenuation in other areas of the site generally will not be appropriate following restoration due to the significant thickness of low permeability strata above the underlying aquifer.

**4.6** Further information on the parameters and assumptions affecting the operation of the surface water management system are presented in Section 5. The results of calculations to estimate the attenuation capacities necessary

in the individual basins is presented in Section 6. The results of calculations of the dimensions of perimeter ditches which will need to convey water from discharge points from the detention basins to the west to east crossing are presented in Section 7.

## 5. Restored site catchments and drainage constraints

5.1 The proposed restored site has been divided into seven catchments delineated based on the topographic restoration contours and the surface water drainage ditches draining the restored land to basins at the low point in each catchment as shown on Figure 4. The seven catchments are shown on Figure 5. The point of discharge of each of the seven catchments is summarised in the table below. The approximate areas of the catchments are presented in Table 1.

Catchments	
Catchment 1	Drains to basin C1 in the south east discharging to the permitted discharge point
Catchment 2	Drains to basin C2 in the north west of the existing ENRMF site discharging to the swallow hole
Catchment 3	Drains to basin C3 in the west discharging to the western drainage ditch which in turn discharges to the swallow hole via the west to east crossing
Catchment 4	Drains to basin C4 in the west discharging to the western drainage ditch which in turn discharges to the swallow hole via the west to east crossing
Catchment 5	Drains to basin C5 in the south west discharging to the drainage ditch to the south of the site
Catchment 6	Drains to basin C6 in the north discharging to the drainage ditch to the east of the site
Catchment 7	Drains to basin C7 in the west discharging to the swallow hole via the west to east crossing

5.2 The design of the proposed ditchcourse which will convey water from west to east across the proposed western extension to discharge into the swallow hole at the north western corner of the existing ENRMF site will be the subject of the results of further investigation. The ditchcourse will be constructed and will be designed to convey flows at the greenfield runoff rate for a 1 in 100 year event with an allowance for climate change as a minimum. The detail of the watercourse design will be agreed with the relevant planning authority following confirmation of the design of the crossing from the results of further investigation.

### **Pre-development greenfield runoff rates**

- 5.3** The indicative surface water catchment of the site including areas which are external to the site and which may drain to the site has been delineated based on available topographical information as presented in Section 3. Calculations to determine the current greenfield surface water runoff rate from the catchments in the western extension have been carried out using the method presented in The Institute of Hydrology (IOH) document entitled “Flood estimation for small catchments” report number 124 dated 1994 (reference 7, the IOH 124 method). Consistent with guidance the Flood Estimation Handbook (FEH) rainfall intensity data has been used in the calculations. The greenfield surface water runoff rate for the mean annual flood (Qbar) has been calculated with a growth factor applied to calculated the 1 in 30year and the 1 in 100year greenfield runoff rates. The calculations are presented at Appendix D. The greenfield run off rates for the existing ENRMF are presented in the 2007 SWMP.
- 5.4** The calculated Qbar using the IOH 124 method are all less than 2l/s/ha. For the purpose of the calculations a discharge limit of 2l/s/ha is assumed. Qbar calculations using the FEH statistical method have been carried out using the UKSUDS online tool for comparison with the IOH 124 results and the 2l/s/ha limit assumed. A HOST class number of 22 (Till, compacted head) has been selected for the site in the calculations. The results of the IOH 124 method and the FEH statistical method for the Qbar calculations using the UKSUDS online tool are presented at Appendix D together with a summary table of the results (Table D4). The 2l/s/ha limit has been selected as a conservative assumption given the known limitations of both the IOH 124 method and the FEH statistical method in respect of small catchments.

### **Permitted discharge**

- 5.5** The permitted discharge from the site is an outfall from the south east pond (2007 SWMP) comprising a 225mm diameter pipe which discharges to the upstream point of a road culvert. It is calculated in the 2007 SWMP that with

no orifice control an outflow rate from the site for the critical 1 in 100 year return period storm would be approximately 110l/s. It is calculated in the 2007 SWMP that the downstream highway culvert would have the capacity to receive a discharge rate of over 500l/s from the site without being at risk of flooding. This is significantly greater than the 1 in 100 year return period storm outflow rate with no orifice control reported in the 2007 SWMP with a 40% upper end allowance for climate change of approximately 150l/s. The design of the permitted discharge point in the 2007 SWMP is such that the permitted discharge rate from the site is 50l/s.

### **Comparison of pre-development and restored catchments**

- 5.6** As can be seen from the comparison in Table 1 similar areas of the pre-development catchments and restored catchments discharge to the permitted discharge point, the eastern ditch, the swallow hole and the southern ditch.

## 6. Attenuation storage

- 6.1** The discharges from the restored catchment areas will be controlled at the pre-development greenfield runoff rates or at 2l/s/ha, whichever is larger, consistent with guidance or at the permitted discharge rates such that there will be no increased flood risk downstream of the site as a result of the proposed development. The basins at the low point in each of the restored site catchments have been sized such that the capacity of the basins can store the amount of water it is necessary to attenuate so that the discharge from the basins is managed to the pre-development discharge rates or at the permitted discharge rate. Consistent with guidance FEH rainfall intensity data has been used in the calculations. Calculations to estimate the attenuation storage that will be created as a result of the construction of the attenuation basins as part of the restoration are presented at Appendix E.
- 6.2** The detention basins have been sized to accommodate the calculated 1 in 30 year return period storm with a 20% allowance for climate change with an additional 300mm freeboard based on the permitted discharge rate from catchment 1 and the 2l/s/ha discharge rate from all other catchments. The indicative capacity of the detention basins are presented on Figure 5. The detail of the detention basins in each area will be designed and agreed with the relevant planning authority before the development of each phase of the landfill. The calculated maximum attenuation storage needed in each catchment for a 1 in 100 year return period storm with a 40% allowance for climate change is presented in Table E15 at Appendix E. It is proposed that low bunding is formed round the attenuation basins such that the additional attenuation storage needed for the 1 in 100 year return period storm with a 40% allowance for climate change can be accommodated. The indicative bund round attenuation basin C1 is shown on Figure 5. The indicative height of the perimeter bunds needed round the attenuation basins is presented in Table E15 at Appendix E.

## 7. Calculation of the capacity of the proposed ditches for the conveyance of surface water

7.1 Consistent with the 2007 SWMP surface water ditches will be excavated into the restoration soils of the landfill to direct runoff to the attenuation basins with the indicative ditch section profile presented on Drawing 1621.SWM.10 of the 2007 SWMP (Appendix A). Intermediate ditches will be provided on the batter slopes to intercept and slow the rate of run off to reduce ravelling and the risk of erosion of the restoration soils and underlying cap.

7.2 It is proposed that surface water from detention basin C1 will discharge to the permitted discharge location in the south east of the site at the permitted discharge rate. It is proposed that surface water from detention basin C2 will discharge to the swallow hole at the 2l/s/ha discharge rate. It is proposed that surface water from detention basins C3 and C4 will discharge to the perimeter ditch at the 2l/s/ha discharge rate. Water in the perimeter ditch will convey water northwards to the west to east crossing in the central area of the site where it will eventually discharge to the swallow hole. It is proposed that surface water from detention basin C5 will discharge to the perimeter ditch at the 2l/s/ha discharge rate. Water in the perimeter ditch will convey water southwards and will discharge to the drainage ditch to the south of the site. It is proposed that surface water from detention basin C6 will discharge from the site to the drainage ditch along the eastern boundary of the western extension at the 2l/s/ha discharge rate. It is proposed that surface water from detention basin C7 will discharge at the 2l/s/ha discharge rate to the west to east crossing in the central area of the site where it will discharge to the swallow hole. The discharge from each of the catchment areas will be controlled in a similar manner to that set out in the 2007 SWMP with suitable flow control apparatus such as discharge pipes of an appropriate diameter at the outlet from the attenuation basins such that the rate at which water leaves the basins does not exceed the flow rate assumed in the calculations.



- 7.3** The western perimeter ditch which currently conveys water from off site to the southern culvert across the central area of the proposed extension and then to the swallow hole will also convey water from catchments 3 and 4 following restoration to the proposed watercourse crossing the site from west to east to discharge to the swallow hole. Prior to any development at the site these areas of the site drained directly to the area of the swallow hole from the site via field drains or drainage ditches internal to the existing ENRMF site as well as the western extension site. The western perimeter ditch which conveys water from off site to the southern drainage ditch will also convey water from catchment 5 following restoration to the southern drainage ditch. Pre-development these areas of the site drain directly to the southern drainage ditch from the site via field drains. Indicative calculations of the capacity of the western perimeter ditch to convey water to the west to east crossing and to the southern drainage ditch are presented at Appendix F and are described in this section. All other perimeter drainage ditches will convey water from similar drainage routes and at similar rates pre and post development.
- 7.4** The capacity of a drain to convey surface water has been calculated based on Manning's resistance equation which takes into account the dimensions, geometry and other characteristics of the drain. For the purposes of the calculations it is assumed that the drain will comprise an open ditch generally. Calculations of the flow capacity in the drain using Manning's resistance equations are presented in Table F1 at Appendix F. The calculation of the relevant Manning's roughness coefficient is presented in Table F2 at Appendix F.
- 7.5** Based on the calculations presented at Appendix F the perimeter ditch will have a flow capacity sufficient to convey the necessary quantity of surface water during the 1 in 100 year rainfall event plus a 40% allowance for climate change to the west to east crossing and to convey the necessary quantity of surface water during the 1 in 100 year rainfall event plus a 40% allowance for climate change to the southern drainage ditch. Suitable flow control apparatus will be constructed at the outlets from the detention basins in the restored

catchment areas such that the rate at which water enters the receiving drainage ditches from the site during the design storm event does not exceed the flow rates assumed in the calculations. It is anticipated that the locations of the ditches and surface water attenuation basins or detention basins may be refined following further investigations in the central area of the site where a proposed watercourse will convey water from west to east across the site to discharge into the swallow hole consistent with current routes of surface water flow.

- 7.6** The western perimeter drain discharges to a culvert beneath the southern track thence into the southern drain. The culvert comprises a 200mm diameter plastic pipe. Making assumptions about the fall of the pipe across the track based on the topographical survey and observations during a surface water features survey of the site in October 2019, the pipe has the capacity to convey at least twice the necessary quantity of surface water during the 1 in 100 year rainfall event plus a 40% allowance for climate change.

## **8. The maintenance and management of the surface water drainage system**

**8.1** Consistent with the LLFA guidance the drainage system in the restored areas shall be subject to regular maintenance to secure its efficient operation and the effective management of water.

**8.2** During the operational period of the site including restoration operations Augean will maintain and manage the drainage system in the areas of the site where the operations being carried out affect the drainage system. In the parts of the extension area where landfill development has not yet commenced and where agricultural activities continue the responsibility for maintenance and management of the surface water drainage system will remain with the farmer until the landfill development commences and normal agricultural activities no longer are practicable.

**8.3** Following restoration an agreed aftercare scheme will be in place which will include the maintenance and management of the surface water drainage system for an agreed period.

**8.4** The principles on which maintenance and management will be based are set out below:

- Regular inspections of the surface water drainage system will be undertaken. The purpose of the inspections will be to confirm the adequate performance of the drainage system, to identify operational problems and to facilitate planning of maintenance actions as necessary.
- Insofar as it is practicable inspections of the surface water drainage system will be carried out in a range of weather conditions including during rainfall events.
- Maintenance actions will be planned and implemented as necessary to facilitate the proper functioning of the drainage system.

- The planning and implementation of maintenance actions will take into account the protection of habitats and ecosystems as necessary.

**8.5** Specific maintenance and management actions are likely to include but may not be limited to:

- Removal of litter and debris from attenuation basins and ditches at the site as necessary.
- Sediment management such as the removal of accumulated sediment in attenuation basins and the ditches as necessary.
- Inspection and remedial maintenance of the flow control structures at the outlet of attenuation basins as necessary.
- Grass cutting and other vegetation management such as pruning as necessary.
- Control of weeds and invasive plants as necessary.
- Repairing damage to ditches caused by erosion or other processes.

Management in support of the wider nature conservation objectives of the restored site are included in the ecological assessments presented in the Environmental Statement and associated schemes submitted in support of the DCO application.

**8.6** The management regime will be updated as necessary as the operations and restoration works the subject of the approved aftercare scheme progress.

## 9. Conclusions

- 9.1** The post restoration 2021 SWMP is designed based on the principle that there will be no significant increase in surface water discharges from the site compared with the pre-development situation, hence no increased flood risk downstream of the site following restoration including during a 1 in 100 year rainfall event when a potential 40% increase in rainfall intensity as a result of climate change is taken into account.
- 9.2** The proposed restoration design incorporates areas designed to function as attenuation basins. The rate at which water will leave the attenuation basins will be controlled so that during extreme rainfall events a significant proportion of runoff will be retained to attenuate the runoff peak. On this basis the surface water attenuation function of the 2021 SWMP will be accomplished primarily by allowing water to accumulate in the basin areas temporarily during storm events and to be released from the basin areas in a controlled manner.
- 9.3** It is demonstrated in the 2021 SWMP that surface water can be managed on site without increased flood risk downstream of the site. The final details of the design of the drainage ditches and associated surface water attenuation basins will be agreed with the relevant planning authority prior to development of each landfill area.
- 9.4** The management and maintenance of the 2021 SWMP and the plan's capacity to facilitate water quality improvements is generally consistent with the existing surface water management plan.

## 10. References

1. <https://www.gov.uk/guidance/flood-risk-and-coastal-change>
2. Northamptonshire Lead Local Flood Authority. 2017. Local Standards and Guidance for Surface Water Drainage in Northamptonshire. Version 1.3 dated August 2016 and updated in September 2017
3. East Northamptonshire Council. 2020. Strategic Flood Risk Assessment (SFRA) Level 1. Review and update of 2011 Level 1 SFRA. FINAL SFRA update February 2020.
4. Department for Environment, Food and Rural Affairs. 2015. Sustainable Drainage Systems. Non-statutory technical standards for sustainable drainage systems. Dated March 2015.
5. Landfill Guidance Group Industry Code of Practice no. LGG 116. 2018. Sizing of surface water management systems at landfill sites. Dated February 2018.
6. <https://www.gov.uk/guidance/flood-risk-assessments-climate-change-allowances#types-of-allowances> and <https://www.gov.uk/guidance/flood-and-coastal-risk-projects-schemes-and-strategies-climate-change-allowances#peak-rainfall-intensity-allowances> accessed in April 2021
7. The Institute of Hydrology. 1994. Flood estimation for small catchments. Report number 124 dated 1994.
8. Flood Estimation Handbook Web Service <https://fehweb.ceh.ac.uk/GB/map>
9. National Coal Board. 1982. Technical management of water in the coal mining industry.
10. Highways Agency. February 2004. Drainage of runoff from natural catchments. Design manual for roads and bridges, Volume 4, Section 2, Part 1. Report reference HA 106/04

11. United States Geological Survey. 1989. Guide for Selecting Manning's Roughness Coefficients for Natural Catchments and Floodplains. United States Geological Survey Water-Supply Paper 2339.

**TABLES**



Table 1

## Surface water catchment areas

Catchment	Area draining to eastern drainage ditch <sup>1</sup> (m <sup>2</sup> )	Area draining to the swallow hole (m <sup>2</sup> )	Area draining to southern drainage ditch <sup>2</sup> (m <sup>2</sup> )	Area draining to permitted discharge point (m <sup>2</sup> )
<b>Predevelopment catchment</b>				
<b>Western extension</b>				
North and eastern margin of the northern area	49,650			
South and western margin of the northern area and the central area		155,100		
Southern area			64,100	
<b>Permitted ENRMF<sup>3</sup></b>				
Northern catchment		67,000		
Southern catchment				257,200
<b>TOTAL</b>	<b>49,650</b>	<b>222,100</b>	<b>64,100</b>	<b>257,200</b>
<b>Restored site</b>				
Catchment 1				201,970
Catchment 2		60,945		
Catchment 3		82,230		
Catchment 4		27,750		
Catchment 5			59,080	
Catchment 6	41,075			
Catchment 7		32,930		
Additional areas <sup>4</sup>	3,400	42,715	3,035	24,180
<b>TOTAL</b>	<b>44,475</b>	<b>249,055</b>	<b>62,115</b>	<b>226,150</b>

1 Eastern drainage ditch round Collyweston Great Wood draining eastwards joining a tributary of the Wittering Brook.

2 Southern drainage ditch draining eastwards and then south eastwards joining a tributary of Willow Brook

3 Permitted ENRMF areas are taken from 2007 SWMP giving a total area of the existing ENRMF site of 324,200m<sup>2</sup>. The updated area for the permitted ENRMF site is 317,600m<sup>2</sup> hence the slight discrepancy between the predevelopment and restored site catchments.

4 Restored site additional areas comprise managed grassland standoff areas round the perimeter of the site and in the pipeline corridors and perimeter boundary areas. In general, these areas are at shallow topographical gradients with drainage ditches upgradient from these areas collecting the majority of surface water runoff from the site.

Table 2

## Upstream catchment areas

<b>Catchment upstream of the western extension</b>	<b>Area (m<sup>2</sup>)</b>	<b>Location to which the catchment area drains</b>
Area to the north west drains to the northern part of the northern area	43,900	To the eastern drainage ditch
Area to the north west drains to south of the northern area and the central area	41,000	To the swallow hole
Area to the south west drains to the central area	207,050	To the swallow hole
Areas to the north west, west and south west drains to the west of the site	233,200	Drains to dolines to the west of site
Area to the south west drains to southern area	7,750	To southern drainage ditch

**FIGURES**

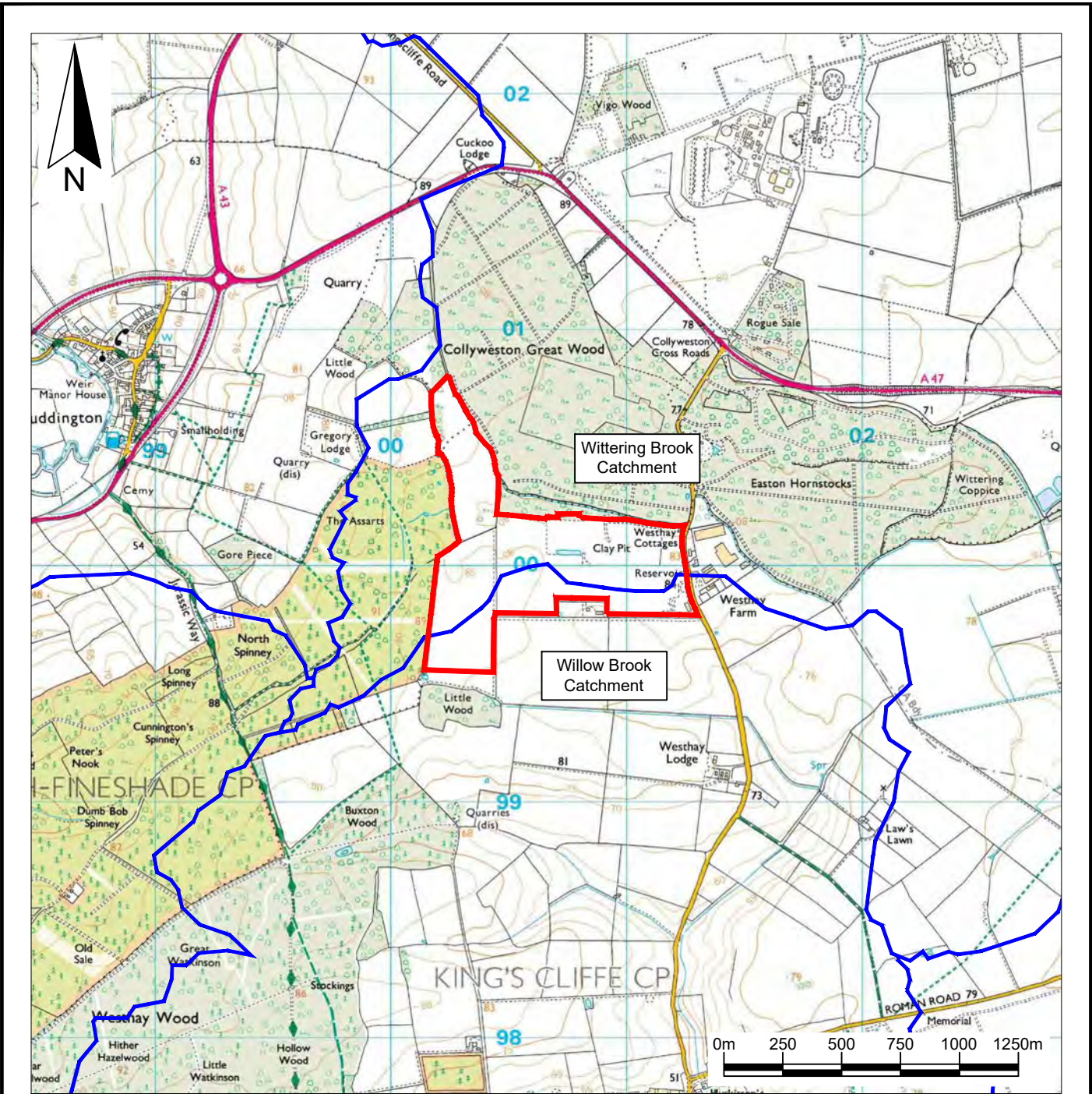

**Key / Notes**

- Approximate boundary of the area the subject of the application for the Development Consent Order
- Catchments defined on Environment Agency Catchment Data Explorer website

	Final	KR	JRC	LH	26/07/21
Rev	Status	Drn	App	Chk	Date
Site EAST NORTANTS RESOURCE MANAGEMENT FACILITY					
Client 					
Title Documented surface water catchments					
Figure 1				Scale 1:25,000@A4	
Drawing Ref AU/KCW/03-21/22297					



Baddesley Colliery Offices,  
Main Road, Baxterley, Atherstone,  
Warwickshire, CV9 2LE.  
Telephone : 01827 717891  
Fax : 01827 718507

Reproduced scale mapping by permission of Ordnance Survey on behalf of The Controller of Her Majesty's Stationery Office. © Crown copyright 2017. All rights reserved. Licence number 100017818.

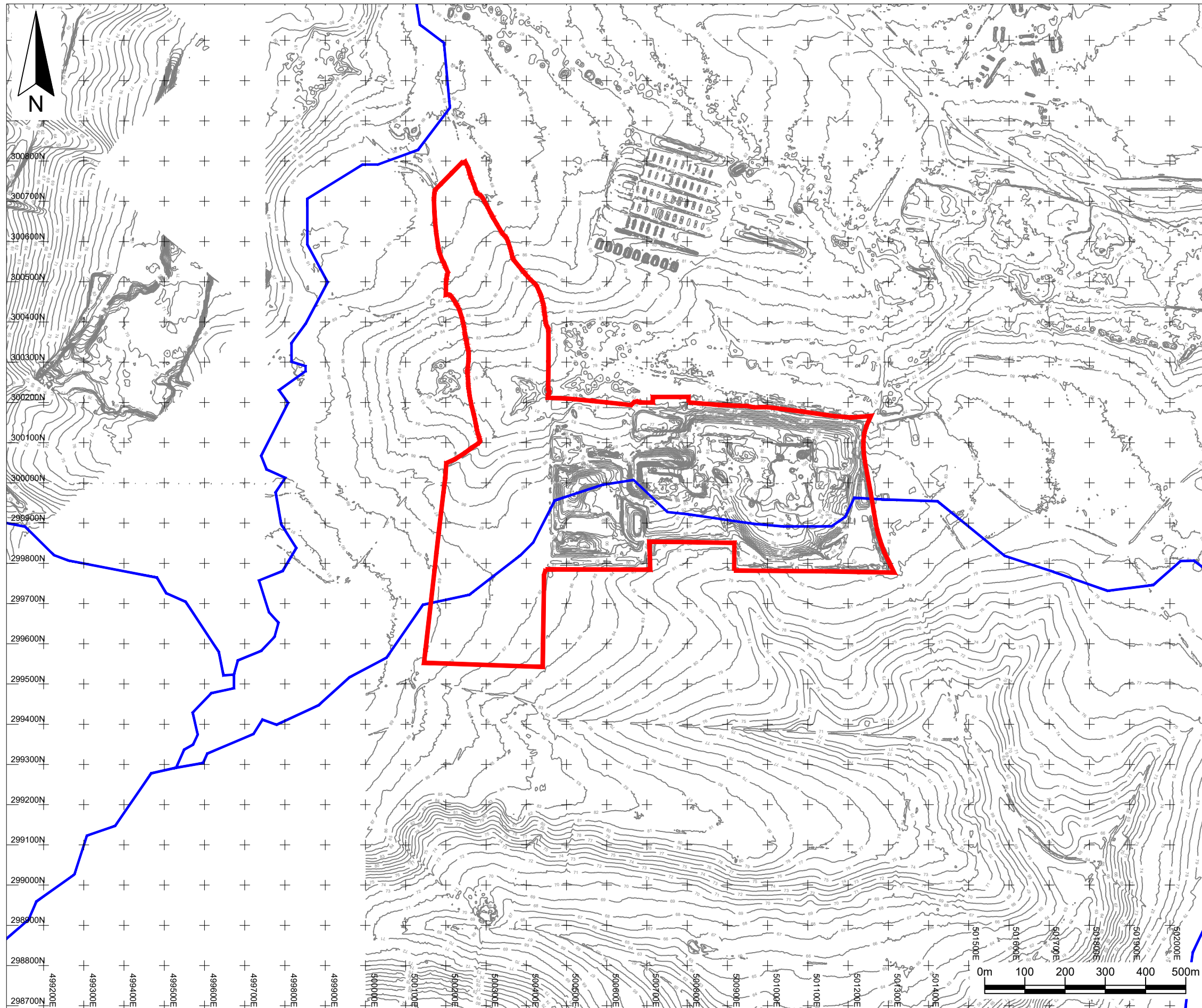

### Key / Notes

- Approximate boundary of the area the subject of the application for the Development Consent Order
- Catchments defined on Environment Agency Catchment Data Explorer website
- LIDAR contours in metres above Ordnance Datum (mAOD)

Rev	Status	Drn	App	Chk	Date
	Final	KR	JRC	LH	26/07/21

Site  
EAST NORTANTS RESOURCE  
MANAGEMENT FACILITY

Client  



Title  
Topographical LiDAR data

Figure 2      Scale 1:10,000@A3

Drawing Ref  
AU/KCW/03-21/22319

Reproduced scale mapping by permission of Ordnance Survey on behalf of The Controller of Her Majesty's Stationery Office. © Crown copyright 2017. All rights reserved. Licence number 100017818.

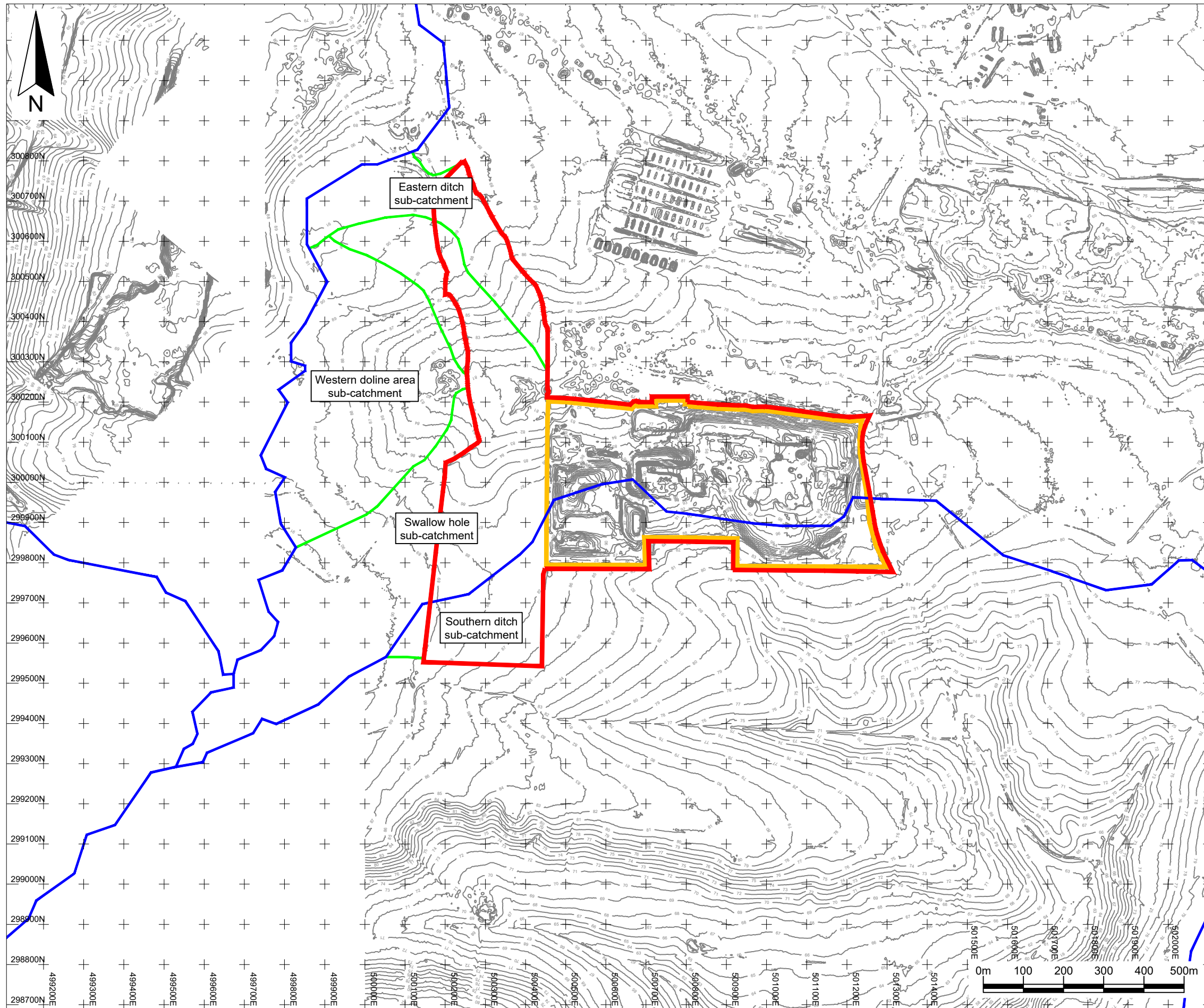
 Baddesley Colliery Offices,  
Main Road, Baxterley, Atherstone,  
Warwickshire, CV9 2LE.  
Telephone : 01827 717891  
Technical advisers on environmental issues Fax : 01827 718507



### Key / Notes

- Approximate boundary of the area the subject of the application for the Development Consent Order
- Current ENRMF site
- Catchments defined on Environment Agency Catchment Data Explorer website
- Sub-catchments interpolated from the LIDAR data
- LIDAR contours in metres above Ordnance Datum (mAOD)

Rev	Status	Drn	App/Chk	Date	
	Final	KR	JRC LH	26/07/21	

Site  
EAST NORTANTS RESOURCE MANAGEMENT FACILITY

Client

Title  
Sub-catchments at and in the vicinity of the site

Figure 3 Scale 1:10,000@A3

















Drawing Ref  
AU/KCW/03-21/22354

Reproduced scale mapping by permission of Ordnance Survey on behalf of The Controller of Her Majesty's Stationery Office. © Crown copyright 2017. All rights reserved. Licence number 100017818.

Baddesley Colliery Offices,  
Main Road, Baxterley, Atherstone  
Warwickshire, CV9 2LE.  
Telephone : 01827 717891  
Technical advisers on environmental issues Fax : 01827 718507



**Key / Notes**

-  Approximate boundary of the area the subject of the application for the Development Consent Order
-  Indicative surface water drainage ditches
-  Proposed restoration contours (at 1m intervals)
-  Proposed locally native broadleaved woodland
-  Proposed scrub/natural regeneration broadleaved woodland within grassland areas
-  Proposed individual tree or small tree group
-  Existing hedgerow reinforced with trees/shrubs
-  Proposed hedgerow
-  Proposed hedgerow with trees
-  Existing agricultural land to remain as undisturbed standoff, to provide a number of ecological functions
-  Existing species-rich neutral/calcareous grassland to be retained
-  Proposed neutral/calcareous grassland (depending on soil type)
-  Existing pond to be retained
-  **Basin C4** Proposed attenuation feature (lowest areas to act as ephemeral ponds to enhance biodiversity)
-  Approx. 0.5m high bund around attenuation pond 1 to contain 1 in 100 year event. bund to be planted with scrubby species
-  Public car park area accessed from existing main site entrance.

Note:  
Based on file reference  
210520\_008.006\_ENORTH25\_Final Rest  
Plan\_Df5.dwg dated May 2021

Rev	Status	Drn	App	Chk	Date
	Final	KR	JRC	LH	26/07/21

Site  
EAST NORTHANTS RESOURCE  
MANAGEMENT FACILITY

Client  



Title  
Indicative surface water drainage ditches

Figure 4      Scale  
1:5,000@A3

Drawing Ref  
AU/KCW/05-21/22467



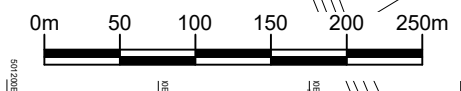











Reproduced scale mapping by permission of Ordnance Survey on behalf of The Controller of Her Majesty's Stationery Office. © Crown copyright 2017. All rights reserved Licence number 100017818.

 Baddeley Colliery Offices,  
Main Road, Baxterley, Atherstone  
Warwickshire, CV9 2LE.  
Telephone : 01827 717891  
Technical advisers on environmental issues Fax : 01827 718507





### Key / Notes

-  Approximate boundary of the area the subject of the application for the Development Consent Order
-  Proposed restoration contours (at 1m intervals)
-  Proposed locally native broadleaved woodland
-  Proposed scrub/natural regeneration broadleaved woodland within grassland areas
-  Proposed individual tree or small tree group
-  Existing hedgerow reinforced with trees/shrubs
-  Proposed hedgerow
-  Proposed hedgerow with trees
-  Existing agricultural land to remain as undisturbed standoff, to provide a number of ecological functions
-  Existing species-rich neutral/calcareous grassland to be retained
-  Proposed neutral/calcareous grassland (depending on soil type)
-  Existing pond to be retained
-  Proposed attenuation feature (lowest areas to act as ephemeral ponds to enhance biodiversity)
-  Approx. 0.5m high bund around attenuation pond 1 to contain 1 in 100 year event. bund to be planted with scrubby species
-  Public car park area accessed from existing main site entrance.

Note:  
Based on file reference  
210520\_008.006\_ENORTH25\_Final Rest  
Plan\_Dft5.dwg dated May 2021

Rev	Status	Drn	App	Chk	Date
	Final	KR	JRC	LH	26/07/21

Site  
EAST NORTANTS RESOURCE  
MANAGEMENT FACILITY

Client  

Title  
Restored surface water catchments

Figure 5      Scale 1:5,000@A3

Drawing Ref  
AU/KCW/05-21/22466

Reproduced scale mapping by permission of Ordnance Survey on behalf of The Controller of Her Majesty's Stationery Office. © Crown copyright 2017. All rights reserved Licence number 100017818.

 Baddeley Colliery Offices,  
Main Road, Baxterley, Atherstone  
Warwickshire, CV9 2LE.  
Telephone : 01827 717891  
Technical advisers on environmental issues Fax : 01827 718507



**APPENDICES**

**APPENDIX A**  
**SURFACE WATER MANAGEMENT PLAN DATED MAY 2007**



**Augean plc**

**Kings Cliffe Landfill**

**SURFACE WATER MANAGEMENT PLAN**



**May 2007**

**e**gniol

Client : Augean plc  
Project Title : Surface Water Management Plan  
Site: Kings Cliffe LFS  
Project No. 1621  
Project Director: John Marshall  
Project Manager: John Marshall

Egniol Consulting Ltd  
Primtec House  
Hulme Lane  
Lower Peover  
Nr Knutsford  
Cheshire  
WA16 9QQ

Tel. 01565 723618  
Fax. 01565 723945

**Distribution:** Egniol Consulting Ltd - Lower Peover (1 copy)  
Augean (5 copies)  
Environment Agency

**CONTENTS**

	<b>Page No.</b>
1.0 INTRODUCTION	3
2.0 PRESENT SITUATION	5
3.0 SOURCES OF POLLUTION	7
4.0 PATHWAYS AND RECEPTORS	8
5.0 PROPOSED SURFACE WATER MANAGEMENT	9
6.0 MONITORING	15
7.0 CONCLUSION	18

**APPENDICES**

Appendix A – Estimation of Acceptable Runoff From Site

    Percentage Runoff Calculations

    Calculations to Determine Particle Settling Velocities

    Rating for the orifice on Kings Cliffe South East Pond

Appendix B – Micro Drainage Output – Northern Catchment

Appendix C – Micro Drainage Output – Southern Catchment

Appendix D – Flood Analysis of Highway culvert

Appendix E – Micro Drainage Output – Flood Analysis of Highway culvert

Appendix F – Baseline Monitoring Results

Appendix G – Drawing 1621.SWM.10 – “Surface Water Management - Outline Surface Water Drainage Proposals” (Post Restoration Contours)

Appendix H – Drawing 1621.SWM.11 – “Surface Water Management - Construction Details for NW Pond”

Appendix I – Drawing 1621. SWM.14 – “Outfall Details for SE Pond”

Appendix J – Drawing 1621. SWM.24 – “Progressive Waste Fill”

## 1.0 INTRODUCTION

- 1.1. Egniol Limited was commissioned by Wastego, now part of Augean plc, to prepare a surface water management (SWM) design and risk assessment for the Kings Cliffe Landfill Site (*the Site*). The site is licenced under the Pollution Prevention and Control (England and Wales) Regulations 2000 for co disposal of waste in Cells 1 and 2 and hazardous waste in Cells 3, 4 and 5. This report supports a variation notice application to the Environment Agency (EA).
- 1.2 The purpose of the assessment is to determine whether the site restoration proposals and surface water management design pose an unacceptable risk to surface and groundwater and whether proposed mitigation measures are sufficiently robust to reduce/control those risks to an acceptable level.
- 1.3 The report will review the present situation and assess the risks based on the progressive site development. The risk will be in the context of the source, pathway, receptor style of approach with appropriate engineering design to address it. Consideration is then given as to how the engineering measures are controlled and monitored for performance to ensure that they continue to meet site operations and environmental need.
- 1.4 Subsurface flow within the site, if any, has been ignored since this assessment deals purely with surface water runoff. The hydrogeological aspect of the site development is covered by Environmental Simulations International Ltd in a separate risk assessment.
- 1.5 Proposed discharge rates of runoff to off site are expressed in terms of "Greenfield" rates. There are calculations in Appendix A to identify how this rate has been computed as well as a prediction of the percentage runoff (PR) for the restored site.

The particle settlement calculations for the efficiency of the north and south ponds are also given in Appendix A.

- 1.6 Calculations for the predicted performance of the ditches and attenuation ponds have been produced using the Flood Studies Report in the MicroDrainage software. The calculations are included in Appendix B and C.

## **2.0 PRESENT SITUATION**

- 2.1 There is little active management of surface water runoff beyond the fence boundary at present. What is in place is a passive system of embankments along the whole of the eastern and part of the southern elevations and these jointly serve as visibility bunds to obscure site operations. Active landfilling operations are confined well within the site and road sweeping is carried out both on the public highway and the site access roads and weighbridge area.
- 2.2 The intermittent perimeter bund, nominally two metres high, on the southern and eastern boundaries from the wheelwash eastwards to the site entrance entraps surface runoff from the access road and the MRF area. There is a pond on the southern boundary that does not have an overflow but is monitored for level and has 600mm nominal freeboard to the southern boundary. The pond is used as a source for watering for dust suppression.
- 2.3 It is expected that the present system of surface water management for the southern catchment will be changed when the construction of the new lagoon to the south east corner replaces the present one on the southern boundary. The new lagoon will then be able to receive runoff from the rolling programme of restoration when this commences.
- 2.4 The eastern perimeter bund extends northwards from the site entrance and stands nominally 2 - 4 metres high above normal ground level and becomes part of the batter to Cell 2 at the north east corner of the site. Surface runoff along the eastern boundary is prevented from leaving the site by the bund. On the northern batter, proposals are in hand and discussed below, to entrap surface runoff before it reaches the site perimeter. This runoff will be directed westwards to the proposed settlement / attenuation pond to be constructed under the surface water management proposals.



- 2.5 There is no identified runoff from the western and south western horizons of the site as this is undeveloped.
- 2.6 At present surface water collecting within unlined cells is encouraged via grips to fall into a collection lagoon/sump located at the lowest point within this area. This provides initial storage capacity and settlement of suspended solids. A pump is used to pump water to the settlement pond on the southern boundary.
- 2.7 To minimise surface run off from the side-slopes into active landfill areas, temporary cut-off trenches can be provided as required to intercept the flow and route it to the perimeter cut-off ditches and thence to the above pond for settlement.

### 3.0 SOURCES OF POLLUTION

- 3.1 The main sources of potential contamination are from the waste, site engineering/development, the drum storage / skip / lorry park area and the materials recycling facility (MRF). The surface water runoff from these areas is designed to be captured within the on-site drainage system.
- 3.2 The skip / lorry park / drum storage area presently consists of imported stone overlying compacted clay. There is no formal sub surface drainage system but ground levels trend northwards towards the centre of the site.
- 3.3 The general level of the limestone aquifer under the skip / drum storage area is 72mAOD and the ground level 83.5mAOD. The natural clay has a permeability of  $1 \times 10^{-5}$  m/s so a thickness of 11m or so provides a good level of protection to the limestone.
- 3.4 The northern catchment of the site comprises Cells 1 and 2 and has a steep batter on the northern site boundary. This potentially could shed polluted runoff off site. There are no receiving waters on this boundary and runoff tends to form localised pond areas. On the eastern horizon the cell batter runoff is contained by the visibility bund which is some 3 - 4 metres high at this point.

#### **4.0 PATHWAYS AND RECEPTORS**

4.1 The main receptors for any potential contamination are groundwater via the swallow hole to the north, the northern off site boundary along Cells 1 and 2 and the receiving watercourse in the valley to the south of the site.

##### **Swallow Hole**

4.2 The swallow hole lies in woodland some 20m north ( NGR 500470, 300240) of the north west corner of the site and provides a natural sink for pre development site runoff to issue directly to groundwater. Runoff from surrounding agricultural land already gravitates to the swallow hole via a system of field ditches.

4.3 The other pathway which could pose a risk to groundwater contamination here is from discrete seepage from peripheral ditches installed as part of the proposed surface water management scheme or overland flow from a proposed pond.

##### **Northern Boundary – Cells 1 and 2**

4.4 Runoff from the northern batter of Cells 1 and 2 is free to issue off site and could percolate into groundwater if the overburden soils of the aquifer are conducive to it.

##### **Unnamed Watercourse, South of the Site**

4.5 There is no direct connection with the watercourse and the site at present as the two are remote. It is proposed, however, under the surface water management plan to issue site runoff to it.

4.6 The watercourse issues to a road culvert and the capacity of this has been checked to confirm that flooding does not result under design operating conditions.

## 5.0 PROPOSED SURFACE WATER MANAGEMENT

- 5.1 The proposed surface water management system is shown on drawing 1621.SWM.10 in Appendix G. The site restored slopes will be configured into north and south catchment areas. These are referred to as such in the discussion below.
- 5.2 The system will be progressively installed on completion of each cell. The progression of cell construction and filling is shown on drawing 1621.SWM.24 in Appendix J. Surface water ditches will be excavated into the restoration soils to direct run-off into the main perimeter cut-off ditch. The ditch section profile is indicated on drawing 1621.SWM.10 in Appendix G and is integrated with the capping materials.
- 5.3 Site restoration will generally consist of 1metre restoration soils overlying a geomembrane/ clay liner. On the northern batter slopes, a drainage geocomposite with 1mm textured geomembrane clay liner is specified below the restoration soils.

### Northern Site Catchment

- 5.4 The northern catchment will issue into a pond in the north-west corner of the site. The selected location of the proposed pond is ideal as regards its remoteness from working areas as this minimises the probability of accidental contamination. It is in close proximity to road access for service vehicles for the pumping station and overhead power supplies for the pump units. The pond elevation is also conducive to collecting runoff by offering a westerly outfall route from the restored slopes on Cells 1 and 2. An outfall to the east is not readily available. In contrast to these attributes there is the likelihood that the pond may, during its operation, contain contaminated water and this will be stored for assessment prior to licenced disposal. Since the pond will be lined with engineered clay, overtopping and overland routing of water to the swallow hole is the only available pathway of escape to

groundwater. Given the worst case scenario where the pumps fail during the critical 100 year return period storm, it is predicted that there would still be a 46 hour time lapse between failure of the pumps and overtopping of the lagoon. It is considered that this would be ample time to commission tankers onto site to draw down the water levels, restore power supplies or repair/reset stalled pumps. The risk of groundwater contamination via this pathway is therefore considered negligible.

- 5.5 The pumping station will be subject to an annual maintenance agreement with a competent M&E Contractor and this will run for the life of the station. The agreement will stipulate the frequency of non reactive service inspections and the response times for reactive ones. A telemetry outstation will be provided in the pumping station kiosk and this will respond to a landline telephone designated by Augean. In the first instance, this will report faults to the maintenance contractor. The outstation will also have a dial up facility to enable interrogation of the stations' operational status by authorised parties.
- 5.6 Inlet ditches to the pond will be lined with engineered clay and constructed to CQA site standards, as will the ponds. Overtopping will occur at the pond before the ditch and this risk has been discussed and discounted earlier. The risk of contamination of groundwater is therefore considered to be negligible from this source.
- 5.7 A pumped outfall from the pond to the proposed south east pond and then to watercourse south of the landfill site will offer less contamination risk than an outfall to groundwater via the swallow hole to the north. The pumped outfall option has thus been selected for preference but both options have been reviewed for risk.
- 5.8 In the pumped outfall scenario, to achieve a self-cleansing velocity in the rising main commensurate with a pipe diameter to resist blockage, it will be necessary for the outflow from the pond to exceed Greenfield Run-off. MicroDrainage calculations in Appendix E show that even for the critical 1 in 100 year return

period storm, this increased rate of pumping will not cause flooding downstream at the road culvert. The pond has therefore been sized on this rate. The north west pond and pumping station is shown on drawing 1621.SWM.11 in Appendix H.

- 5.9 The proposed pond will have a side slope no steeper than 1 in 3, a width to length ratio of 1 to 3 (recommended for optimum suspended sediment settlement) and a minimum freeboard of 600mm above design top water level. It will incorporate sufficient storage capacity to contain the inflow from the critical long duration storm of 1440minutes assuming that pump failure endures up to 24 hours.
- 5.10 The additional storage capacity provided as a safeguard against overtopping following pump failure, will also allow inflows to be safely contained within the pond so that the water quality can be monitored if pollution is suspected. If the water quality complies with the discharge consent, the pumps can then be re-activated to draw the water level back down and release it at a controlled rate to the south east pond. In normal operation, the pumping station would respond automatically to inflow from rainfall.
- 5.11 In the unlikely event that water sampling reveals substances outside prescribed limits, the water will be treated as leachate and processed at a licenced facility off site.
- 5.12 The inflow ditches to the pond will be lined with clay and dressed in topsoil with ryegrass seed to form a swale. When established, the grass will provide natural filtration and further attenuation. Stone pitching will be provided at the inlets and down the banking to avoid erosion and allow escape. The pond will be fenced and signs erected to warn of deep water.

### Southern Site Catchment

- 5.13 The southern catchment will issue to the proposed south east pond see drawing 1621.SWM.14 in Appendix 1. It is sized to cater for a 1 in 100 year (1% probability) rainfall event and pass forward a controlled discharge to the upstream point of the road culvert. Calculations are included in the report to show that flooding of the culvert for events up to 1 in 100 years is avoided (see Appendix D and E).
- 5.14 The calculations further demonstrate that even without attenuation on site the highway culvert will not flood for the critical 1 in 100 year return period event. However, for the purpose of monitoring and controlling discharges from site a pond has been included in the surface water management of the site.
- 5.15 The outfall will comprise a 225mm diameter pipe laid under Licence in the highway verge to the receiving watercourse, where it will issue at NGR 501480 299360. With *no* orifice control over the 225mm diameter outfall pipe, there would be an outflow rate for the critical 1 in 100 year return period storm of approximately 11 x Greenfield Run-off ( ie 11 x 10l/s). It has been calculated that the downstream highway would have the capacity to receive a discharge rate of greater than 50 x Greenfield Run-off from this pond without being at risk from flooding.
- 5.16 The size of the south east pond will be limited by the presence of the MRF building, the haul road and the minimum easement width for the water mains. Given that the discharge is increased to 5 x 'Greenfield Run-off', it will be possible to design the pond with 1 in 3 side slopes, however the restrictions on space mean that it will not be possible to design the pond to the recommended width to length ratio of 1 to 3.

- 5.17 Details for the rating curve of the orifice outlet and outflow rate are included in Appendix A as Calculation 4.
- 5.18 The capacity of the south east pond is 1506m<sup>3</sup> between incoming invert level and top of bank. The volume used by the 1 in 100 year event is 954m<sup>3</sup> so the volume available as freeboard is 552m<sup>3</sup>. The percentage available volume available for climate change and dilapidation is therefore  $552/954 = 57\%$ , ignoring the silt storage volume of 367m<sup>3</sup>. Silt will be removed for the base of the pond as part of the programmed maintenance regime under the surface water management plan.
- 5.19 Following a request from the EA, the performance of the south east pond has been verified to accommodate 80% of the surface water runoff volume produced by a 1 in 10 year storm of the critical duration 24hrs after it has been filled to design level. The pond is actually predicted to be empty after 960mins (16 hours) from the 100year event. This means that full capacity is available within 24hrs to cater for further events.
- 5.20 In the scenario of a more extreme event than 1 in 100 years, the runoff would back up the incoming ditches utilising available storage within them with a similar rise in the pond level. Out of bank flows will occur in the local ditches to the pond and the pond itself. If the event occurs while the site is still operational it is expected that flow routing will be towards the centre of the site. Should overtopping occur when the site is closed and fully restored, then flood routing will be confined to the south east corner of the site providing the visibility bund is retained.

#### **Northern Slope at Cells 1 and 2**

- 5.21 The northern batter slope is programmed to undergo reprofiling as part of the overall restoration. Under the SWM plan, a collector ditch will be incorporated into the reprofiled batter to prevent off site runoff and issue runoff to the proposed north west pond.



### **Technical Aspects of the SWM Design**

- 5.22 The ditch sections in the SWM design are chosen to provide a minimum level of service of no flooding during a 1 in 10 year event. To reduce ravelling, and the risk of eroding the capping / liner, intermediate ditches will be provided on the batter slope. As the landform settles, ditches may need to be realigned to maintain gradient.
- 5.23 Design calculations in support of the proposed Surface Water Management Scheme are included in the Appendices. The settlement ponds have been designed in accordance with "Design of Flood Storage Reservoirs" published by CIRIA and discharge rates determined by use of the Flood Studies Report / Flood Estimation Handbook.
- 5.24 Construction of surface water management infrastructure will be subject to Construction Quality Assurance supervision to ensure that the Works are built in accordance with the Drawings

## 6.0 MONITORING

### Baseline Monitoring at Existing Receptors

- 6.1 Baseline monitoring has been carried out by recovering samples of water from the two obvious inlet points to the swallow hole and the reception point at the southern watercourse. The results are tabulated in Appendix F.
- 6.2 For both the present northern and southern issues into the swallow hole (sample location reference SW SWALL N and SW SWALL S), measured levels of 0.4mg/l Ammoniacal Nitrogen exceed DWS levels of 0.35mg/l. Samples recovered after implementation of the surface water management scheme from the proposed pond on the northern catchment will be compared against the baseline results for the issue into the swallow hole from the south.
- 6.3 The outfall for the southern and northern catchments is at the confluence of the watercourse as it leaves arable land and a roadside ditch accepting direct runoff from the carriageway (sample location reference SW Field RO and SW Road RO). Baseline sampling from the arable land reach of the watercourse has been undertaken on the 8<sup>th</sup> February and the 2<sup>nd</sup> and 24<sup>th</sup> March 2005. Samples of road runoff were recovered on the 14<sup>th</sup> and 19<sup>th</sup> October 2005.
- 6.4 Comparison has been made against Drinking Water Standards (DWS) in accordance with the Water Supply (Water Quality) Regulations 2000.

### Arable Land Runoff

- 6.5 Conductivity is recorded (2 March 2005) as 2770 $\mu$ s/cm which is >1500 $\mu$ s/cm DWS. Cadmium is 0.001mg/l which is >0.1 $\mu$ g/l MRV but <0.005mg/l DWS (24 March 2005). Ammoniacal Nitrogen of 0.5mg/l is > DWS of 0.35mg/l (24 March

2005). Mecoprop of 0.186µg/l is > 0.04µg/l MRV and the 0.1µg/l DWS (24 March 2005). All of the above determinations are in low concentrations.

### **Road Runoff**

- 6.6 Baseline monitoring was undertaken in October 2005 when sufficient rainfall was evident to provide a sample. The results are included in Appendix F.
- 6.7 Ammoniacal Nitrogen is 0.5mg/l and <0.3mg/l which is close to DWS of 0.35mg/l. Mecoprop of <0.04µg/l is similar to the MRV of 0.04µg/l. All of the above determinations are low concentrations.

### **Future Monitoring**

- 6.8 The ponds offer the opportunity to analyse stored water for potential contamination and it is proposed that sampling be undertaken on an initial two weekly basis to establish the quality of the first inflows. After this period a monthly programme can be initiated. This will allow the operator to classify whether the water lies within EA agreed threshold limits for its controlled disposal. Testing will be carried out in accordance with the Environmental Monitoring Plan.
- 6.9 As an additional safeguard, routine walk over inspections will continue to be to alert to irregularities in the landform which could indicate the capping membrane to have ripped and any unusual discolourations on the landform which could indicate the presence of a contaminant. If a potential contamination hazard is identified, water samples will be recovered for testing in accordance with the Environmental Monitoring Plan.
- 6.10 The decision to pump runoff from the northern catchment does not offer an ideal, sustainable solution to dispose of rainfall since power usage is dictated by the vagaries of the weather. The choice of this option should, however, be viewed in

the context of the risk to groundwater against the capital and revenue cost of the station. To estimate the station cost, it is necessary to attempt a forecast of the likelihood that polluted flows may issue to it in the years to come against the residual risk when the station is decommissioned and flow is diverted to the swallow hole.

- 6.11 The purpose of the pumping station at the north western corner of the site is to effect control over potentially contaminated surface water drainage from the landfill. There is a potential for contamination of surface water during the operational period and in the period following capping and restoration due to contamination of run off, perched leachate and erosion. As leachate collecting in the base of the cell is managed at a level several metres below ground level it does not present a risk to the surface water system. The installation of the landfill cap, placement of soils and the establishment of a vegetated surface will provide a barrier to contaminants and prevent erosion. The most active stage of biodegradation and settlement hence disturbance of the landfill surface occurs in the first five years after landfilling. It is anticipated that the landfill surface will become increasingly stable and the risk of significant contamination of surface water run-off will progressively reduce. Surface water draining from the northern part of the site will continue to be pumped to the south eastern lagoon until the quality of the drainage is consistently acceptable. At this time, subject to the agreement of the Environment Agency, the discharge from the north western pond will be diverted to the swallow hole.

## 7.0 CONCLUSION

- 7.1 This risk assessment examines the potential impact of contaminated surface water runoff from the site on the surrounding environment. It discusses the source, severity of the risk, the likelihood of it occurring and the protocol provided to contain it. Providing the routing of surface runoff and the containment of it is maintained then the sampling regime should adequately monitor the site generated flows.
- 7.2 The storage ponds represent an opportunity for intercepting potentially contaminated flows from escaping to the environment. In designing the ponds, careful consideration has been given to ensure that they are both adequate to afford protection against downstream flooding and sufficiently sized to allow a response to a pollution incident. The ponds also incorporate protective fencing and means of escape via hard paved inflow channels set at manageable gradients.
- 7.3 The ponds have penstock controls incorporated at the outlet. The flow control on the south east pond is a simple orifice plate which regulates discharge to prescribed limits. This can be removed by unbolting in the event of blockage. If desilting of the ponds is required, the penstock can be closed to prevent onward passage of silts to the outfall.
- 7.4 Settling of solids is a primary function of both the ponds and the geometry has been carefully configured to dissipate energy from incoming turbulent flow during storm events. The ponds are both to have at least one metre of water below the outlet level which will provide inertia to reduce inlet velocity. Sumps have been incorporated into the base to collect solids and aid removal.
- 7.5 Freeboard of 600mm for the 1 in 100 year event is provided to contain flows and safeguard against offsite flood routing.

- 7.6 Outflow through the northern pond will be controlled by a pumping station which will regulate the discharge to that required for self cleansing of the rising main. If desilting of the pond is required, the pump can be simply turned off and the silt withdrawn by a portable sludge pump into a bowser for licenced disposal. A similar procedure will be adopted for the south east pond once the outlet penstock is closed. Calculations are included in the Appendices to show that the receiving watercourse is adequate to accept the flow
- 7.9 Flood routing and the passage of contaminated water within final paved areas will be effectively curtailed by the use of ground profiles in the form of kerbs and highway ramps.
- 7.10 Testing of contained water in the surface water lagoons will be undertaken in accordance with the Environmental Monitoring Plan. Records of sampling data shall be available for scrutiny by the Environment Agency at all reasonable times to offer assurance that compliance to agreed discharge criteria is being adhered to. Sampling data will be sent the EA on a quarterly basis and non conformances sent immediately via a Schedule 1.

**APPENDIX A**

**CALCULATIONS**

**CALCULATIONS 1 - ESTIMATION OF ACCEPTABLE RUN OFF FROM SITE*****Northern Catchment***

Determine Q ( mean annual flood ) using FSR for each catchment

From FSR Supplementary Report No 6,

$$Q = 0.00066 \times \text{AREA}^{0.92} \times \text{SAAR}^{1.22} \times \text{SOIL}^2$$

$$\text{Total contributing AREA} = 6.7 \text{ ha} = \underline{0.067 \text{ km}^2}$$

Kings Cliffe National Grid Ref – 500500E 300500N

From Fig II 3.1 (S) » SAAR = 580mm

From Fig I 4.18 (S) »  $S_1 = 100\%$

$$\text{SOIL} = \frac{0.15S_1 + 0.3S_2 + 0.45S_3 + 0.45S_4 + 0.5S_5}{S_1 + S_2 + S_3 + S_4 + S_5}$$

$$\underline{\text{SOIL} = 0.15}$$

$$\text{Therefore } Q = 0.00066 \times 0.067^{0.92} \times 580^{1.22} \times 0.15^2$$

$$\underline{Q_{\text{NORTH}} = 2.91 \text{ l/s}}$$

***Southern Catchment***

From FSR Supplementary Report No 6,

$$Q = 0.00066 \times \text{AREA}^{0.92} \times \text{SAAR}^{1.22} \times \text{SOIL}^2$$

$$\underline{\text{AREA} = 0.2572 \text{ km}^2}$$

$$\underline{\text{SAAR} = 580\text{mm}}$$

$$\underline{\text{SOIL} = 0.15}$$

$$\text{Therefore } Q = 0.00066 \times 0.2572^{0.92} \times 580^{1.22} \times 0.15^2$$

Using the southern catchment area, Q<sub>south</sub> = 10 l/s



**CALCULATIONS 2 - PERCENTAGE RUN OFF CALCULATIONS**

Calculate the predicted percentage run off for the restored site

From "Design of Flood Storage Reservoirs" (CIRIA)

$$PR_{RURAL} = SPR + DPR_{CWI} + DPR_{RAIN}$$

$$\text{Where } SPR = 10 S_1 + 30 S_2 + 37 S_3 + 47 S_4 + 53 S_5$$

Restoration soils will be approximately 800mm deep over HDPE membrane or engineered clay cap.

T 4.5 (FSR Vol 1 )

Drainage Group = 1 ( Rarely waterlogged within 60cm )

Depth to impermeable layer > 80cm

Permeability Group above Imp layer = Medium

Slope > 8°

Therefore Soil Class = 2 so S2 = 100%

$$SPR = 30.1 = 30$$

$$DPR_{CWI} = 0.25 ( CWI - 125 )$$

Kings Cliffe Grid Ref 500500E 300500N

From FSR Fig II 3.1 (S) SAAR = 580mm

FSR Fig I 6.62 CWI = 47

$$\text{Therefore } DPR_{CWI} = 0.25 ( 47 - 125 ) = -19.5$$

$$DPR_{CWI} = -19.5$$

$$DPR_{RAIN} = 0.45 ( P - 40 )^{0.7}$$

Where P = Rainfall( in mm ) for the design event

For Kings Cliffe M5 - 60 = 20mm

$$R = 0.42$$

Critical Duration = Time of Entry + Time of Flow

Maximum length of ditch to outfall = 500m

Assume flow velocity in ditch of 0.4m/s

Assume overland flow velocity of 0.1m/s

So  $T_e = \frac{\text{Distance from catchment boundary to furthest ditch}}{\text{Overland flow velocity}}$

$$= \frac{135\text{m}}{0.1 \times 60}$$

$$T_e = 22.5\text{mins}$$

$$T_c = T_e + T_f$$

$$\text{So } T_c = 22.5 + \frac{500}{0.4 \times 60} = 43 \text{ mins}$$

Critical Duration = 43 mins

Z	M100 - 30	M100 - 60	M100 -120
Z1	0.8	1	1.6
Z2	1.99	2.03	1.95

Therefore

$$\begin{aligned} \text{M100 - 30} &= 20 \cdot 0.8 \cdot 1.99 = 32 \quad \text{So } P_{30} = 32 \text{ mm} \\ \text{M100 - 60} &= 20 \cdot 1.0 \cdot 2.03 = 40.6 \quad \text{So } P_{60} = 40 \text{ mm} \\ \text{M100 - 120} &= 20 \cdot 1.6 \cdot 1.95 = 62.4 \quad \text{So } P_{120} = 62\text{mm} \end{aligned}$$

$$\text{So } \text{DPR}_{\text{RAIN}} = 0.45 (P - 40)^{0.7}$$

$$\text{For } T_c = 60\text{mins}, \quad \text{DPR}_{\text{RAIN}} = 0.45 (41 - 40)$$

$$\text{DPR}_{\text{RAIN}} = 0.45$$

$$\text{Therefore } \text{PR}_{60} = 30 + (-19.75) + 0.45$$

$$\text{PR}_{60} = 10.7\%$$

$$\text{For } T_c = 30 \text{ mins}, \quad \text{DPR}_{\text{RAIN}} = 0 \quad (P < 40)$$

$$\text{So } \text{PR}_{30} = 30 + (-19.5) + 0$$

$$\text{PR}_{30} = 10.5\%$$

$$\text{For } T_c = 60 \text{ mins}, \quad \text{DPR}_{\text{RAIN}} = 0.45 (40 - 40)^{0.7}$$

$$\text{DPR}_{\text{RAIN}} = 0$$

$$\text{So } \text{PR}_{60} = 10.5\%$$

For  $T_c = 120$  mins,  $DPR_{RAIN} = 0.45 (62 - 40)^{0.7}$

$$DPR_{RAIN} = 3.91$$

So  $PR_{120} = 30 - 19.5 + 3.91$

$$PR_{120} = 14.41\%$$

say

Percentage Runoff for the restored site = 12.5%

### CALCULATIONS 3 - DETERMINING PARTICLE SETTLING VELOCITIES

Assess terminal velocity of settlement of fluvial deposits in balancing pond using "Design of Flood Storage Reservoirs" by CIRIA.

From para 6.5.1

The settlement velocity of a sphere of given diameter,  $d$ , is derived from the drag force,  $C_d$  and Reynolds Number,  $Re$ , expressed in two dimensional groups:-

$$\frac{C_d}{Re} = \frac{4}{3} \frac{((\rho_p - \rho) g \mu)}{\rho^2 v_s^2} \quad \text{Equation 6.2}$$

$$C_d \cdot Re^2 = \frac{4}{3} \frac{(\rho(\rho_p - \rho) g d^2)}{\mu^2} \quad \text{Equation 6.3}$$

Where  $g$  = gravitational acceleration  $9.81 \text{ m/s}^2$

$\mu$  = absolute viscosity of the fluid ( $\text{Ns/m}^2$ )

$\rho_p$  = particle density ( $\text{kg/m}^3$ )

$\rho$  = fluid density ( $\text{kg/m}^3$ )

Assume the particle size will arise from use of the granular restoration soils. Also check the efficiency of the designed ponds to cater for clay content if the restoration soils are taken from soil arising from waste inputs.

So for restoration soils:-

$\mu$ metres	% Passing
20	65
60	100

Where

- < 2  $\mu\text{m}$  is clay
- 2 - 6  $\mu\text{m}$  is fine silt
- 6 - 20  $\mu\text{m}$  is medium size silt
- 20 - 60  $\mu\text{m}$  is coarse silt
- 60 - 200  $\mu\text{m}$  fine sand

Determine the particle settling velocity for 20µm particles settling in water at 20° C. Assume a specific gravity of 2.4.

Check  $v_s$  for 20µm size particles;-

$$\text{Cd. } Re^2 = \frac{4}{3} \left( \frac{\rho(\rho_p - \rho) g d^2}{\mu^2} \right) \quad \text{Equation 6.3}$$

$$= 0.076$$

From Fig 6.7  $Re = 0.04$

As Reynolds Number is < 1, Stokes Law is valid and settlement is in the laminar range.

So from Cd.  $Re^2 = 0.076$

$$Cd = 47.5$$

And  $v_s = 2.6\text{mm/s}$  ( 20µm particle)

Similarly,  $v_s$  for 60µm gives  $Re = 0.23$  ( laminar) and  $Cd = 38.94$

and  $v_s = 4.98\text{mm/s}$  ( 60µm particle)

#### Determine the trap efficiency of the North West Pond

From Design of Flood Storage Reservoirs Para 6.5.3

$$\text{Trap efficiency} = \eta = \frac{v_s t_R}{d_1}$$

where  $v_s$  = Settling velocity  
 $t_R$  = Mean hydraulic residence time  
 $d_1$  = Flowing layer mean depth of flood basin

Check  $\eta$  for 20µm and 60µm particles

For 20µm, Volume = L x B x H

Size of pond at Bottom Water Level (BWL) is 161.38m<sup>2</sup> and at Top Water Level (TWL) 305m<sup>2</sup>. Average surface area is (305 + 161) 0.5 = 233 m<sup>2</sup>. The Pond has 1 in 3 side slopes.

Depth of pond for a 1 in 100 year event = TWL – BWL = 79.02 – 78.25 = 0.77m

At the 1 in 100 year event the pond is technically full plus the 1000mm freeboard.

Size of the pond at mid depth = 233m<sup>2</sup>

So volume = 233x 0.77 = 179m<sup>3</sup>

Mean hydraulic residence time  $t_R = \frac{Vol}{Q}$

Where Q = steady state inflow / outflow. This is not feasible for attenuation ponds where inflow / outflow ratios will change, so use outflow rate.

So  $t_R = \frac{179}{0.0147} = 12,176s = 3.38$  hours

Mean through flow velocity  $V = \frac{L}{t_R} = \frac{20m}{12,176}$   
 $= 1.64 \times 10^{-3}$  m/s

for 20µm particles, where  $v_s = 2.66$ mm/s

$$\eta = \frac{v_s \times t_R}{d_p} = \frac{2.66 \times 10^{-3} \times 12176}{0.77}$$

$$\eta = 42 \text{ Satisfactory}$$

Therefore all of the remaining 20µm particles would be trapped in 1/42 the length of the ponds. The Erosamat lining and grass within the outfall ditches would entrap fluvial fine silts also.

### **CALCULATION 4 – RATING FOR THE ORIFICE ON KINGS CLIFFE SOUTH EAST POND**

#### **Rating Curve for Orifice on Kings Cliffe South East Pond**

$$Q = Cd A (2gH)^{0.5}$$

Cd	A	2g	H	Qm3/s
0.6	0.0172034	19.62	0.2	0.020
0.6	0.0172034	19.62	0.4	0.029
0.6	0.0172034	19.62	0.6	0.035
0.6	0.0172034	19.62	0.8	0.041
0.6	0.0172034	19.62	1	0.046
0.6	0.0172034	19.62	1.2	0.050
0.6	0.0172034	19.62	1.4	0.054

The south east pond will operate as the table below. The 240min duration Winter event is the critical event for the catchment:

#### **Rainfall Return Period and Orifice Outflow Rate - South East Pond**

Return Period	1	5	10	30	50	100
Critical Storm	240 Winter	240 Winter	240Winter	240 Winter	240Winter	240Winter
Outflow (l/s)	33	39	42	46	47	50
Top Water Level (m)	83.094	83.312	83.42	83.61	83.7706	83.845
Freeboard (mm)	1256	1038	930	739	644	505
On Site Flooding	None	None	None	None	None	None

The predicted top water level is 83.845mAOD and top of bank level 84.35mAOD

## **APPENDIX B**

### **MICRODRAINAGE OUTPUT – NORTHERN CATCHMENT**



# Calculation Sheet



Client: <b>Augean</b>	Job No: <b>1621</b>	Project: <b>Kings Cliffe SWM.</b>		
Made by: <b>Jenny Mills</b>	Date: <b>Jun 05</b>	Checked by: 	Date:	Sheet No: <b>B Rev A</b>

## Northern Catchment

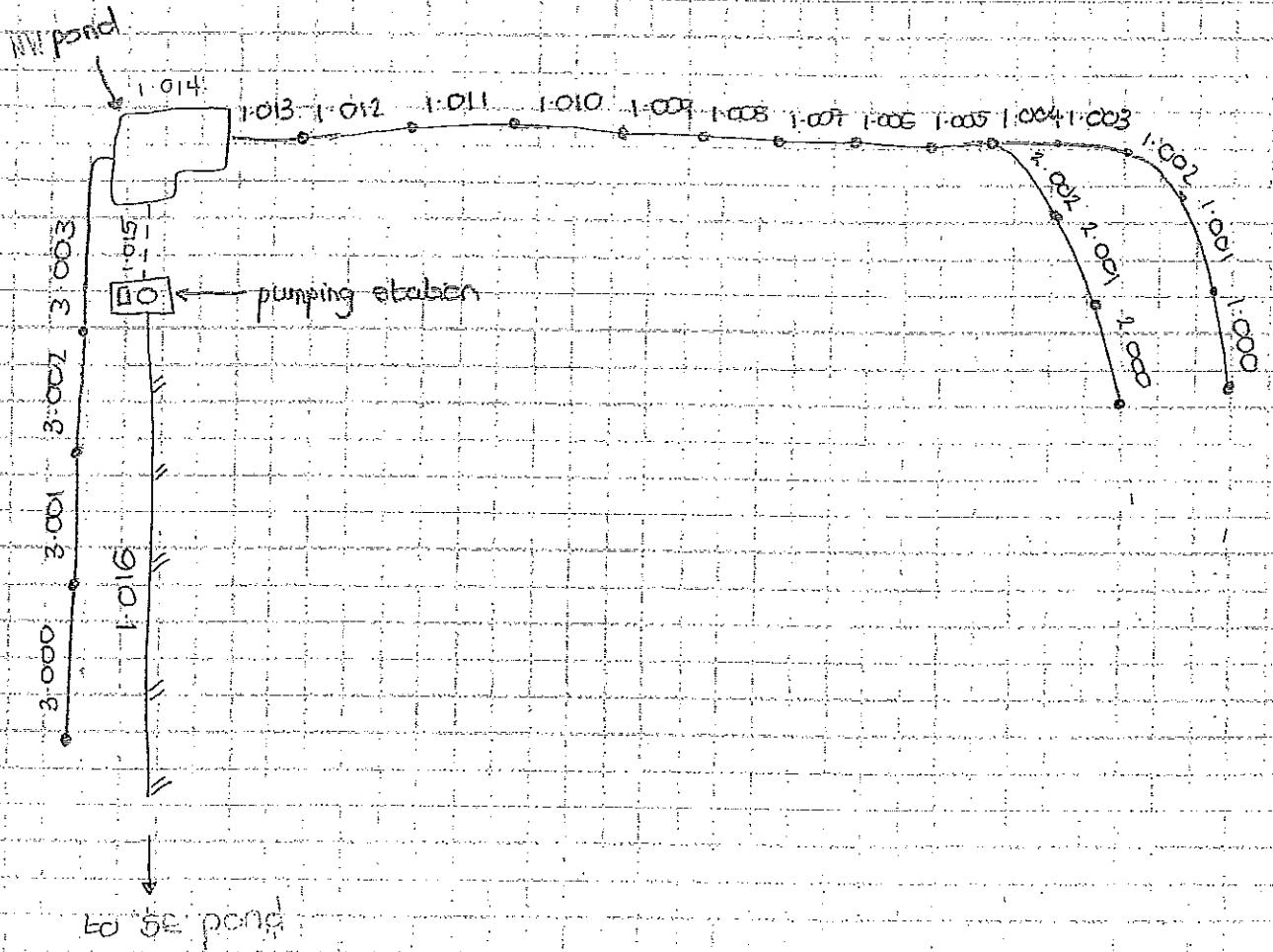

The Felin  
Bangor  
LL57 4LH  
Date Jan-05  
File FSR REV J (09.09.05).SIM  
Micro Drainage

Client: Waste Go  
Project: King's Cliffe  
Title: N. Ditch Network  
Designed By JLM  
Checked By  
Simulation W.9.5



Network Details

\* - Indicates pipe has been modified outside of WinDes's Storm/Foul & Schedules

PN	Length (m)	Fall (m)	Slope (1:x)	Area (ha)	T.E. (mins)	Rain Pro	k (mm)	Hyd Sect	Dia (mm)
1.000	130.00	5.510	23.6	0.133	18.00	1	300.000	∕∕	32
1.001	50.00	0.120	416.7	0.016	0.00	1	300.000	∕∕	32
1.002	50.00	0.130	384.6	0.024	0.00	1	300.000	∕∕	32
1.003	50.00	0.120	416.7	0.013	0.00	1	300.000	∕∕	32
1.004	50.00	0.130	384.6	0.004	0.00	1	300.000	∕∕	32
2.000	126.50	0.720	175.7	0.098	16.00	1	300.000	∕∕	32
2.001	50.00	1.890	26.5	0.026	0.00	1	300.000	∕∕	32
2.002	50.00	5.040	9.9	0.021	0.00	1	300.000	∕∕	32
1.005	50.00	0.130	384.6	0.023	0.00	1	300.000	∕∕	32
1.006	50.00	0.120	416.7	0.023	0.00	1	300.000	∕∕	32
1.007	50.00	0.130	384.6	0.021	0.00	1	300.000	∕∕	32
1.008	50.00	0.120	416.7	0.023	0.00	1	300.000	∕∕	32
1.009	50.00	0.160	312.5	0.022	0.00	1	300.000	∕∕	32
1.010	56.00	0.180	311.1	0.022	0.00	1	300.000	∕∕	32
1.011	101.00	0.320	315.6	0.056	0.00	1	300.000	∕∕	32
1.012	108.00	0.340	317.7	0.090	0.00	1	300.000	∕∕	32
1.013	50.00	0.160	312.5	0.075	0.00	1	300.000	∕∕	32
3.000	65.00	0.200	325.0	0.024	5.00	1	300.000	∕∕	32
3.001	75.00	0.600	125.0	0.022	0.00	1	300.000	∕∕	32
3.002	70.00	2.200	31.8	0.033	0.00	1	300.000	∕∕	32
3.003	90.00	5.000	18.0	0.071	0.00	1	300.000	∕∕	32

PN	USMH No.	US/CL (m)	US/IL (m)	US/Dep (m)	DS/CL (m)	DS/IL (m)	DS/Dep (m)	Ctrl No.	US/MH (mm)
1.000	1	87.670	87.170	0.005	82.160	81.660	0.005		3000
1.001	2	82.160	81.660	0.005	82.040	81.540	0.005	3	3000
1.002	3	82.040	81.540	0.005	81.910	81.410	0.005	3	3000
1.003	4	81.910	81.410	0.005	81.790	81.290	0.005	3	3000
1.004	5	81.790	81.290	0.005	81.660	81.160	0.005	3	3000
2.000	6	89.310	88.810	0.005	88.590	88.090	0.005		3000
2.001	6	88.590	88.090	0.005	86.700	86.200	0.005	3	3000
2.002	6	86.700	86.200	0.005	81.660	81.160	0.005	3	3000
1.005	6	81.660	81.160	0.005	81.530	81.030	0.005	3	3000
1.006	7	81.530	81.030	0.005	81.410	80.910	0.005	3	3000
1.007	8	81.410	80.910	0.005	81.280	80.780	0.005	3	3000
1.008	23	81.280	80.780	0.005	81.160	80.660	0.005	3	3000
1.009	23	81.160	80.660	0.005	81.000	80.500	0.005	3	3000
1.010	23	81.000	80.500	0.005	80.820	80.320	0.005	3	3000
1.011	23	80.820	80.320	0.005	80.500	80.000	0.005	3	3000
1.012	23	80.500	80.000	0.005	80.160	79.660	0.005	3	3000
1.013	23	80.160	79.660	0.005	80.000	79.500	0.005	3	3000
3.000	23	88.000	87.500	0.005	87.800	87.300	0.005		3000
3.001	23	87.800	87.300	0.005	87.200	86.700	0.005	3	3000
3.002	23	87.200	86.700	0.005	85.000	84.500	0.005	3	3000
3.003	23	85.000	84.500	0.005	80.000	79.500	0.005	3	3000

The Felin  
Bangor  
LL57 4LH

Client: Waste Go  
Project: King's Cliffe  
Title: N. Ditch Network



Date Jan-05

Designed By JLM

File FSR REV J (09.09.05).SIM

Checked By

Micro Drainage

Simulation W.9.5

Network Details

PN	Length (m)	Fall (m)	Slope (1:x)	Area (ha)	T.E. (mins)	Rain Pro	k (mm)	Hyd Sect	Dia (mm)
1.014	10.00	1.250	8.0	0.000	0.00	1	300.000	\/	32
1.015	1.00	0.000	30000.0	0.000	0.00	1	0.006	o	225
1.016	760.00	7.325	103.8	0.000	0.00	1	0.006	o	150

PN	USMH No.	US/CL (m)	US/IL (m)	US/Dep (m)	DS/CL (m)	DS/IL (m)	DS/Dep (m)	Ctrl No.	US/MH (mm)
1.014	23	80.000	79.500	0.005	80.000	78.250	1.255	3	3000
1.015		80.000	78.250	1.525	80.000	78.250	1.525	3	1200
1.016	23	80.000	77.300	2.550	87.525	69.975	17.400	5	1800

The Felin  
Bangor  
LL57 4LH

Client: Waste Go  
Project: King's Cliffe  
Title: N. Ditch Network



Date Jan-05

Designed By JLM

File FSR REV J (09.09.05).SIM

Checked By

Micro Drainage

Simulation W.9.5

On-Line Controls (Non Return Valve)

US/PN	Volume (m <sup>3</sup> )	Ctrl MH Name	US/PN	Volume (m <sup>3</sup> )	Ctrl MH Name	US/PN	Volume (m <sup>3</sup> )	Ctrl MH Name
1.000	65.532	2	1.005	24.252	7	1.013	24.252	23
1.001	24.252	3	1.006	24.252	8	3.000	31.992	23
1.002	24.252	4	1.007	24.252	23	3.001	37.152	23
1.003	24.252	5	1.008	24.252	23	3.002	34.572	23
1.004	24.252	6	1.009	24.252	23	3.003	44.892	23
2.000	63.726	6	1.010	27.348	23	1.014	4.076	
2.001	24.252	6	1.011	50.568	23			
2.002	24.252	6	1.012	54.180	23			

On-Line Controls (Pump)

US/PN	Volume (m <sup>3</sup> )	Ctrl MH Name	Invert (m)	Headloss (m)	Flow (m <sup>3</sup> /s)
1.015	0.040	23	77.300	0.20	0.0168
				0.40	0.0176
				0.60	0.0184
				0.80	0.0192
				1.00	0.0200
				1.40	0.0217
				1.80	0.0233
				2.20	0.0247
				2.60	0.0260
				3.00	0.0270

The Felin  
Bangor  
LL57 4LH

Client: Waste Go  
Project: King's Cliffe  
Title: N. Ditch Network



Date Jan-05  
File FSR REV J (09.09.05).SIM

Designed By JLM  
Checked By

Micro Drainage

Simulation W.9.5

Storage Pond at pipe 1.015 USMH

Storage Pond Invert Level (m) 78.250

Depth (m)	Area (m <sup>2</sup> )	Depth (m)	Area (m <sup>2</sup> )	Depth (m)	Area (m <sup>2</sup> )	Depth (m)	Area (m <sup>2</sup> )	Depth (m)	Area (m <sup>2</sup> )
0.0	147.0	2.4	658.6	4.8	658.6	7.2	658.6	9.6	658.6
0.4	227.0	2.8	658.6	5.2	658.6	7.6	658.6	10.0	658.6
0.8	327.4	3.2	658.6	5.6	658.6	8.0	658.6		
1.2	426.2	3.6	658.6	6.0	658.6	8.4	658.6		
1.6	536.6	4.0	658.6	6.4	658.6	8.8	658.6		
2.0	658.6	4.4	658.6	6.8	658.6	9.2	658.6		

## **APPENDIX C**

### **MICRODRAINAGE OUTPUT – SOUTHERN CATCHMENT**



The Felin  
Bangor  
LL57 4LH  
Date Apr-05  
File FSR REV J 5 X GF (07....

Client: Augean  
Project: King's Cliffe  
Title: Southern  
Designed By JM  
Checked By  
Simulation W.9.5



Network Details

\* - Indicates pipe has been modified outside of WinDes's Storm/Foul & Schedules

PN	Length (m)	Fall (m)	Slope (1:x)	Area (ha)	T.E. (mins)	Rain Pro	k (mm)	Hyd Sect	Dia (mm)
1.000	68.00	0.230	295.6	0.028	12.00	1	300.000	\\	32
1.001	50.00	0.170	294.1	0.021	0.00	1	300.000	\\	32
1.002	50.00	0.500	100.0	0.030	0.00	1	300.000	\\	32
1.003	50.00	0.300	166.7	0.028	0.00	1	300.000	\\	32
1.004	50.00	0.700	71.4	0.025	0.00	1	300.000	\\	32
1.005	50.00	0.150	333.3	0.026	0.00	1	300.000	\\	32
1.006	43.00	0.110	390.9	0.028	0.00	1	300.000	\\	32
1.007	58.00	0.150	386.7	0.041	0.00	1	300.000	\\	32
1.008	100.00	0.250	400.0	0.125	0.00	1	300.000	\\	32
1.009	101.00	0.260	388.4	0.048	0.00	1	300.000	\\	32
1.010	102.00	0.250	408.0	0.058	0.00	1	300.000	\\	32
1.011	100.00	0.350	285.7	0.076	0.00	1	300.000	\\	32
1.012	140.00	0.320	437.5	0.112	0.00	1	300.000	\\	32
1.013	127.00	0.860	147.7	0.135	0.00	1	300.000	\\	32
1.014	90.00	0.300	300.0	0.057	0.00	1	300.000	\\	32
1.015	80.00	1.000	80.0	0.049	0.00	1	300.000	\\	32
1.016	70.00	0.500	140.0	0.060	0.00	1	300.000	\\	32
1.017	100.00	0.250	400.0	0.078	0.00	1	300.000	\\	32
1.018	100.00	0.250	400.0	0.064	0.00	1	300.000	\\	32
1.019	100.00	0.250	400.0	0.037	0.00	1	300.000	\\	32
1.020	25.00	0.062	403.2	0.006	0.00	1	0.060	o	300
2.000	73.00	0.200	365.0	0.037	10.00	1	300.000	\\	32
2.001	51.00	0.130	392.3	0.029	0.00	1	300.000	\\	32
2.002	100.00	0.370	270.3	0.050	0.00	1	300.000	\\	32

PN	USMH No.	US/CL (m)	US/IL (m)	US/Dep (m)	DS/CL (m)	DS/IL (m)	DS/Dep (m)	Ctrl No.	US/MH (mm)
1.000	1	90.900	90.400	0.005	90.670	90.170	0.005		3000
1.001	4	90.670	90.170	0.005	90.500	90.000	0.005		3000
1.002	4	90.500	90.000	0.005	90.000	89.500	0.005		3000
1.003	4	90.000	89.500	0.005	89.700	89.200	0.005		3000
1.004	4	89.700	89.200	0.005	89.000	88.500	0.005		3000
1.005	4	89.000	88.500	0.005	88.850	88.350	0.005		3000
1.006	4	88.850	88.350	0.005	88.740	88.240	0.005		3000
1.007	4	88.740	88.240	0.005	88.590	88.090	0.005		3000
1.008	4	88.590	88.090	0.005	88.340	87.840	0.005		3000
1.009	4	88.340	87.840	0.005	88.080	87.580	0.005		3000
1.010	4	88.080	87.580	0.005	87.830	87.330	0.005		3000
1.011	4	87.830	87.330	0.005	87.480	86.980	0.005		3000
1.012	4	87.480	86.980	0.005	87.160	86.660	0.005		3000
1.013	4	87.160	86.660	0.005	86.300	85.800	0.005		3000
1.014	4	86.300	85.800	0.005	86.000	85.500	0.005		3000
1.015	4	86.000	85.500	0.005	85.000	84.500	0.005		3000
1.016	4	85.000	84.500	0.005	84.500	84.000	0.005		3000
1.017	4	84.500	84.000	0.005	84.300	83.750	0.055		3000
1.018	5	84.300	83.750	0.055	84.300	83.500	0.305		3000
1.019	6	84.300	83.500	0.305	84.500	83.250	0.755		3000
1.020	7	84.500	83.250	0.950	84.350	83.188	0.862		3000
2.000	8	90.700	90.200	0.005	90.500	90.000	0.005		3000
2.001	11	90.500	90.000	0.005	90.370	89.870	0.005		3000
2.002	11	90.370	89.870	0.005	90.000	89.500	0.005		3000



Egniol Limited  
 The Felin  
 Bangor  
 LL57 4LH  
 Date Apr-05  
 File FSR REV J 5 X GF (07....  
 Micro Drainage

Client: Augean  
 Project: King's Cliffe  
 Title: Southern  
 Designed By JM  
 Checked By  
 Simulation W.9.5



Network Details

PN	Length (m)	Fall (m)	Slope (1:x)	Area (ha)	T.E. (mins)	Rain Pro	k (mm)	Hyd Sect	Dia (mm)
2.003	70.00	0.600	116.7	0.045	0.00	1	300.000	∕∕	32
2.004	60.00	0.400	150.0	0.042	0.00	1	300.000	∕∕	32
2.005	93.00	1.500	62.0	0.048	0.00	1	300.000	∕∕	32
2.006	90.00	1.200	75.0	0.066	0.00	1	300.000	∕∕	32
2.007	115.00	0.200	575.0	0.059	0.00	1	300.000	∕∕	32
2.008	105.00	0.400	262.5	0.020	0.00	1	300.000	∕∕	32
3.000	62.00	0.500	124.0	0.028	9.50	1	300.000	∕∕	32
3.001	73.00	1.000	73.0	0.050	0.00	1	300.000	∕∕	32
3.002	81.00	0.700	115.7	0.068	0.00	1	300.000	∕∕	32
3.003	55.00	0.400	137.5	0.118	0.00	1	300.000	∕∕	32
3.004	105.00	1.100	95.5	0.201	0.00	1	300.000	∕∕	32
3.005	120.00	2.100	57.1	0.158	0.00	1	300.000	∕∕	32
2.009	80.00	0.400	200.0	0.055	0.00	1	300.000	∕∕	32
4.000	25.00	0.100	250.0	0.010	18.00	1	300.000	∕∕	32
4.001	15.00	0.050	300.0	0.009	0.00	1	300.000	∕∕	32
4.002	25.00	0.100	250.0	0.010	0.00	1	300.000	∕∕	32
4.003	120.00	3.300	36.4	0.015	0.00	1	300.000	∕∕	32
2.010	80.00	1.612	49.6	0.022	0.00	1	0.060	o	300
1.021	12.00	0.030	399.9	0.005	0.00	1	300.000	∕∕	32
5.000	50.00	0.300	166.7	0.028	18.00	1	300.000	∕∕	32

PN	USMH No.	US/CL (m)	US/IL (m)	US/Dep (m)	DS/CL (m)	DS/IL (m)	DS/Dep (m)	Ctrl No.	US/MH (mm)
2.003	11	90.000	89.500	0.005	89.400	88.900	0.005		3000
2.004	11	89.400	88.900	0.005	89.000	88.500	0.005		3000
2.005	11	89.000	88.500	0.005	87.500	87.000	0.005		3000
2.006	11	87.500	87.000	0.005	86.800	85.800	0.505		3000
2.007	11	86.800	85.800	0.505	86.600	85.600	0.505		3000
2.008	12	86.600	85.600	0.505	86.200	85.200	0.505		3000
3.000	13	91.500	91.000	0.005	91.000	90.500	0.005		3000
3.001	16	91.000	90.500	0.005	90.000	89.500	0.005		3000
3.002	16	90.000	89.500	0.005	89.300	88.800	0.005		3000
3.003	16	89.300	88.800	0.005	88.900	88.400	0.005		3000
3.004	16	88.900	88.400	0.005	87.800	87.300	0.005		3000
3.005	16	87.800	87.300	0.005	86.200	85.200	0.505		3000
2.009	17	86.200	85.200	0.505	85.800	84.800	0.505		3000
4.000	18	88.850	88.350	0.005	88.750	88.250	0.005		3000
4.001	19	88.750	88.250	0.005	88.700	88.200	0.005		3000
4.002	20	88.700	88.200	0.005	88.600	88.100	0.005		3000
4.003	21	88.600	88.100	0.005	85.800	84.800	0.505		3000
2.010	22	85.800	84.800	0.700	84.350	83.188	0.862		3000
1.021	23	84.350	83.188	0.667	84.350	83.158	0.697		3000
5.000	24	87.700	87.200	0.005	87.400	86.900	0.005		3000

The Felin  
Bangor  
LL57 4LH

Client: Augean  
Project: King's Cliffe  
Title: Southern

Date Apr-05

Designed By JM

File FSR REV J 5 X GF (07....

Checked By

Micro Drainage

Simulation W.9.5



Network Details

PN	Length (m)	Fall (m)	Slope (1:x)	Area (ha)	T.E. (mins)	Rain Pro	k (mm)	Hyd Sect	Dia (mm)
5.001	35.00	0.150	233.3	0.015	0.00	1	300.000	\/	32
5.002	125.00	3.592	34.8	0.018	0.00	1	0.060	o	300
1.022	12.00	0.030	400.0	0.099	0.00	1	0.060	o	300
6.000	70.00	0.200	350.0	0.034	18.00	1	300.000	\/	32
6.001	100.00	0.250	400.0	0.260	0.00	1	300.000	\/	32
1.023	10.00	0.105	95.2	0.000	0.00	1	0.060	o	225
1.024	200.00	7.000	28.6	0.000	0.00	1	0.060	o	225
1.025	250.00	8.750	28.6	0.000	0.00	1	0.060	o	225

PN	USMH No.	US/CL (m)	US/IL (m)	US/Dep (m)	DS/CL (m)	DS/IL (m)	DS/Dep (m)	Ctrl No.	US/MH (mm)
5.001	25	87.400	86.900	0.005	87.250	86.750	0.005		3000
5.002	26	87.250	86.750	0.200	84.350	83.158	0.892		3000
1.022	27	84.350	83.158	0.892	84.350	83.128	0.922		3000
6.000	28	84.800	84.300	0.005	84.600	84.100	0.005		3000
6.001	29	84.600	84.100	0.005	84.350	83.850	0.005		3000
1.023	30	84.350	82.500	1.625	84.000	82.395	1.380	1	3000
1.024	31	84.000	82.395	1.380	77.600	75.395	1.980		3000
1.025	32	77.600	75.395	1.980	84.000	66.645	17.130		1500

The Felin  
Bangor  
LL57 4LH

Client: Augean  
Project: King's Cliffe  
Title: Southern



Date Apr-05  
File FSR REV J 5 X GF (07....

Designed By JM  
Checked By

Micro Drainage

Simulation W.9.5

On-Line Controls (Orifice)

US/PN	Volume (m <sup>3</sup> )	Ctrl MH Name	Invert (m)	Dia (m)	Coef of Contraction
1.022	0.636	30	82.500	0.148	0.600
6.001	50.052	30	82.500	0.148	0.600

The Felin  
Bangor  
LL57 4LH

Client: Augean  
Project: King's Cliffe  
Title: Southern



Date Apr-05

Designed By JM

File FSR REV J 5 X GF (07....)

Checked By

Micro Drainage

Simulation W.9.5

Storage Pond at pipe 1.023 USMH 30

Storage Pond Invert Level (m) 82.500

Depth (m)	Area (m <sup>2</sup> )	Depth (m)	Area (m <sup>2</sup> )	Depth (m)	Area (m <sup>2</sup> )	Depth (m)	Area (m <sup>2</sup> )	Depth (m)	Area (m <sup>2</sup> )
0.0	469.6	2.4	1225.4	4.8	1225.4	7.2	1225.4	9.6	1225.4
0.4	598.4	2.8	1225.4	5.2	1225.4	7.6	1225.4	10.0	1225.4
0.8	740.3	3.2	1225.4	5.6	1225.4	8.0	1225.4		
1.2	892.6	3.6	1225.4	6.0	1225.4	8.4	1225.4		
1.6	1054.3	4.0	1225.4	6.4	1225.4	8.8	1225.4		
2.0	1225.4	4.4	1225.4	6.8	1225.4	9.2	1225.4		

**APPENDIX D**

**FLOOD ANALYSIS OF HIGHWAY CULVERT**

Calculation Sheet



Client: Augeon	Job No: 1821	Project: King's Highway 14
-------------------	-----------------	-------------------------------

Made by: J.M.H.	Date: 15/08/08	Checked by: J.M.	Date:	Sheet No: F-1
--------------------	-------------------	---------------------	-------	------------------

Highway culvert

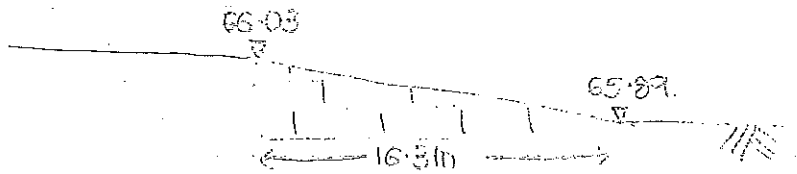
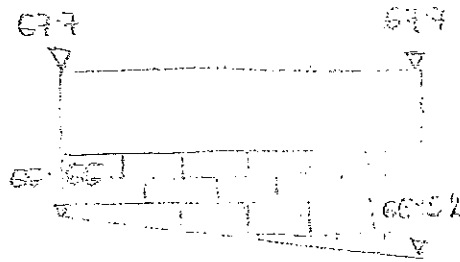

$$S = (66.03 - 65.89) / 16.3 = 0.0086$$

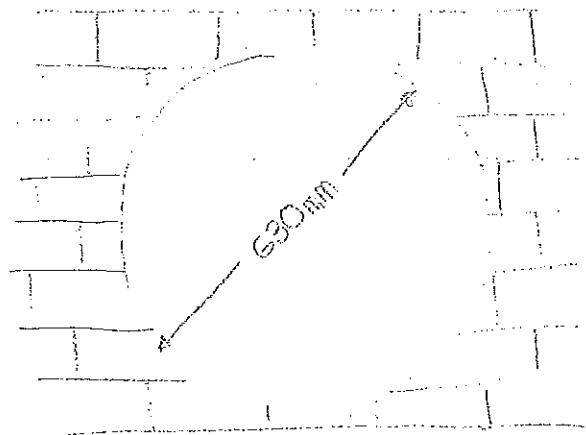

Levels taken from Dug No. 1821 31714

Client: Augean

Job: King's Cliffe SWM

Title: Table 1 - Hydraulic Analysis of Highway culvert

Manning's equation,  $Q = A/n R^{2/3} S^{1/2}$

Condition of Highway culvert	d m	A m <sup>2</sup>	P m	R	S	k <sub>s</sub> mm	n	Q m <sup>3</sup> /s	% blocked	Q max m <sup>3</sup> /s	Q max l/s
well pointed brickwork (good), 0 % blocked	0.63	0.3117	1.9792	0.1575	0.0086	1.5	0.0127	0.6627	0	0.6627	663
well pointed brickwork (normal), 0 % blocked	0.63	0.3117	1.9792	0.1575	0.0086	3.0	0.0145	0.5826	0	0.5826	583
well pointed brickwork (poor), 0 % blocked	0.63	0.3117	1.9792	0.1575	0.0086	6.0	0.0161	0.5229	0	0.5229	523
old, in need of pointing (normal), 0 % blocked	0.63	0.3117	1.9792	0.1575	0.0086	15.0	0.0178	0.4727	0	0.4727	473
old, in need of pointing (poor), 0 % blocked	0.63	0.3117	1.9792	0.1575	0.0086	30.0	0.0207	0.4076	0	0.4076	408
well pointed brickwork (good), 25 % blocked	0.63	0.3117	1.9792	0.1575	0.0086	1.5	0.0127	0.6627	25	0.4970	497
well pointed brickwork (normal), 25 % blocked	0.63	0.3117	1.9792	0.1575	0.0086	3.0	0.0145	0.5826	25	0.4370	437
well pointed brickwork (poor), 25 % blocked	0.63	0.3117	1.9792	0.1575	0.0086	6.0	0.0161	0.5229	25	0.3922	392
old, in need of pointing (normal), 25 % blocked	0.63	0.3117	1.9792	0.1575	0.0086	15.0	0.0178	0.4727	25	0.3546	355
old, in need of pointing (poor), 25 % blocked	0.63	0.3117	1.9792	0.1575	0.0086	30.0	0.0207	0.4076	25	0.3057	306
well pointed brickwork (good), 50 % blocked	0.63	0.3117	1.9792	0.1575	0.0086	1.5	0.0127	0.6627	50	0.3313	331
well pointed brickwork (normal), 50 % blocked	0.63	0.3117	1.9792	0.1575	0.0086	3.0	0.0145	0.5826	50	0.2913	291
well pointed brickwork (poor), 50 % blocked	0.63	0.3117	1.9792	0.1575	0.0086	6.0	0.0161	0.5229	50	0.2614	261
old, in need of pointing (normal), 50 % blocked	0.63	0.3117	1.9792	0.1575	0.0086	15.0	0.0178	0.4727	50	0.2364	236
old, in need of pointing (poor), 50 % blocked	0.63	0.3117	1.9792	0.1575	0.0086	30.0	0.0207	0.4076	50	0.2038	204
well pointed brickwork (good), 75 % blocked	0.63	0.3117	1.9792	0.1575	0.0086	1.5	0.0127	0.6627	75	0.1657	166
well pointed brickwork (normal), 75 % blocked	0.63	0.3117	1.9792	0.1575	0.0086	3.0	0.0145	0.5826	75	0.1457	146
well pointed brickwork (poor), 75 % blocked	0.63	0.3117	1.9792	0.1575	0.0086	6.0	0.0161	0.5229	75	0.1307	131
old, in need of pointing (normal), 75 % blocked	0.63	0.3117	1.9792	0.1575	0.0086	15.0	0.0178	0.4727	75	0.1182	118
old, in need of pointing (poor), 75 % blocked	0.63	0.3117	1.9792	0.1575	0.0086	30.0	0.0207	0.4076	75	0.1019	102

d diameter

A cross sectional area

P wetted perimeter

R hydraulic radius

S slope

k<sub>s</sub> Nikuradse equivalent sand roughness size

n Manning's roughness coefficient

Client: Augean

Job: King's Cliffe SWM

Title: Table 2 - Unit Hydrograph at Highway culvert – Flow from field

**Unit Hydrograph Calculator**

Unit Hydrograph

FSR Input      FEH Input      Results Graph

FSR - Method

Region	England and Wales	Main Channel Length (m)	1038.000	CWI	82.600
M5-60	20.000	H(85%) (m)	79.500	Urban	0.000
Ratio R	0.420	H(10%) (m)	69.000	SFR	10.000
		Area (ha)	79.000	LAG (hrs)	0.000
Areal Reduction Factor	1.000	SAAR (mm)	580		

Calculate

**Unit Hydrograph Calculator**

Unit Hydrograph

FSR Input      FEH Input      Results Graph

Results

TPD (mins)	234
T <sub>i</sub> (mins)	24
TPt (mins)	246
QP (m <sup>3</sup> /s 10mm)	0.425
TB (mins)	619
Base Flow (m <sup>3</sup> /s)	0.003
PR (%)	0.000
S1085 (m/km)	13.487

Unit Hydrograph for 1 year return period 120 minutes storm

The graph shows a unit hydrograph for a 1-year return period 120-minute storm. The y-axis is Peak (m³/h) ranging from 0.0000 to 0.0300. The x-axis is Time (mins) ranging from 0 to 619. The hydrograph shows a sharp rise to a constant peak of approximately 0.027 m³/h at 24 minutes, which remains constant until 246 minutes, after which it begins to decline.



Client: Augean

Job: King's Cliffe SWM

Title: Table 3 - Unit Hydrograph at Highway culvert – Flow from Highway to North

**Unit Hydrograph Calculator**

Unit Hydrograph

FSR Input      FEH Input      Results Graph

**FSR - Method**

Region	England and Wales	Main Channel Length (m)	600.000	CWI	82.600
M5-60	20.000	H(85%) (m)	82.000	Urban	0.660
Ratio R	0.420	H(10%) (m)	68.000	SPR	10.000
		Area (ha)	0.154	LAG (hrs)	0.000
Areal Reduction Factor	1.000	SAAR (mm)	580		

Calculate

**Unit Hydrograph Calculator**

Unit Hydrograph

FSR Input      FEH Input      Results Graph

**Results**

TPO (mins)	25
T (mins)	4
TPt (mins)	27
QF (m <sup>3</sup> /s 10mm)	0.008
TB (mins)	68
Base Flow (m <sup>3</sup> /s)	0.000
PR (%)	13.379
S1085 (m/km)	31.111

Unit Hydrograph for 1 year return period 120 minutes storm

Flow (m<sup>3</sup>/s)

Time (mins)

Client: Augean

Job: King's Cliffe SWM

Title: Table 4 - Unit Hydrograph at Highway culvert – Flow from Highway to South

**Unit Hydrograph Calculator**

Unit Hydrograph

FSR Input      FEH Input      Results Graph

**FSR - Method**

Region	England and Wales	Main Channel Length (m)	310.000	CWI	82.600	
M5-60	20.000	Msp	H(85%) (m)	71.500	Urban	0.660
Ratio R	0.420		H(10%) (m)	68.000	SPR	10.000
		Area (ha)	0.080	LAG (hrs)	0.000	
Areal Reduction Factor	1.000	SAAR (mm)	580			

Calculate

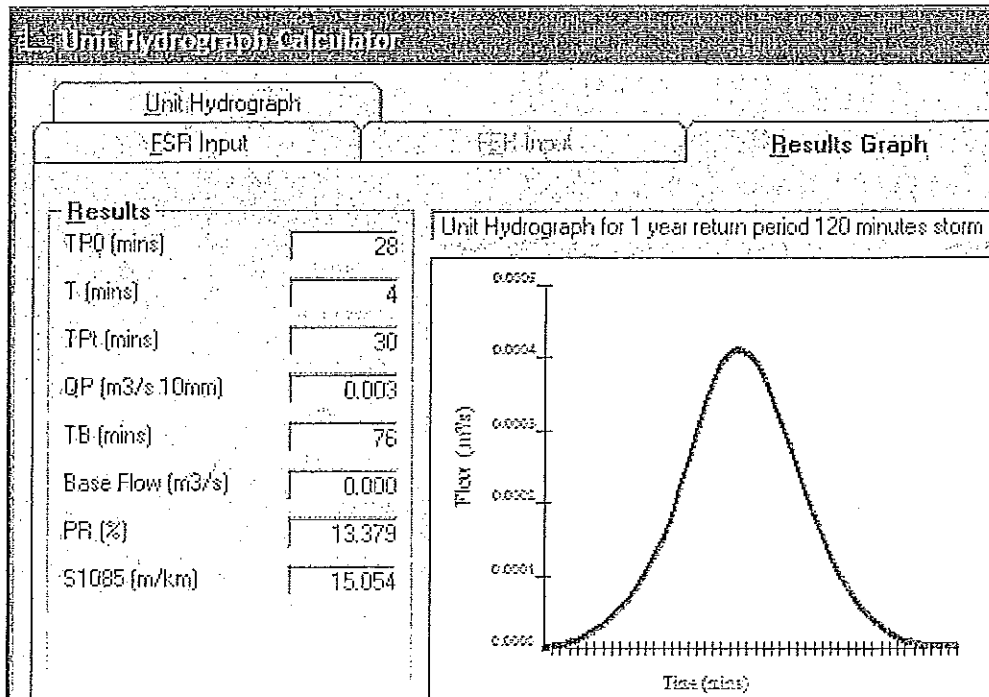

# Calculation Sheet



Client: Augean	Job No: 1521	Project: Kings Cliffs SWMA		
Made by: J. Mills	Date: 9/01/06	Checked by:	Date:	Sheet No: H1 BVA

Assessment of the most significant area contributing to highway culvert flow

SE Discharge consent =  $5 \times \text{GFR} = 50 \text{ c/s}$

Return Period		1	5	10	30	50	100
Max. outflow	SE pond (2.000)	33 <small>240 Win.</small>	39 <small>240 Win.</small>	42 <small>240 Win.</small>	45 <small>240 Win.</small>	47 <small>240 Win.</small>	50 <small>240 Win.</small>
	Field (1.000)	3 <small>15 Sum.</small>	8 <small>1440 Sum.</small>	21 <small>1440 Sum.</small>	49 <small>1440 Sum.</small>	66 <small>1440 Sum.</small>	94 <small>1440 Sum.</small>
	Highway (3.000 + 4.000)	1 <small>60 Sum.</small>	3 <small>60 Sum.</small>	3 <small>60 Sum.</small>	3 <small>60 Sum.</small>	4 <small>60 Sum.</small>	5 <small>60 Sum.</small>
Critical area.		SE pond	SE pond	SE pond	Field	Field	Field
Highway culvert (1.00%)	critical storm.	240 Win.	240 Win.	240 Win.	1440 Sum.	1440 Sum.	1440 Sum.
	Max. outflow.	34	42	45	86	105	138

( ) = MicroDrainage Reference No

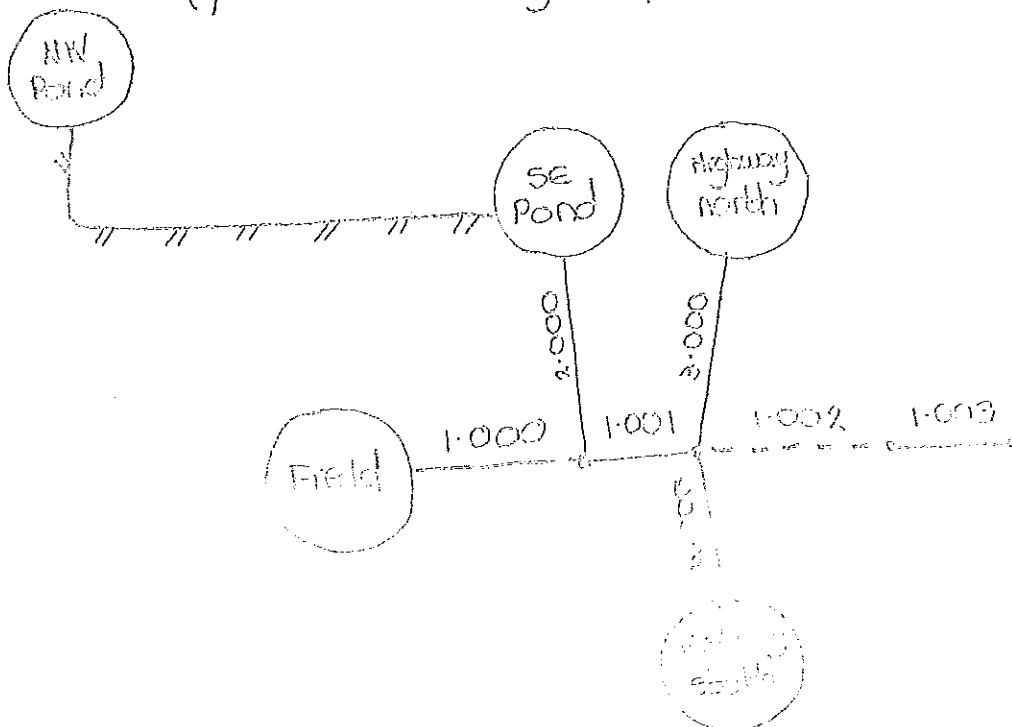

## **APPENDIX E**

### **MICRODRAINAGE OUTPUT - FLOOD ANALYSIS OF HIGHWAY CULVERT**

Egniol Limited		Page 1
The Felin Bangor LL57 4LH	Client: Augean Job: King's Cliffe SWM Title: Flow in culvert	
Date Jan-06 File 10.01.06, 1 yr RP, 240...	Designed By JLM Checked By	
Micro Drainage	Simulation W.9.5	

Summary of Results

Return Period (year)	1	Analysis Time Step	Fine
Storm Duration (mins)	240	DVD Status	OFF
Profile Type	Winter	Inertia Status	OFF
Margin for Flood Risk warning (mm)	200		

PN	Water Lev. (m)	Surcharged Depth (m)	Flooded Vol (m <sup>3</sup> )	Flow/ Capacity	Overflow (l/s)	Pipe Flow (l/s)	Status
1.000	74.052	-0.443	0.000	0.00	0	3	O K
2.000	67.631	-0.154	0.000	0.22	0	31	O K
1.001	66.651	-0.404	0.000	0.03	0	34	O K
3.000	66.290	-0.485	0.000	0.00	0	1	O K
4.000	66.726	-0.489	0.000	0.00	0	0	O K
1.002	66.127	-0.533	0.000	0.08	0	34	O K

The Felin  
Bangor  
LL57 4LH

Client: Augean  
Job: King's Cliffe SWM  
Title: Flow in culvert



Date Jan-06  
File 10.01.06, 5 yr RP, 240...

Designed By JLM  
Checked By

Micro Drainage

Simulation W.9.5

Summary of Results

Return Period (years)	5	Analysis Time Step	Fine
Storm Duration (mins)	240	DVD Status	OFF
Profile Type	Winter	Inertia Status	OFF
Margin for Flood Risk warning (mm)	200		

EN	Water Lev. (m)	Surcharged Depth (m)	Flooded Vol (m³)	Flow/ Capacity	Overflow (l/s)	Pipe Flow (l/s)	Status
1.000	74.052	-0.443	0.000	0.00	0	3	O K
2.000	67.640	-0.145	0.000	0.28	0	39	O K
1.001	66.660	-0.395	0.000	0.03	0	42	O K
3.000	66.295	-0.480	0.000	0.00	0	1	O K
4.000	66.730	-0.485	0.000	0.00	0	0	O K
1.002	66.138	-0.522	0.000	0.10	0	42	O K

Egniol Limited		Page 1
The Felin Bangor LL57 4LH	Client: Augean Job: King's Cliffe SWM Title: Flow in culvert	
Date Jan-06 File 10.01.06, 10 yr RP, 24...	Designed By JLM Checked By	
Micro Drainage	Simulation W.9.5	

Summary of Results

Return Period (years)	10	Analysis Time Step	Fine
Storm Duration (mins)	240	DVD Status	OFF
Profile Type	Winter	Inertia Status	OFF
Margin for Flood Risk warning (mm)	200		

PN	Water Lev. (m)	Surcharged Depth (m)	Flooded Vol (m³)	Flow/ Capacity	Overflow (1/s)	Pipe Flow (1/s)	Status
1.000	74.052	-0.443	0.000	0.00	0	3	O K
2.000	67.644	-0.141	0.000	0.30	0	42	O K
1.001	66.663	-0.392	0.000	0.03	0	45	O K
3.000	66.297	-0.478	0.000	0.00	0	1	O K
4.000	66.731	-0.484	0.000	0.00	0	1	O K
1.002	66.142	-0.518	0.000	0.11	0	45	O K

Egniol Limited		Page 1
The Felin Bangor LL57 4LH	Client: Augean Job: King's Cliffe SWM Title: Flow in culvert	
Date Jan-06 File 10.01.06, 30 yr RP, 14...	Designed By JLM Checked By	
Micro Drainage	Simulation W.9.5	

Summary of Results

Return Period (years)	30	Analysis Time Step	Fine
Storm Duration (mins)	1440	DVD Status	OFF
Profile Type	Summer	Inertia Status	OFF
Margin for Flood Risk warning (mm)	200		

PN	Water Lev. (m)	Surcharged Depth (m)	Flooded Vol (m³)	Flow/ Capacity	Overflow (l/s)	Pipe Flow (l/s)	Status
1.000	74.171	-0.324	0.000	0.08	0	49	O K
2.000	67.640	-0.145	0.000	0.28	0	39	O K
1.001	66.707	-0.348	0.000	0.06	0	86	O K
3.000	66.290	-0.485	0.000	0.00	0	1	O K
4.000	66.727	-0.488	0.000	0.00	0	0	O K
1.002	66.191	-0.469	0.000	0.21	0	86	O K



The Felin  
Bangor  
LL57 4LH

Client: Augean  
Job: King's Cliffe SWM  
Title: Flow in culvert



Date Jan-06  
File 10.01.06, 50 yr RP, 14...

Designed By JLM  
Checked By

Micro Drainage

Simulation W.9.5

Summary of Results

Return Period (years) 50 Analysis Time Step Fine  
Storm Duration (mins) 1440 DVD Status OFF  
Profile Type Summer Inertia Status OFF  
Margin for Flood Risk warning (mm) 200

PN	Water Lev. (m)	Surcharged Depth (m)	Flooded Vol (m <sup>3</sup> )	Flow/ Capacity	Overflow (l/s)	Pipe Flow (l/s)	Status
1.000	74.194	-0.301	0.000	0.11	0	66	O K
2.000	67.642	-0.143	0.000	0.29	0	41	O K
1.001	66.719	-0.336	0.000	0.08	0	105	O K
3.000	66.292	-0.483	0.000	0.00	0	1	O K
4.000	66.728	-0.487	0.000	0.00	0	0	O K
1.002	66.214	-0.446	0.000	0.25	0	105	O K

The Felin  
Bangor  
LL57 4LH

Client: Augean  
Job: King's Cliffe SWM  
Title: Flow from field

Date Jan-06  
File 10.01.06, 50 yr RP, 14...

Designed By JLM  
Checked By



Micro Drainage

Simulation W.9.5

Graphs for Pipe 1.000 USMH Number 2  
Storm Duration 1440 mins (Summer) Return Period 50 years  
Status : OK

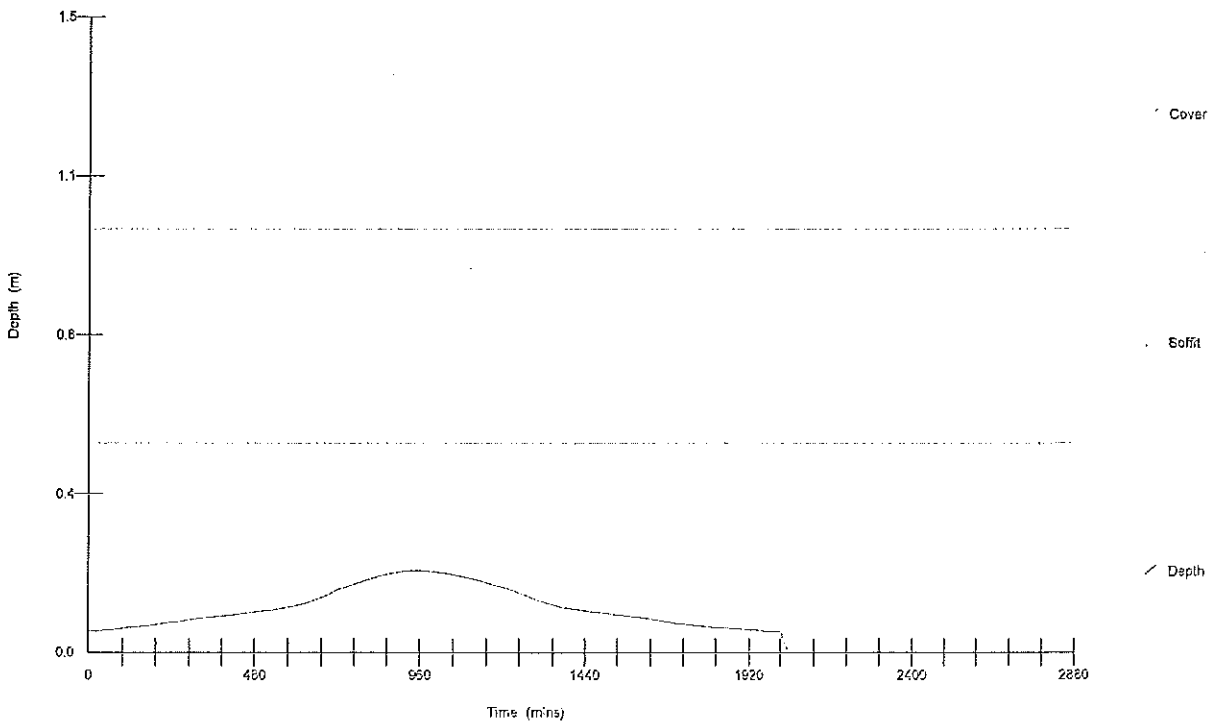
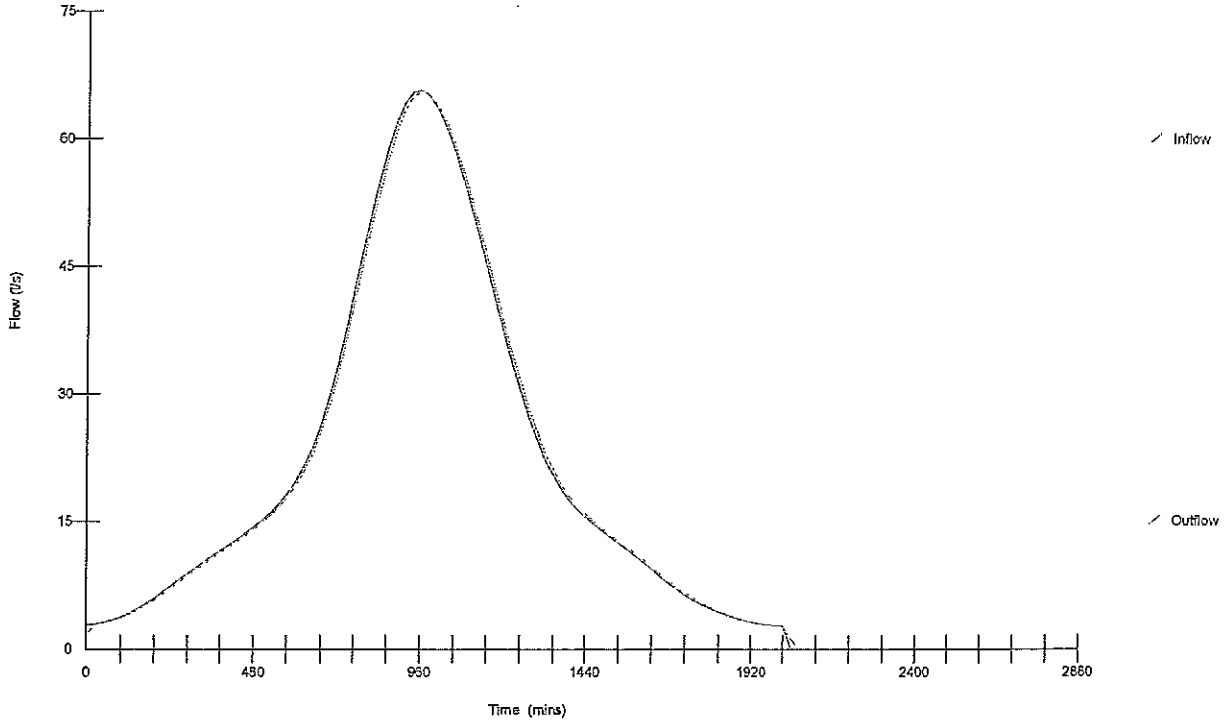

The Felin  
Bangor  
LL57 4LM  
Date Jan-06  
File 10.01.06, 50 yr RP, 14...

Client: Augean  
Job: King's Cliffe SWM  
Title: Flow from SE pond  
Designed By JLM  
Checked By  
Simulation W.9.5



Graphs for Pipe 2.000 USMH Number  
Storm Duration 1440 mins (Summer) Return Period 50 years  
Status : OK

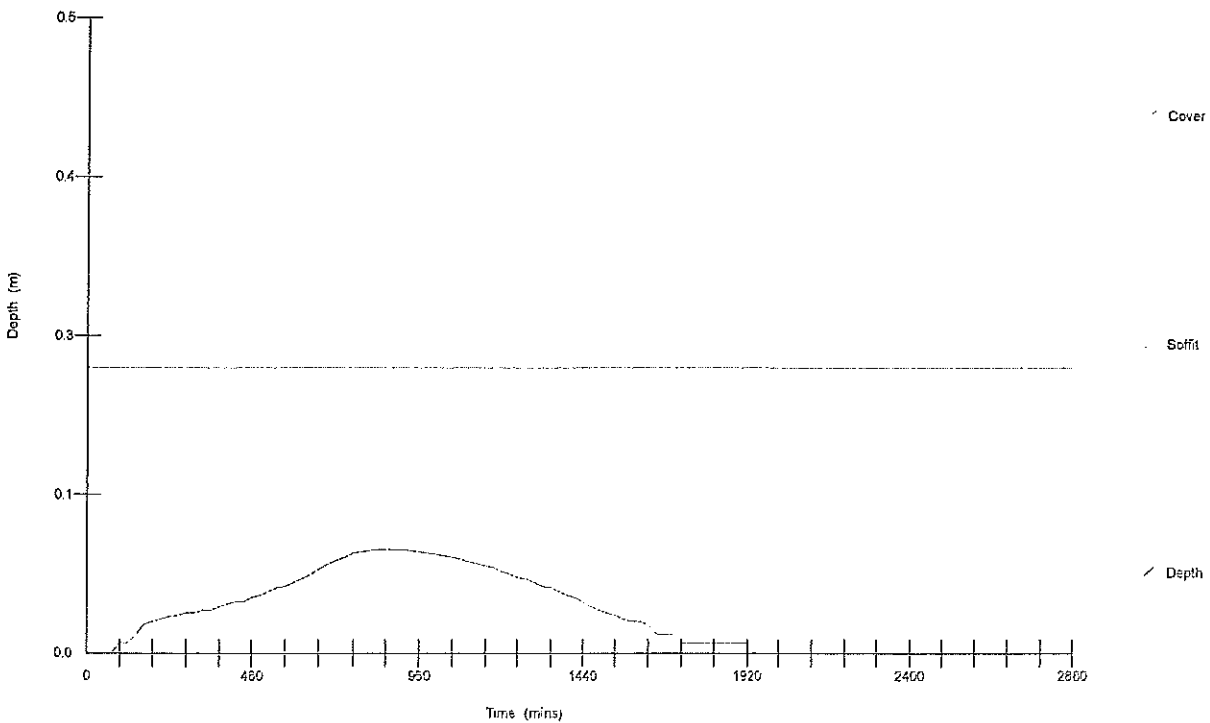
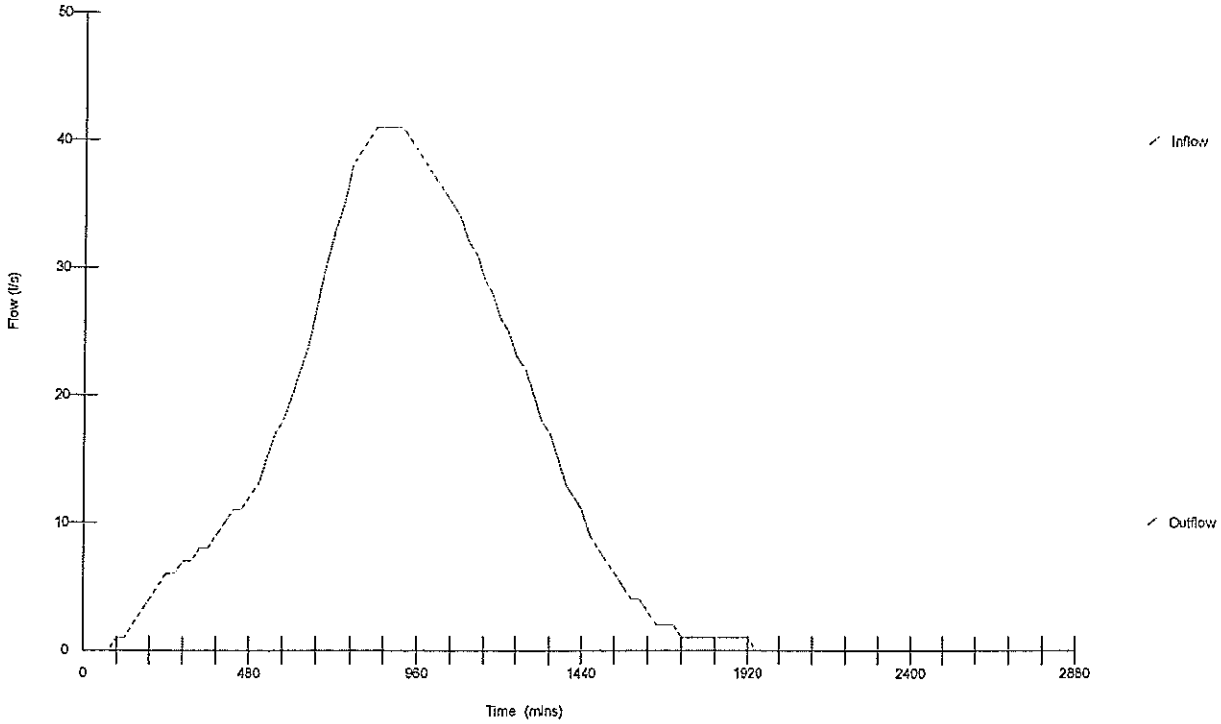

The Felin  
Bangór  
LL57 4LH

Client: Augean  
Job: King's Cliffe SWM  
Title: Flow from road N

Date Jan-06  
File 10.01.06, 50 yr RP, 14...

Designed By JLM  
Checked By



Micro Drainage

Simulation W.9.5

Graphs for Pipe 3.000 USMH Number 3  
Storm Duration 1440 mins (Summer) Return Period 50 years  
Status : OK

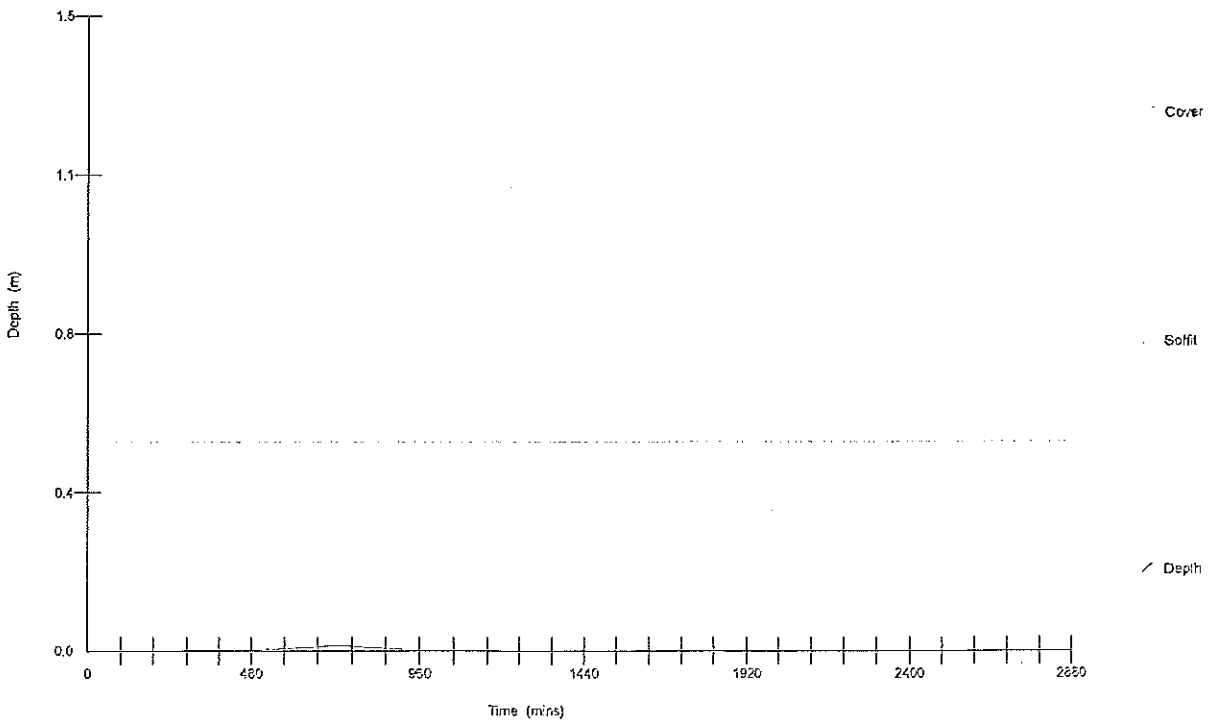
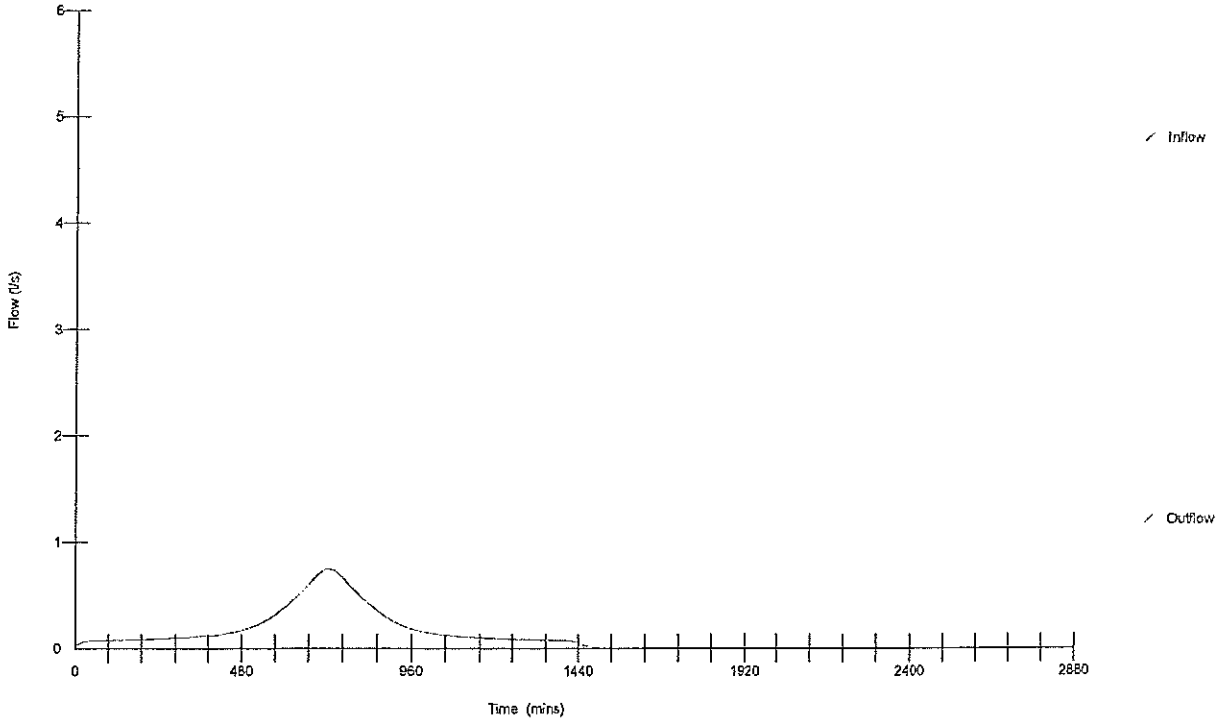

The Felin  
Bangor  
LL57 4LH

Client: Augean  
Job: King's Cliffe SWM  
Title: Flow from road S

Date Jan-06  
File 10.01.06, 50 yr RP, 14...

Designed By JLM  
Checked By



Micro Drainage

Simulation W.9.5

Graphs for Pipe 4.000 USMH Number 3  
Storm Duration 1440 mins (Summer) Return Period 50 years  
Status : OK

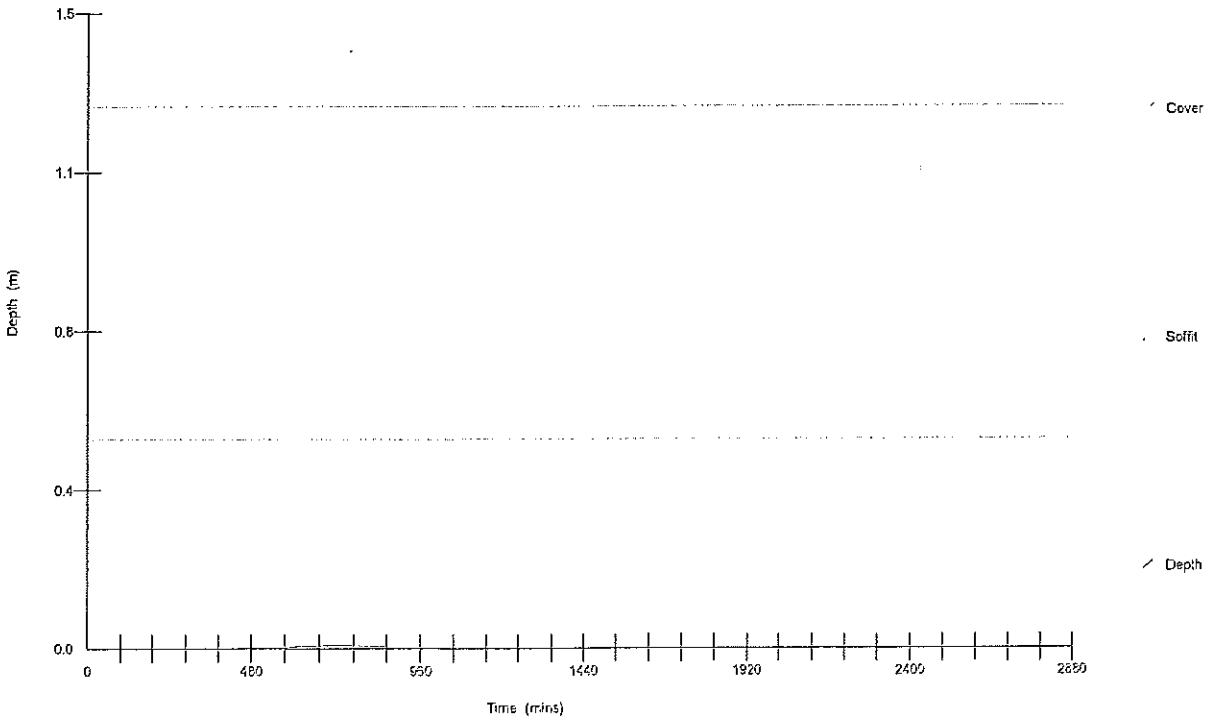
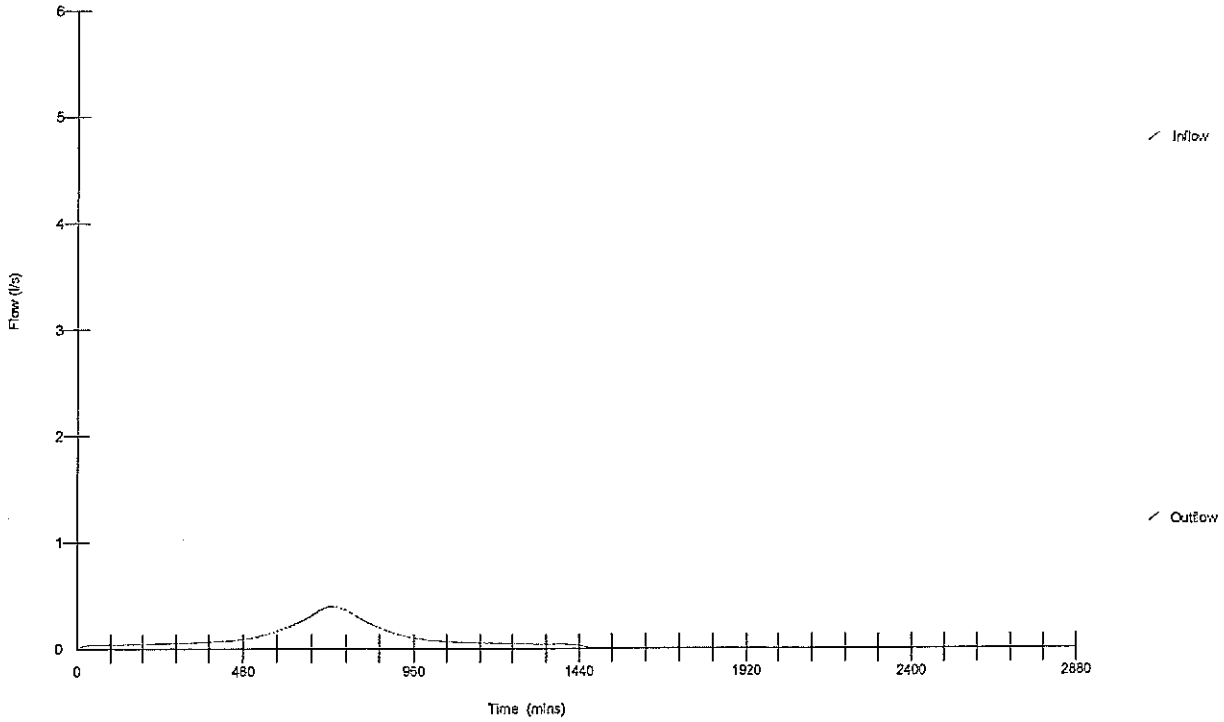

The Felin  
Bangor  
LL57 4LH

Client: Augean  
Job: King's Cliffe SWM  
Title: Flow in culvert



Date Jan-06

Designed By JLM

File 10.01.06, 50 yr RP, 14...

Checked By

Micro Drainage

Simulation W.9.5

Graphs for Pipe 1.002 USMH Number 3  
Storm Duration 1440 mins (Summer) Return Period 50 years  
Status : OK

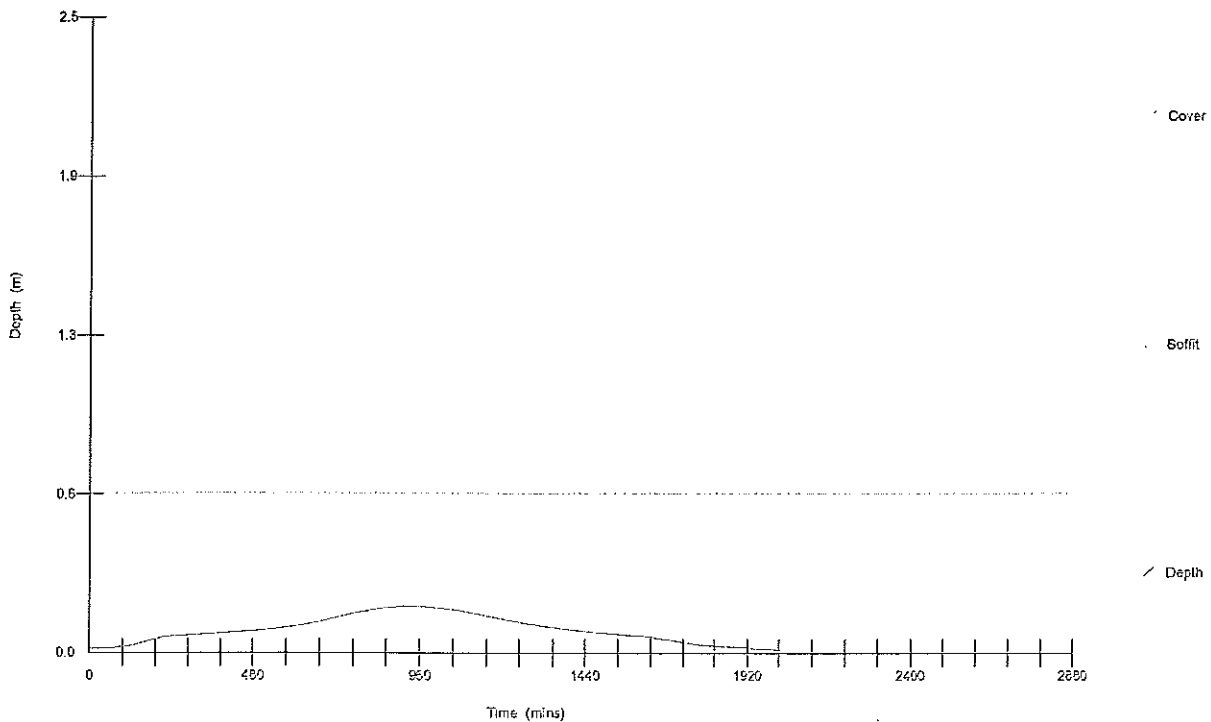
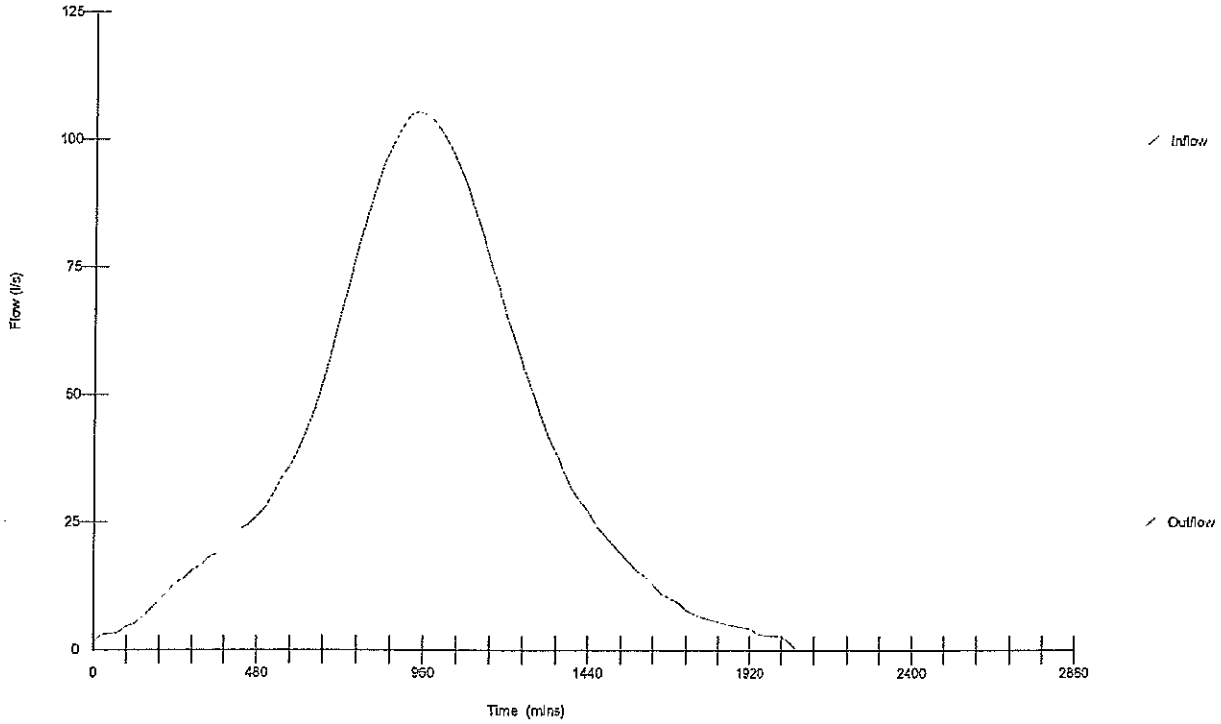

The Felin  
Bangor  
LL57 4LH

Client: Augean  
Job: King's Cliffe SWM  
Title: Flow in culvert



Date Jan-06

Designed By JLM

File 10.01.06, 100 yr RP, 1...

Checked By

Micro Drainage

Simulation W.9.5

### Summary of Results

Return Period (years)	100	Analysis Time Step	Fine
Storm Duration (mins)	1440	DVD Status	OFF
Profile Type	Summer	Inertia Status	OFF
Margin for Flood Risk warning (mm)	200		

PN	Water Lev. (m)	Surcharged Depth (m)	Flooded Vol (m <sup>3</sup> )	Flow/ Capacity	Overflow (l/s)	Pipe Flow (l/s)	Status
1.000	74.230	-0.265	0.000	0.16	0	94	O K
2.000	67.646	-0.139	0.000	0.31	0	44	O K
1.001	66.737	-0.318	0.000	0.10	0	137	O K
3.000	66.294	-0.481	0.000	0.00	0	1	O K
4.000	66.729	-0.486	0.000	0.00	0	0	O K
1.002	66.243	-0.417	0.000	0.33	0	138	O K

The Felin  
 Bångör  
 LL57 4LH  
 Date Jan-06  
 File 10.01.06, 100 yr RP, 1...

Client: Augean  
 Job: King's Cliffe SWM  
 Title: Flow from field  
 Designed By JLM  
 Checked By  
 Simulation W.9.5



Graphs for Pipe 1.000 USMH Number 2  
 Storm Duration 1440 mins (Summer) Return Period 100 years  
 Status : OK

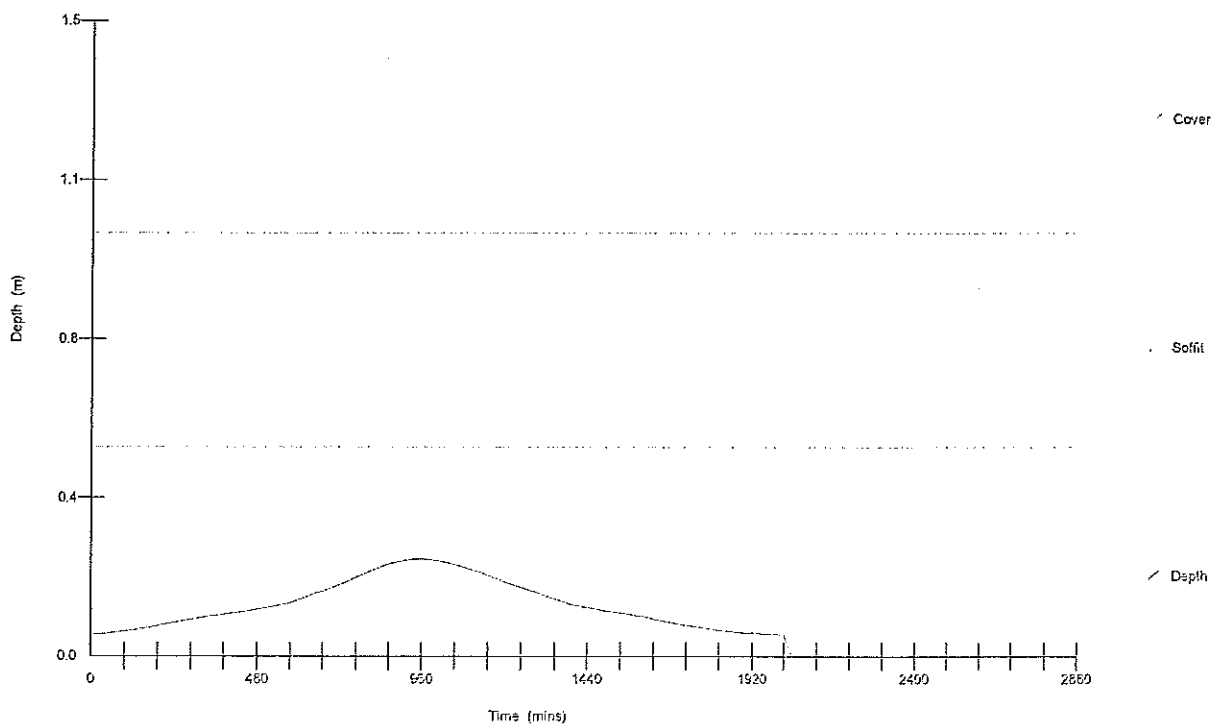
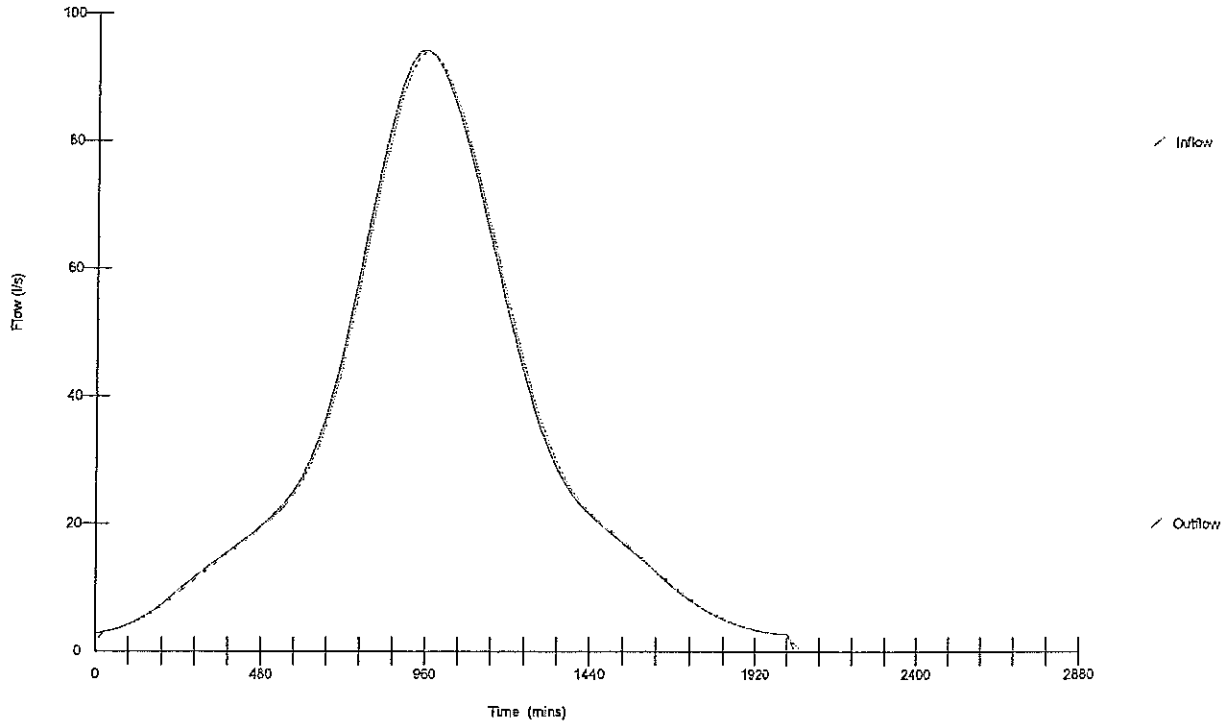



The Felin  
Bangor  
LL57 4LH  
Date Jan-06  
File 10.01.06, 100 yr RP, 1...

Client: Augean  
Job: King's Cliffe SWM  
Title: Flow from SE pond  
Designed By JLM  
Checked By  
Simulation W.9.5



Graphs for Pipe 2.000 USMH Number  
Storm Duration 1440 mins (Summer) Return Period 100 years  
Status : OK

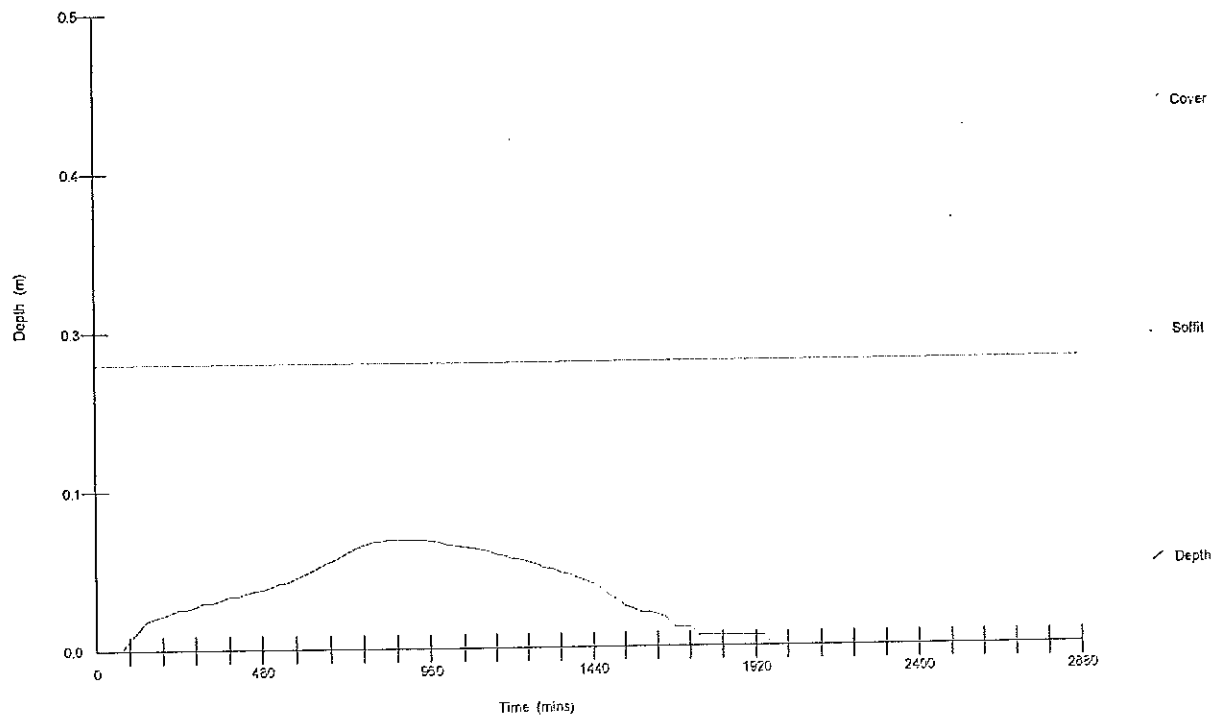
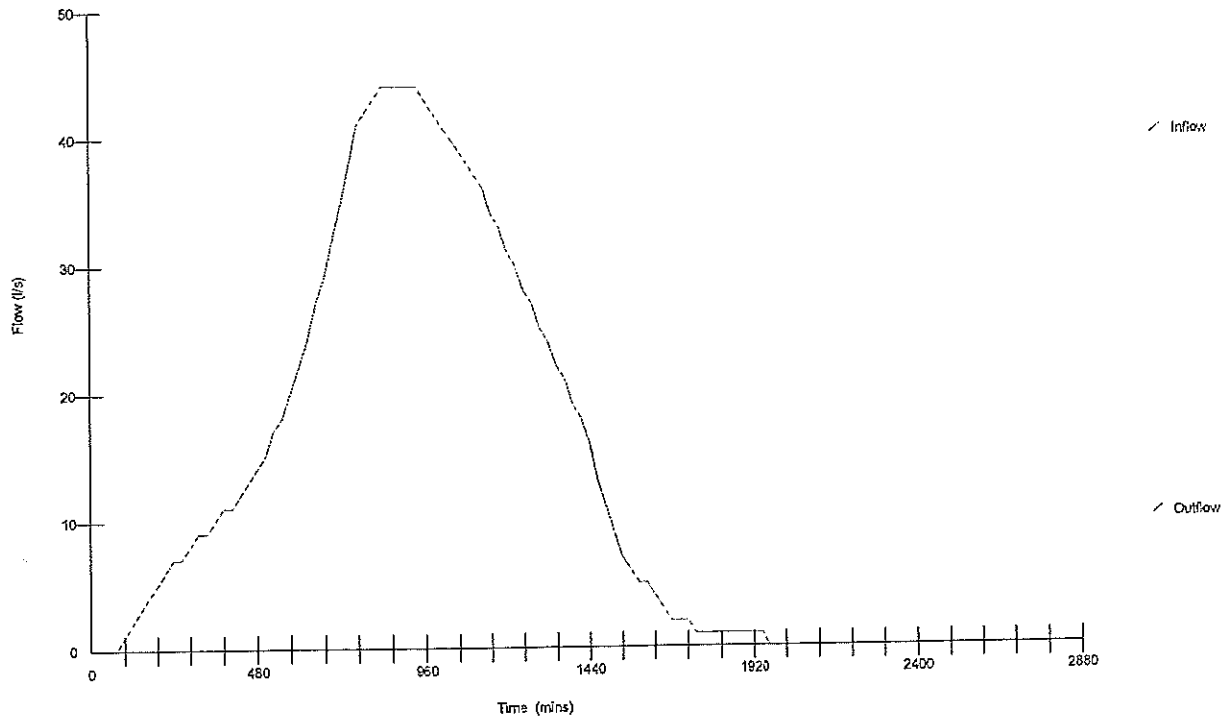

The Felin  
Bangor  
LL57 4LH

Client: Augean  
Job: King's Cliffe SWM  
Title: Flow from road N

Date Jan-06  
File 10.01.06, 100 yr RP, 1...

Designed By JLM  
Checked By

Micro Drainage

Simulation W.9.5



Graphs for Pipe 3.000 USMH Number 3  
Storm Duration 1440 mins (Summer) Return Period 100 years  
Status : OK

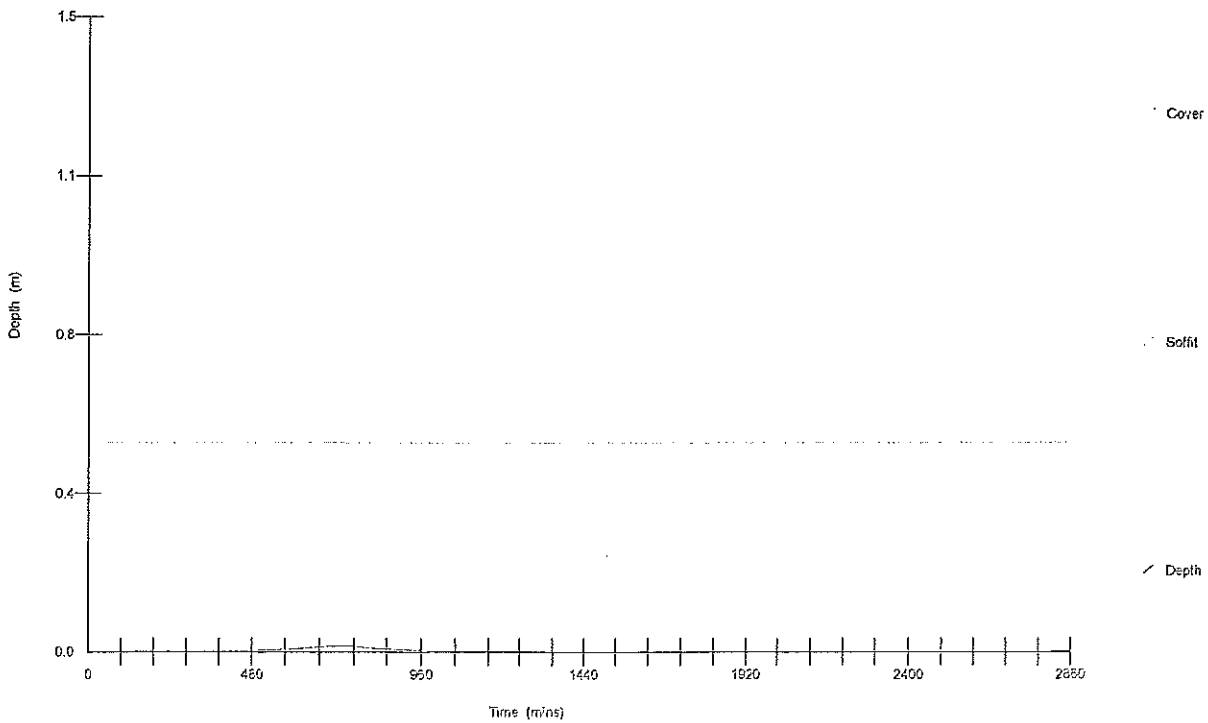
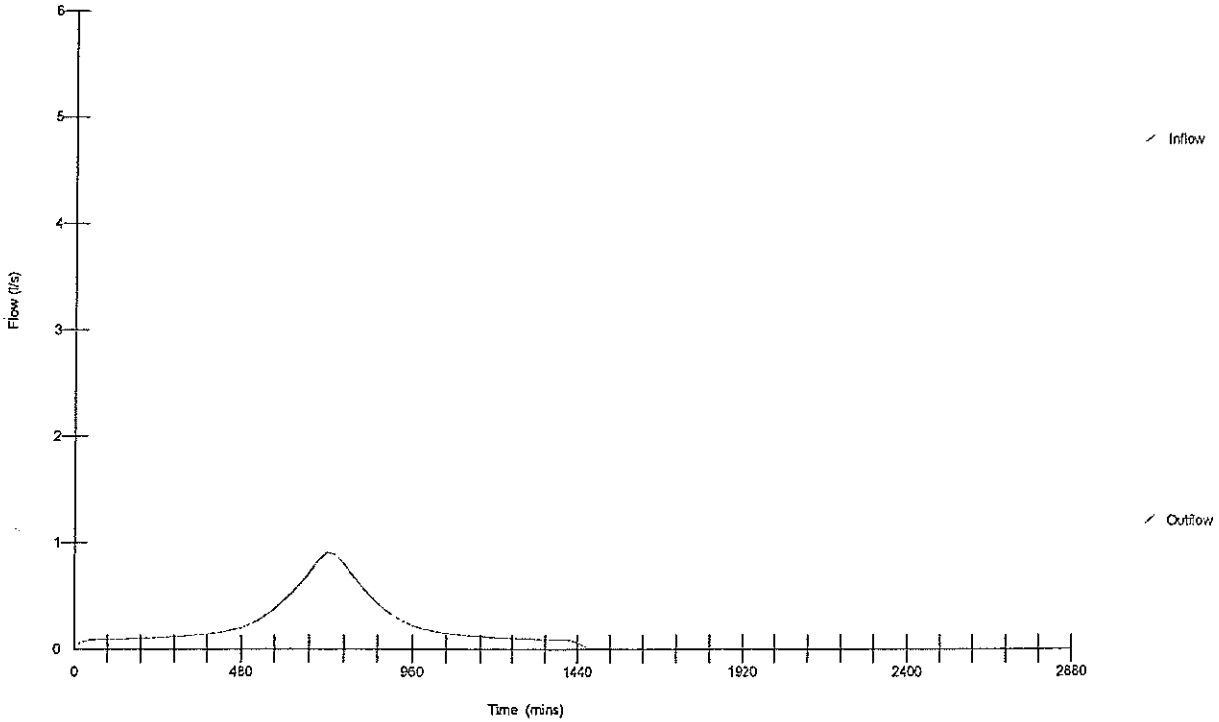

The Felin  
Bangor  
LL57 4LH

Client: Augean  
Job: King's Cliffe SWM  
Title: Flow from road S

Date Jan-06  
File 10.01.06, 100 yr RP, 1...

Designed By JLM  
Checked By



Micro Drainage

Simulation W.9.5

Graphs for Pipe 4.000 USMH Number 3  
Storm Duration 1440 mins (Summer) Return Period 100 years  
Status : OK

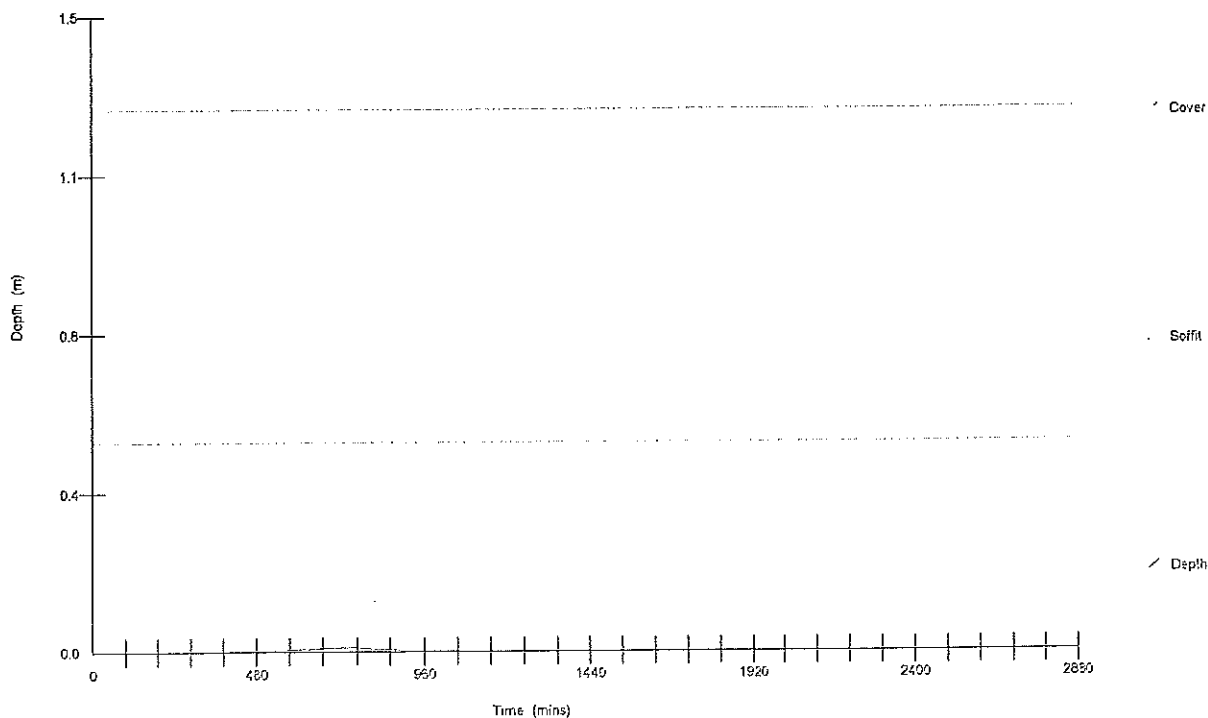
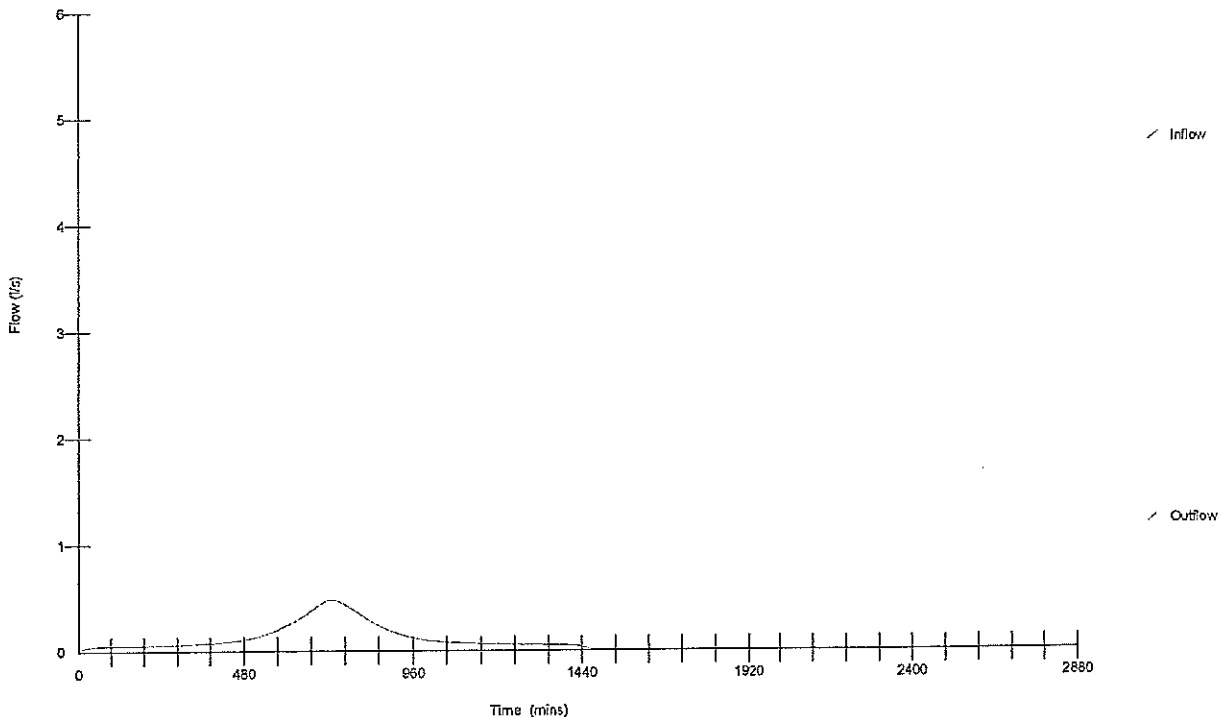

The Felin  
Bangor  
LL57 4LH

Client: Augean  
Job: King's Cliffe SWM  
Title: Flow in culvert



Date Jan-06

Designed By JLM

File 10.01.06, 100 yr RP, 1...

Checked By

Micro Drainage

Simulation W.9.5

Graphs for Pipe 1.002 USMH Number 3  
Storm Duration 1440 mins (Summer) Return Period 100 years  
Status : OK

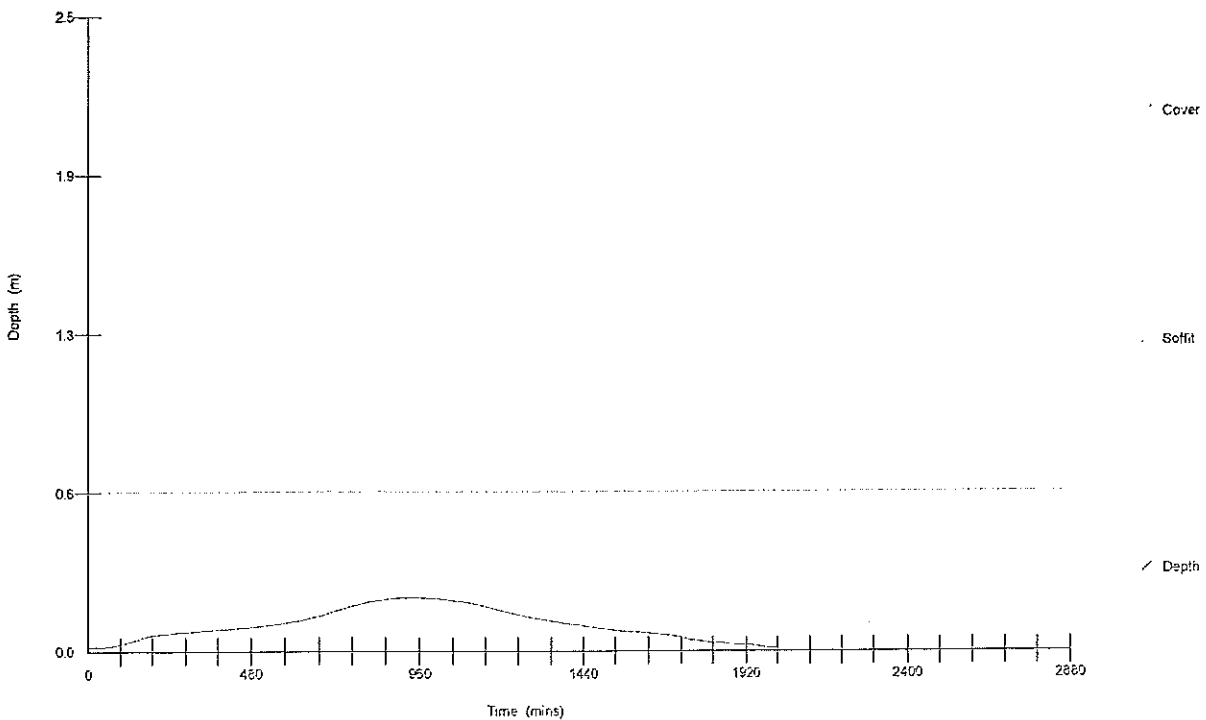
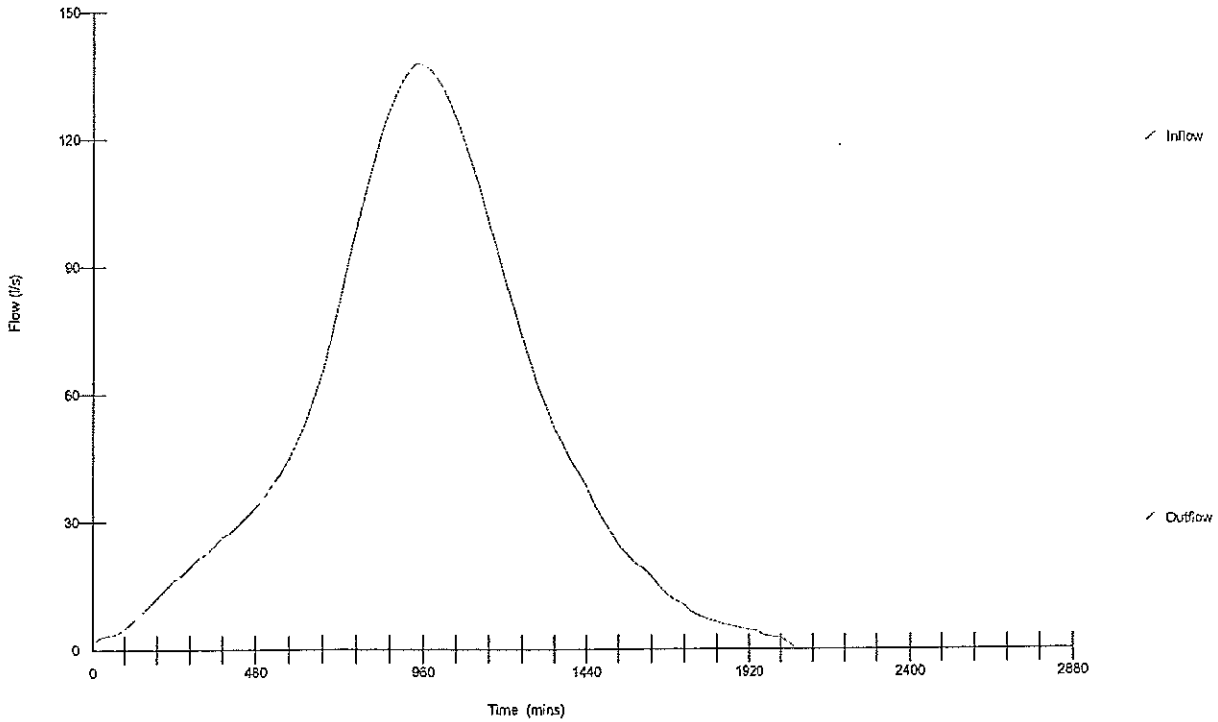

## **APPENDIX F**

### **BASELINE MONITORING RESULTS**

## Results for 08 February 2005

REF. NO		612164	612165	612166
LOCATION		SW Swall Inl S	SW Swall Inl N	SW Field RO
DATE		08/02/2005	08/02/2005	08/02/2005
Cadmium , Total as Cd	mg/l	<0.0005	<0.0005	<0.0005
Chromium , Total as Cr	mg/l	<0.005	<0.005	<0.005
Lead , Total as Pb	mg/l	<0.005	<0.005	0.020
Mercury , Total as Hg	mg/l	<0.0001	<0.0001	<0.0001
Nickel , Total as Ni	mg/l	<0.005	<0.005	<0.005
Zinc, Total as Zn	mg/l	<0.005	<0.005	0.087
pH		8.0	7.9	7.8
Conductivity- Electrical 20C	uS/cm	655	524	688
Ammoniacal Nitrogen as N	mg/l	1.6	<0.3	<0.3
Chloride as Cl	mg/l	11	7	63
Sulphate as SO4	mg/l	72	20	128
BOD + ATU (5 day)	mg/l	<1	<1	<1
Mecoprop	ug/l	<0.05	<0.05	<0.05
Trichloroethene	ug/l	<1	<1	<1
2 - Chlorophenol	ug/l	<20	<20	<20
2 - Methylphenol	ug/l	<20	<20	<20
2,4 - Dichlorophenol	ug/l	<20	<20	<20
2,4 - Dimethylphenol	ug/l	<20	<20	<20
2,4,6 - Trichlorophenol	ug/l	<20	<20	<20
3,5 Dimethylphenol	ug/l	<20	<20	<20
4-Chlorophenol	ug/l	<20	<20	<20
4-Methylphenol	ug/l	<20	<20	<20
Phenol	ug/l	<20	<20	<20
Toluene	ug/l	<0.4	<0.4	<0.4
Tributyltin	ug/l	<0.02	<0.02	<0.02
Arsenic (FILT) ICPMS	mg/l	<0.001	<0.001	<0.001
Selenium (T) ICPMS	mg/l	0.002	0.001	0.002
Comment				

## Results for 02 March 2005

REF. NO		631002	631003	631004	631005
LOCATION		SWSWALLI NLS	SWSWALLI NLN	SW Field RO	SW Road RO
DATE		02/03/2005	02/03/2005	02/03/2005	02/03/2005
Cadmium , Total as Cd	mg/l	<0.0005	<0.0005	<0.0005	
Chromium , Total as Cr	mg/l	<0.005	<0.005	<0.005	
Lead , Total as Pb	mg/l	<0.005	<0.005	0.010	
Mercury , Total as Hg	mg/l	<0.0001	<0.0001	<0.0001	
Nickel , Total as Ni	mg/l	<0.005	<0.005	<0.005	
Zinc, Total as Zn	mg/l	<0.005	<0.005	0.070	
pH		8.2	8.2	8.1	
Conductivity- Electrical 20C	uS/cm	529	555	2770	
Ammoniacal Nitrogen as N	mg/l	2.4	1.5	1.1	
Chloride as Cl	mg/l	12	9	807	
Sulphate as SO4	mg/l	48	21	141	
BOD + ATU (5 day)	mg/l	<1	<1	<1	
Mecoprop	ug/l	<0.04	<0.04	<0.04	
Trichloroethene	ug/l	<1	<1	<1	
2 - Chlorophenol	ug/l	<20	<20	<20	
2 - Methylphenol	ug/l	<20	<20	<20	
2,4 - Dichlorophenol	ug/l	<20	<20	<20	
2,4 - Dimethylphenol	ug/l	<20	<20	<20	
2,4,6 - Trichlorophenol	ug/l	<20	<20	<20	
3,5 Dimethylphenol	ug/l	<20	<20	<20	
4-Chlorophenol	ug/l	<20	<20	<20	
4-Methylphenol	ug/l	<20	<20	<20	
Phenol	ug/l	<20	<20	<20	
Toluene	ug/l	<0.4	<0.4	<0.4	
Tributyltin	ug/l	<0.02	<0.02	<0.02	
Arsenic (FILT) ICPMS	mg/l	<0.001	<0.001	0.003	
Selenium (T) ICPMS	mg/l	0.002	0.002	0.001	
Sample Received					Empty
Comment					

## Results for 24 March 2005

REF. NO		651596	651597	651598	651599
LOCATION		SW Swall N	SW Swall S	SW Field RO	SW Road RO
DATE		24/03/2005	24/03/2005	24/03/2005	24/03/2005
Cadmium, Total as Cd	mg/l	<0.0005	<0.0005	0.0010	
Chromium, Total as Cr	mg/l	<0.005	<0.005	<0.005	
Lead, Total as Pb	mg/l	0.009	0.011	0.016	
Mercury, Total as Hg	mg/l	<0.0001	<0.0001	<0.0001	
Nickel, Total as Ni	mg/l	<0.005	<0.005	<0.005	
Zinc, Total as Zn	mg/l	0.012	0.016	0.061	
pH		8.1	8.1	8.2	
Conductivity- Electrical 20C	uS/cm	515	669	805	
Ammoniacal Nitrogen as N	mg/l	0.4	0.4	0.5	
Chloride as Cl	mg/l	9	17	107	
Sulphate as SO4	mg/l	19	86	130	
D.O. concentration	mg/l	Sch`d	Sch`d	Sch`d	
BOD + ATU (5 day)	mg/l	<1	<1	<1	
Mecoprop	ug/l	<0.04	<0.04	0.186	
Trichloroethene	ug/l	<1	<1	<1	
2 - Chlorophenol	ug/l	<20	<20	<20	
2 - Methylphenol	ug/l	<20	<20	<20	
2,4 - Dichlorophenol	ug/l	<20	<20	<20	
2,4 - Dimethylphenol	ug/l	<20	<20	<20	
2,4,6 - Trichlorophenol	ug/l	<20	<20	<20	
3,5 Dimethylphenol	ug/l	<20	<20	<20	
4-Chlorophenol	ug/l	<20	<20	<20	
4-Methylphenol	ug/l	<20	<20	<20	
Phenol	ug/l	<20	<20	<20	
Toluene	ug/l	<0.4	<0.4	<0.4	
Tributyltin	ug/l	<0.02	<0.02	<0.02	
Arsenic (FILT) ICPMS	mg/l	0.005	0.005	0.005	
Selenium (T) ICPMS	mg/l	0.001	0.001	<0.001	
Sample Received					Empty
Comment					



## Results from 11 July 2005

REF. NO		769818
LOCATION		SWFIELD
DATE		11/07/2005
Cadmium , Total as Cd	mg/l	0.0010
Chromium , Total as Cr	mg/l	<0.005
Lead , Total as Pb	mg/l	<0.005
Mercury , Total as Hg	mg/l	<0.0001
Nickel , Total as Ni	mg/l	<0.005
Zinc, Total as Zn	mg/l	0.013
pH		7.9
Conductivity- Electrical 20C	uS/cm	534
Ammoniacal Nitrogen as N	mg/l	<0.3
Chloride as Cl	mg/l	9
Sulphate as SO4	mg/l	39
BOD + ATU (5 day)	mg/l	<1
Mecoprop	ug/l	<0.04
2 - Chlorophenol	ug/l	<20
2 - Methylphenol	ug/l	<20
2,4 - Dichlorophenol	ug/l	<20
2,4 - Dimethylphenol	ug/l	<20
2,4,6 - Trichlorophenol	ug/l	<20
3,5 Dimethylphenol	ug/l	<20
4-Chlorophenol	ug/l	<20
4-Methylphenol	ug/l	<20
Phenol	ug/l	<20
Tributyltin	ug/l	<0.05
Arsenic (FILT) ICPMS	mg/l	<0.001
Selenium (T) ICPMS	mg/l	<0.001
Trichloroethene	ug/l	<0.10
Toluene	ug/l	<0.10
Comment		

## Results for 25 July 2005

REF. NO		769817
LOCATION		SWFIELD
DATE		25/07/2005
Cadmium , Total as Cd	mg/l	0.0010
Chromium , Total as Cr	mg/l	<0.005
Lead , Total as Pb	mg/l	<0.005
Mercury , Total as Hg	mg/l	<0.0001
Nickel , Total as Ni	mg/l	<0.005
Zinc, Total as Zn	mg/l	0.005
pH		7.9
Conductivity- Electrical 20C	uS/cm	536
Ammoniacal Nitrogen as N	mg/l	<0.3
Chloride as Cl	mg/l	10
Sulphate as SO4	mg/l	38
BOD + ATU (5 day)	mg/l	<1
Mecoprop	ug/l	<0.04
2 - Chlorophenol	ug/l	<20
2 - Methylphenol	ug/l	<20
2,4 - Dichlorophenol	ug/l	<20
2,4 - Dimethylphenol	ug/l	<20
2,4,6 - Trichlorophenol	ug/l	<20
3,5 Dimethylphenol	ug/l	<20
4-Chlorophenol	ug/l	<20
4-Methylphenol	ug/l	<20
Phenol	ug/l	<20
Tributyltin	ug/l	<0.05
Arsenic (FILT) ICPMS	mg/l	<0.001
Selenium (T) ICPMS	mg/l	0.001
Trichloroethene	ug/l	<0.10
Toluene	ug/l	<0.10
Comment		

## Results for 14 October 2005

REF. NO		135905
LOCATION		SWROADRO
DATE		14/10/2005
Cadmium , Total as Cd	mg/l	<0.0005
Chromium , Total as Cr	mg/l	<0.005
Lead , Total as Pb	mg/l	0.020
Mercury , Total as Hg	mg/l	0.0001
Nickel , Total as Ni	mg/l	<0.005
Zinc, Total as Zn	mg/l	0.068
pH		6.7
Conductivity- Electrical 20C	uS/cm	150
Ammoniacal Nitrogen as N	mg/l	0.5
Chloride as Cl	mg/l	16
Sulphate as SO4	mg/l	5
BOD + ATU (5 day)	mg/l	4
Mecoprop	ug/l	<0.04
2 - Chlorophenol	ug/l	<20
2 - Methylphenol	ug/l	<20
2,4 - Dichlorophenol	ug/l	<20
2,4 - Dimethylphenol	ug/l	<20
2,4,6 - Trichlorophenol	ug/l	<20
3,5 Dimethylphenol	ug/l	<20
4-Chlorophenol	ug/l	<20
4-Methylphenol	ug/l	<20
Phenol	ug/l	<20
Tributyltin	ug/l	<0.02
Arsenic (FILT) ICPMS	mg/l	<0.001
Selenium, total by ICP-MS	mg/l	<0.001
Trichloroethene	ug/l	<0.10
Toluene	ug/l	<0.10
Comment		

## Results for 19 October 2005

REF. NO		135922
LOCATION		SWROADRO
DATE		19/10/2005
Cadmium , Total as Cd	mg/l	<0.0005
Chromium , Total as Cr	mg/l	<0.005
Lead , Total as Pb	mg/l	0.012
Mercury , Total as Hg	mg/l	0.0001
Nickel , Total as Ni	mg/l	<0.005
Zinc, Total as Zn	mg/l	0.045
pH		7.0
Conductivity- Electrical 20C	uS/cm	130
Ammoniacal Nitrogen as N	mg/l	<0.3
Chloride as Cl	mg/l	13
Sulphate as SO4	mg/l	<5
BOD + ATU (5 day)	mg/l	2
Mecoprop	ug/l	<0.04
2 - Chlorophenol	ug/l	<20
2 - Methylphenol	ug/l	<20
2,4 - Dichlorophenol	ug/l	<20
2,4 - Dimethylphenol	ug/l	<20
2,4,6 - Trichlorophenol	ug/l	<20
3,5 Dimethylphenol	ug/l	<20
4-Chlorophenol	ug/l	<20
4-Methylphenol	ug/l	<20
Phenol	ug/l	<20
Tributyltin	ug/l	<0.02
Arsenic (FILT) ICPMS	mg/l	<0.001
Selenium, total by ICP-MS	mg/l	<0.001
Trichloroethene	ug/l	<0.10
Toluene	ug/l	<0.10
Comment		

**APPENDIX G**

DRAWING 1621.SWM.10

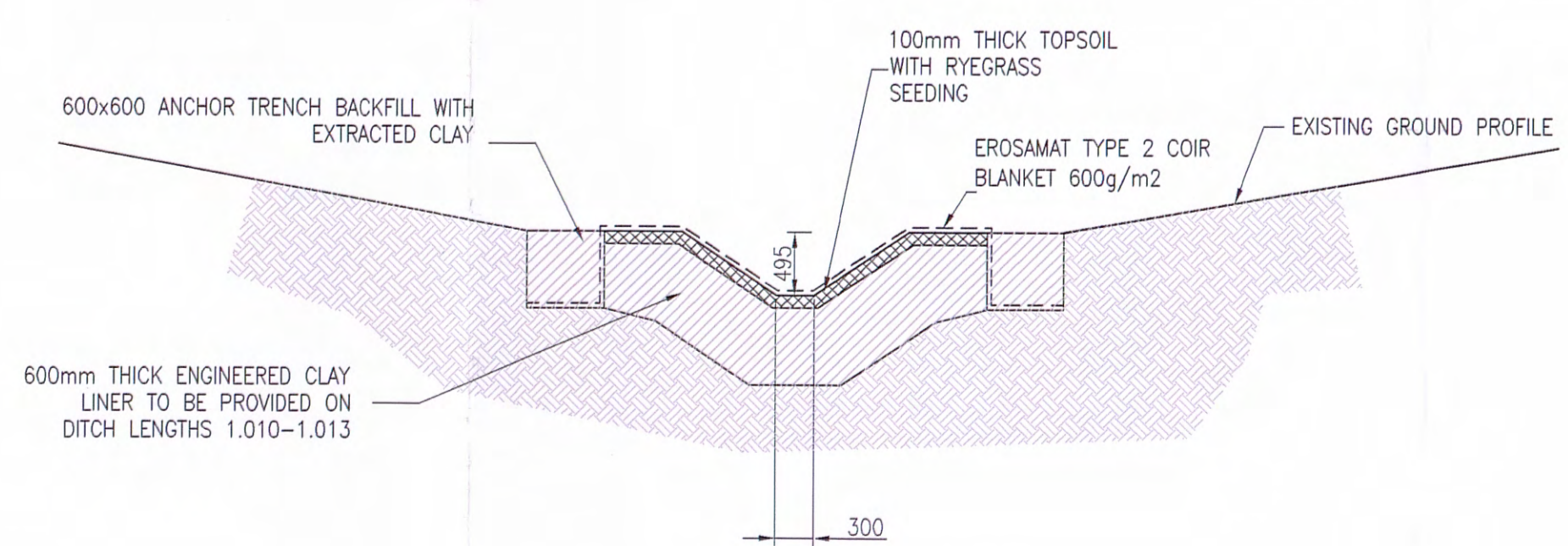

**TYPICAL DITCH DETAIL**  
 (BASE WIDTH AND SIDE SLOPE DEPTH MAY VARY)  
 1:50

- NOTES**
- THIS PLAN CONTAINS ORDNANCE SURVEY MAP DATA REPRODUCED WITH THE PERMISSION OF THE CONTROLLER OF HER MAJESTY'S STATIONARY OFFICE, CROWN COPYRIGHT (LICENCE No AL100036676)
  - REINSTATEMENT OF AGRICULTURAL LAND TO BE AGREED WITH THE LANDOWNER
- LEGEND**
- 2.005 PROPOSED SURFACE WATER DITCH ALIGNMENT AND REFERENCE
  - 2.020 PROPOSED POST SETTLEMENT CONTOURS
  - PROPOSED RISING MAIN
  - EXISTING WATER MAIN
  - + PYLON ON 11KV OVERHEAD POWER LINE

REV	RE-ROUTE OF RISING MAIN MODIFICATIONS	AS BY	JM CH	AP	DATE
E					10.1.06



**KINGS CLIFFE LANDFILL  
 SURFACE WATER  
 MANAGEMENT**

**OUTLINE SURFACE WATER  
 DRAINAGE PROPOSALS**

DRAWN BY	AK	DATE	17.08.2005
CHECKED BY	JLM	SCALE @ A1	1:2000
APPROVED BY	JM	ISSUING OFFICE	PEOVER
DRAWING NUMBER	1621.SWM.10	ISSUE	-
		REVISION	E

Egniol Limited  
 Printec House, Lower  
 Peover, Nr Knutsford,  
 WA16 9QQ  
 Tel: 01565 723618  
 Fax: 01565 723945  
 Website: www.egniol.co.uk



© COPYRIGHT EGNIO LIMITED - NOT TO BE COPIED OR REPRODUCED IN ANY WAY OR FORM WITHOUT PRIOR WRITTEN CONSENT FROM EGNIO LIMITED

**APPENDIX H**

**DRAWING 1621.SWM.11**

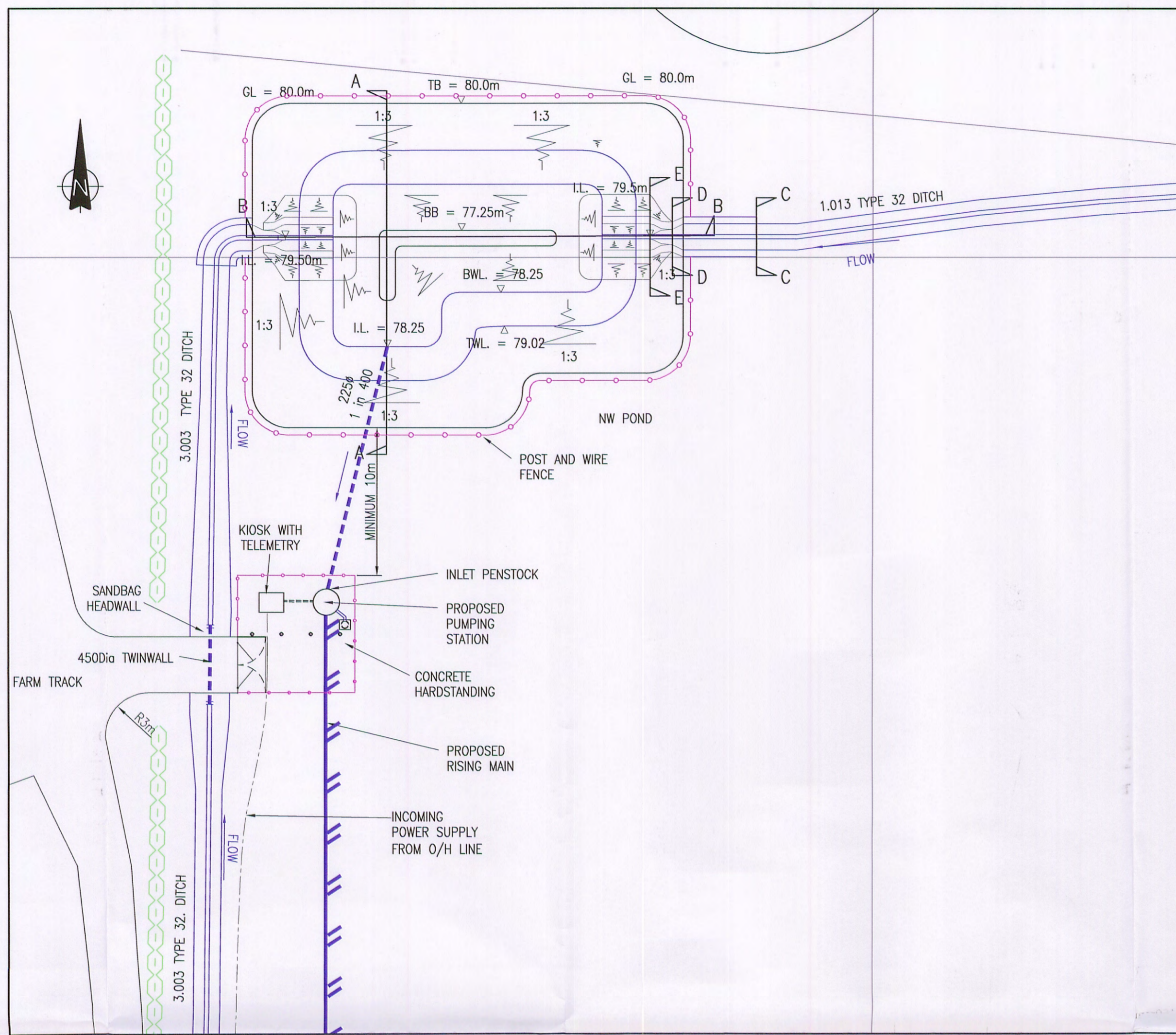

PROPOSED SURFACE WATER SETTLEMENT POND AND PUMPING STATION

SCALE 1:250

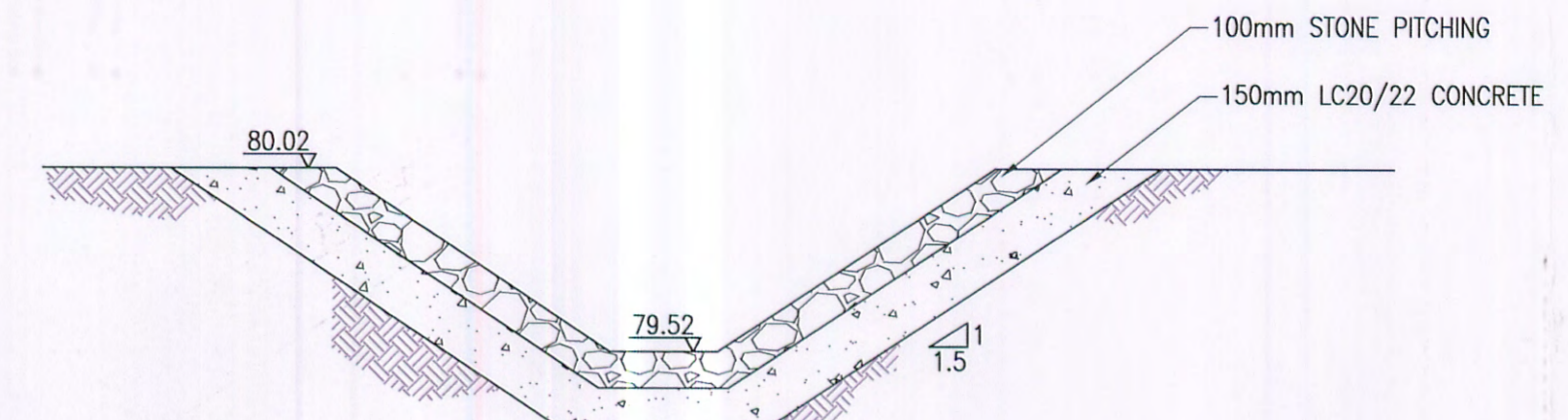

SECTION C-C

SCALE 1:20

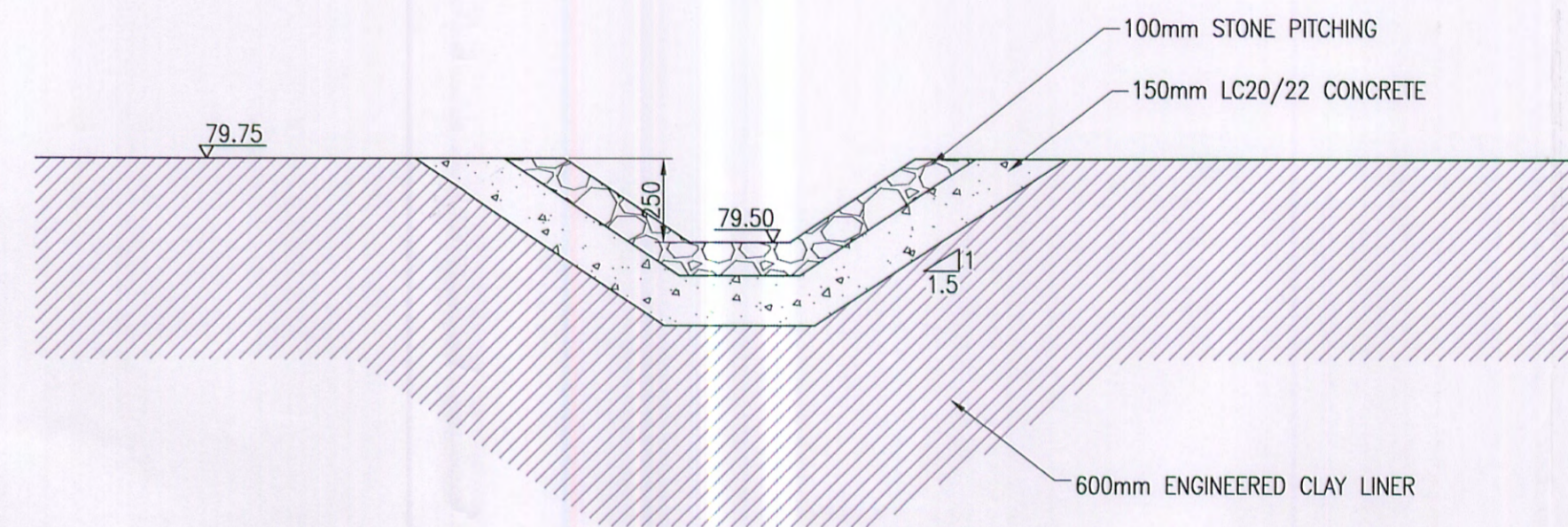

SECTION D-D

SCALE 1:20

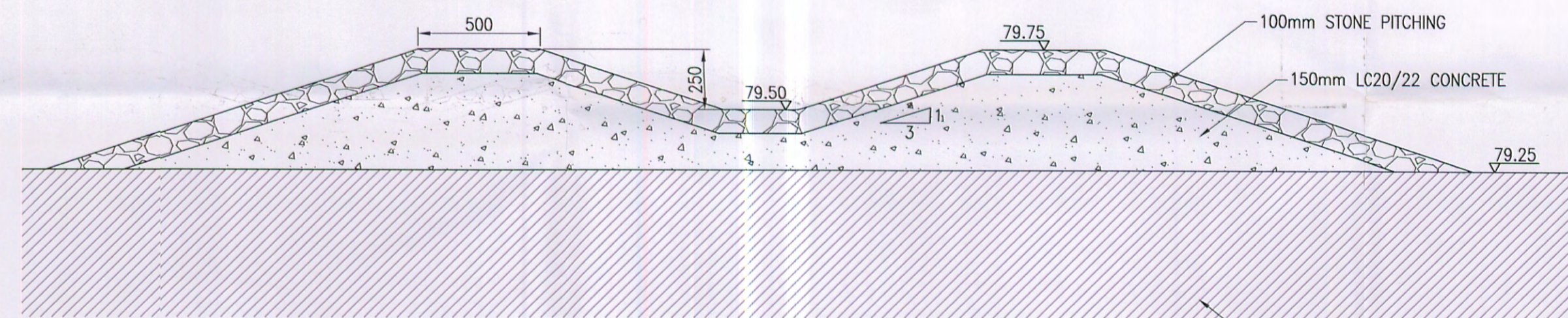

SECTION E-E

SCALE 1:20

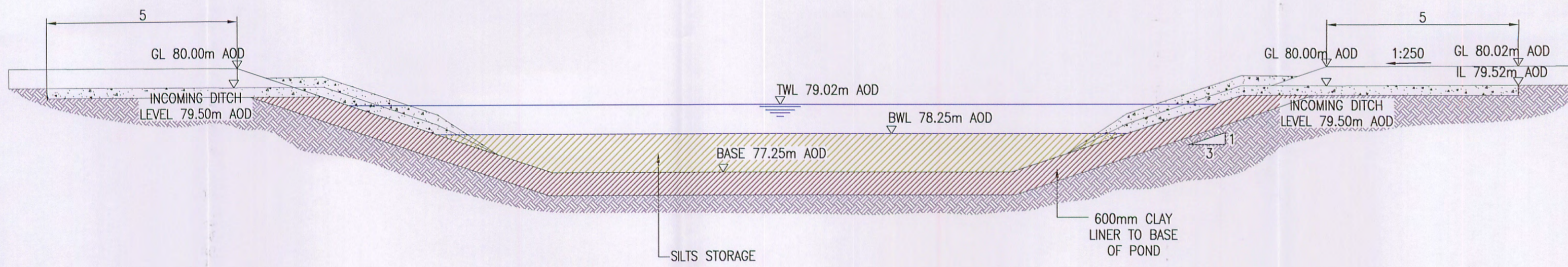

SECTION A-A THROUGH PROPOSED SETTLEMENT POND

SCALE 1:100

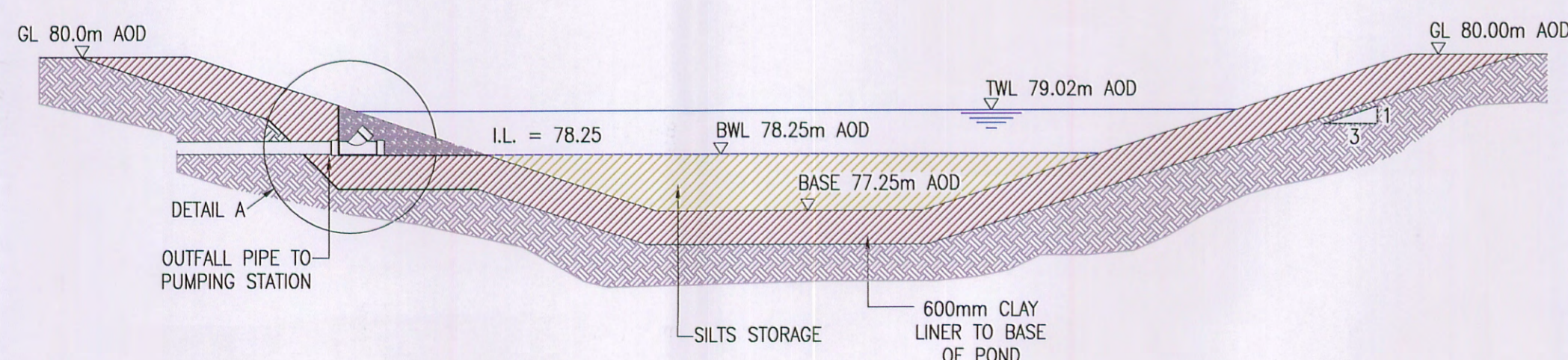

SECTION B-B THROUGH PROPOSED SETTLEMENT POND

SCALE 1:100

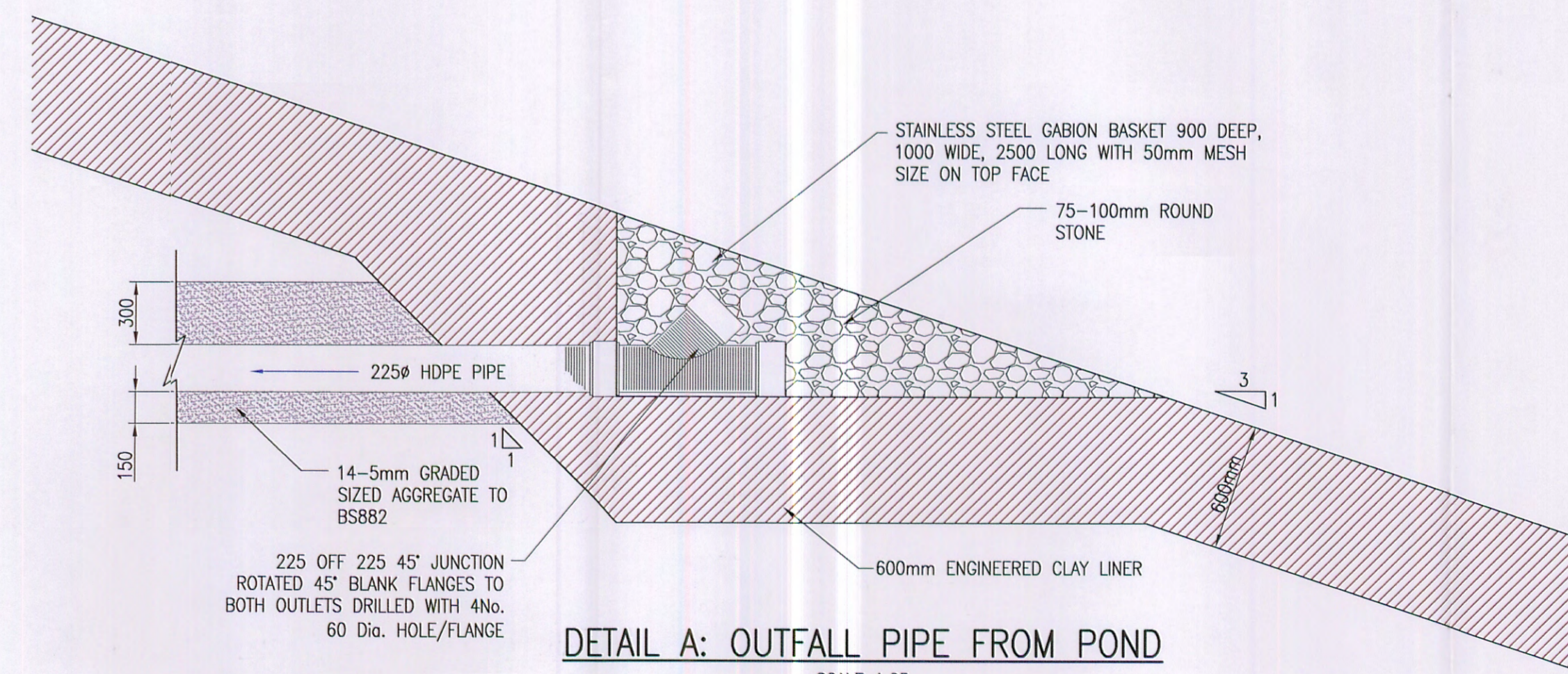

DETAIL A: OUTFALL PIPE FROM POND

SCALE 1:25

- NOTES
- SPECIFICATION TO BE "CIVIL ENGINEERING SPECIFICATION FOR THE WATER INDUSTRY, 5th EDITION" UNLESS DETAILED OTHERWISE.
  - FOR DETAILS OF PUMPING STATION SEE DRAWING 1621.SWM.12
  - SETTING OUT DETAILS FOR THE POND AND INLETS TO BE PROVIDED IN ELECTRONIC FORM

REV	MODIFICATIONS	BY	CH	AP	DATE
-----	---------------	----	----	----	------



KINGSLIFFE LANDFILL  
SITE SURFACE WATER  
MANAGEMENT

CONSTRUCTION DETAILS  
FOR NW POND

DRAWN BY	AK	DATE	15.11.2005
CHECKED BY	JLM	SCALE	AS SHOWN
APPROVED BY	JM	ISSUING OFFICE	PEOVER

DRAWING NUMBER	1621.SWM.11	ISSUE	Dr	REVISION	A
----------------	-------------	-------	----	----------	---

Egniol Limited  
Primtec House, Lower Peover,  
Nr Knutsford,  
WA16 9QQ  
Tel: 01565 723618  
Fax: 01565 723845  
Website: www.egniol.co.uk



© COPYRIGHT EGNOL LIMITED - NOT TO BE COPIED OR REPRODUCED IN ANY WAY OR FORM WITHOUT PRIOR WRITTEN CONSENT FROM EGNOL LIMITED



**APPENDIX I**

DRAWING 1621.SWM.14

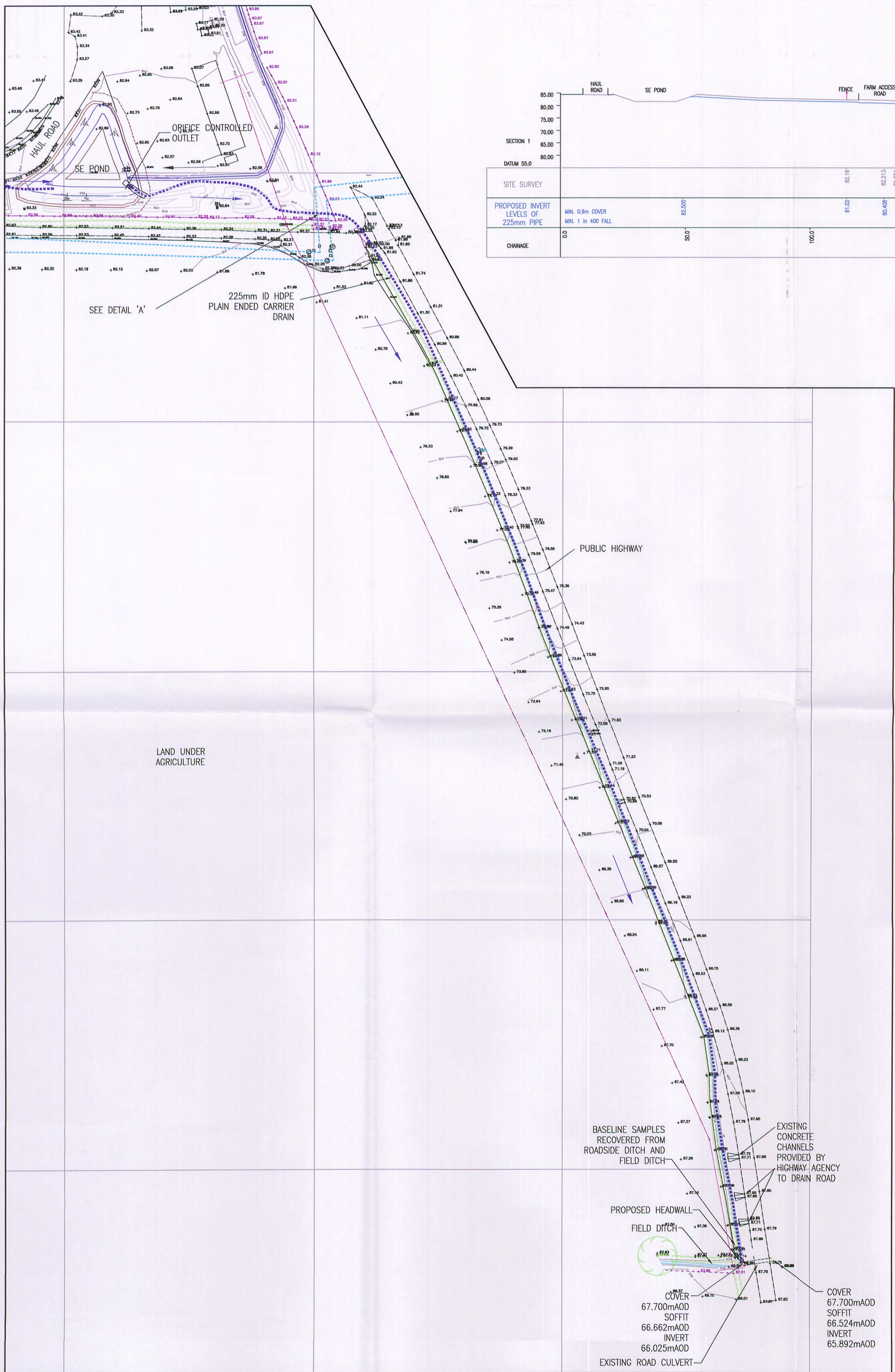

LAYOUT OF SOUTHERN PONDS AND OUTFALL

1:1000

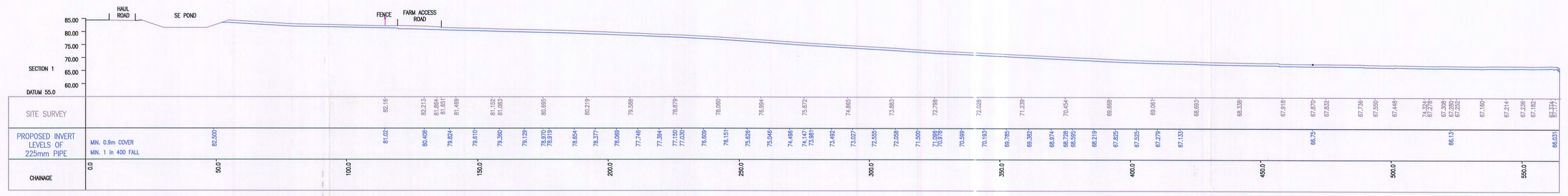

LONG SECTION THROUGH SOUTH EAST POND AND OUTFALL PIPE IN VERGE  
1:1000

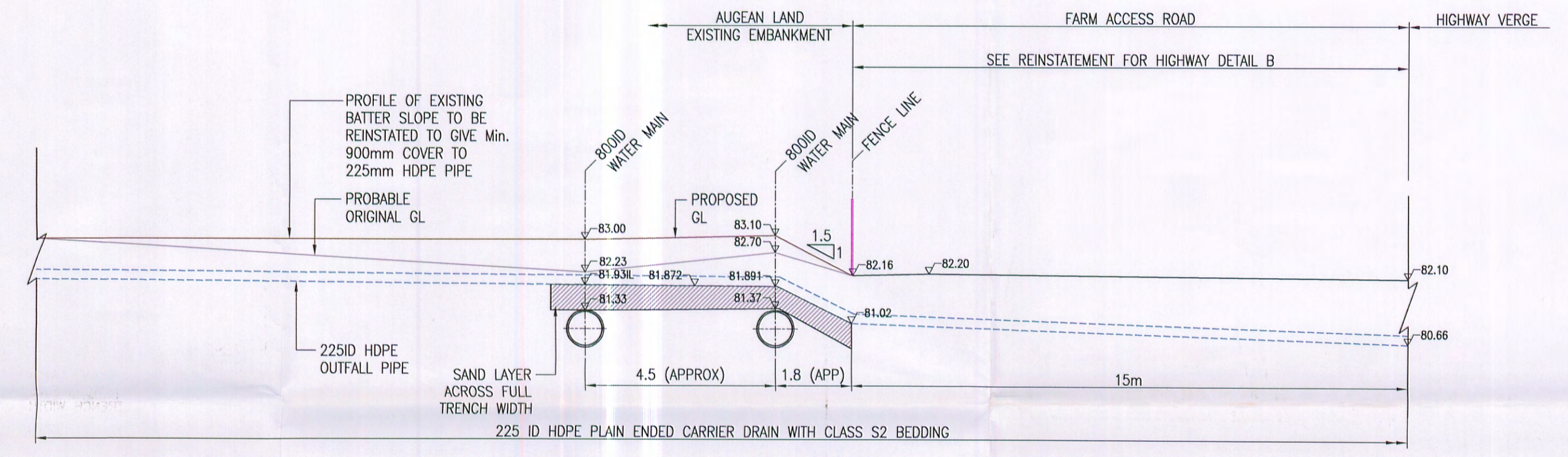

DETAIL A: WATERMAIN CROSSING DETAIL FROM SE POND  
1:50

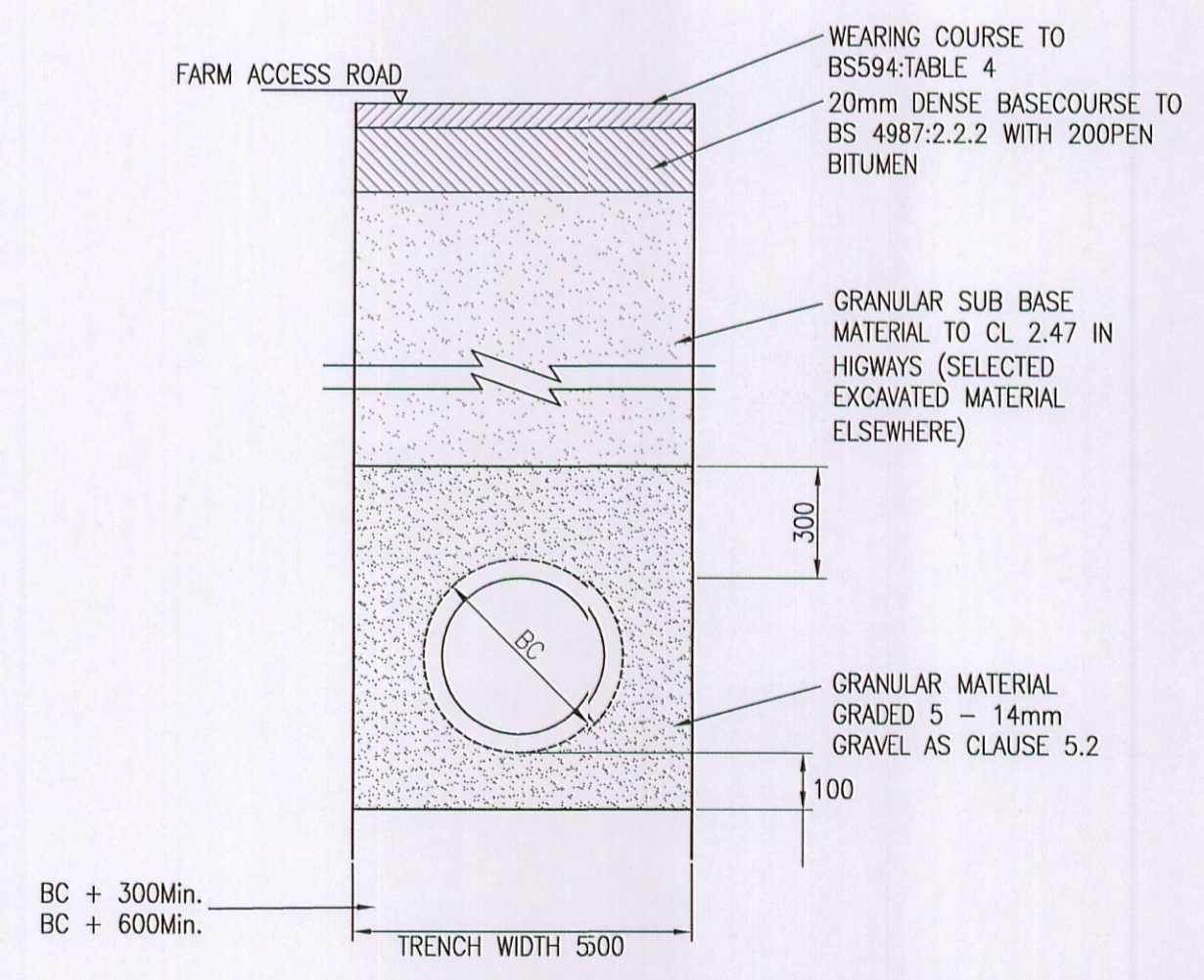

DETAIL B: CLASS "S2" DRAINAGE PIPE AND TRENCH AS BS EN 1295-1: 1998  
SCALE 1:20

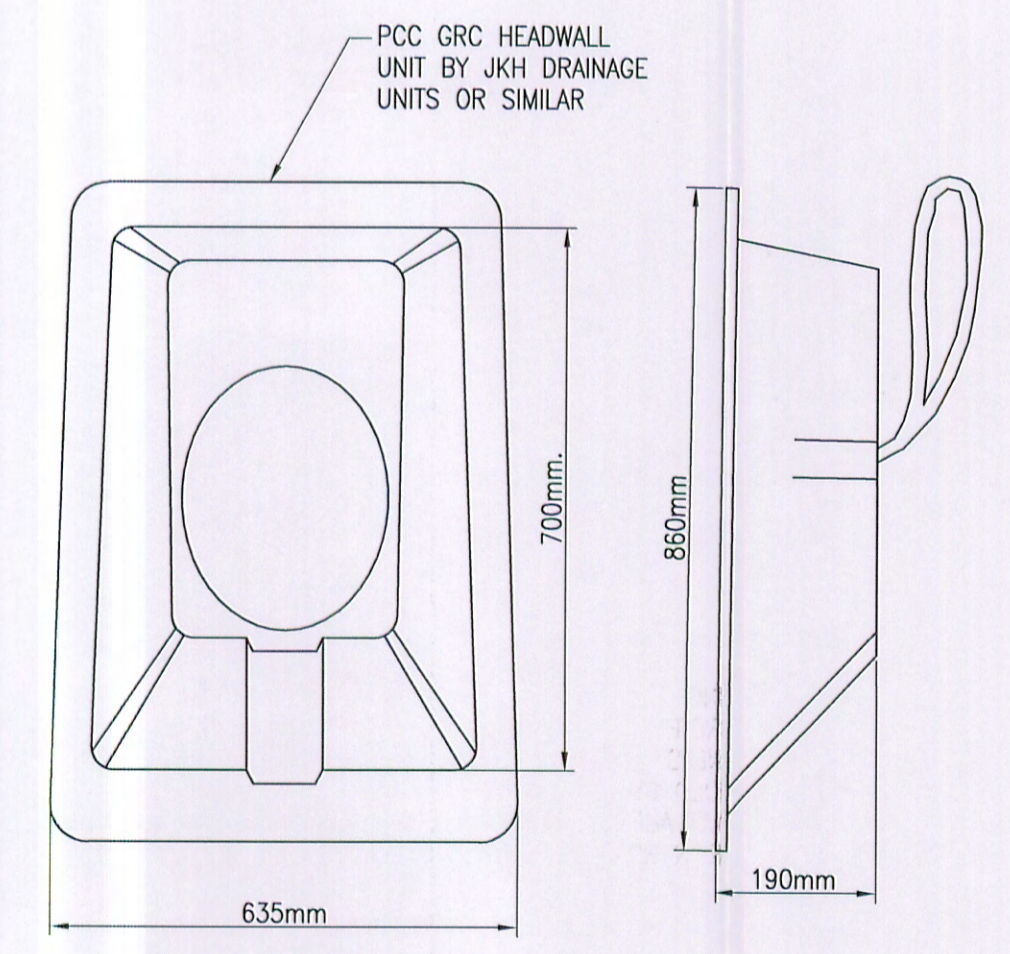

DETAIL C: OUTFALL DETAIL TO WATERCOURSE  
SCALE 1:10

- NOTES
- SPECIFICATION TO BE "CIVIL ENGINEERING SPECIFICATION FOR THE WATER INDUSTRY, 5th EDITION" UNLESS DETAILED OTHERWISE
  - HDPE PIPE TO COMPLY WITH ROAD AND BRIDGE AGREEMENT CERTIFICATE 00/R121

REV	MODIFICATIONS	BY	CH	AP	DATE

**Augean SOUTH LTD**

**KINGSLIFFE LANDFILL SITE SURFACE WATER MANAGEMENT**

**OUTFALL DETAILS FOR SE POND**

DRAWN BY	AK	DATE	17.08.2005
CHECKED BY	JLM	SCALE	A1 AS SHOWN
APPROVED BY	JM	ISSUING OFFICE	PEOVER

DRAWING NUMBER	1621.SWM.14	ISSUE	Dr	REVISION	-
----------------	-------------	-------	----	----------	---

Egniol Limited  
 Primtec House, Lower Peover,  
 Nr Knutsford,  
 WA16 9QQ  
 Tel: 01565 723618  
 Fax: 01565 723945  
 Website: www.egniol.co.uk

© COPYRIGHT EGNIO LIMITED - NOT TO BE COPIED OR REPRODUCED IN ANY WAY OR FORM WITHOUT PRIOR WRITTEN CONSENT FROM EGNIO LIMITED

**APPENDIX J**

**DRAWING 1621.SWM. 24**

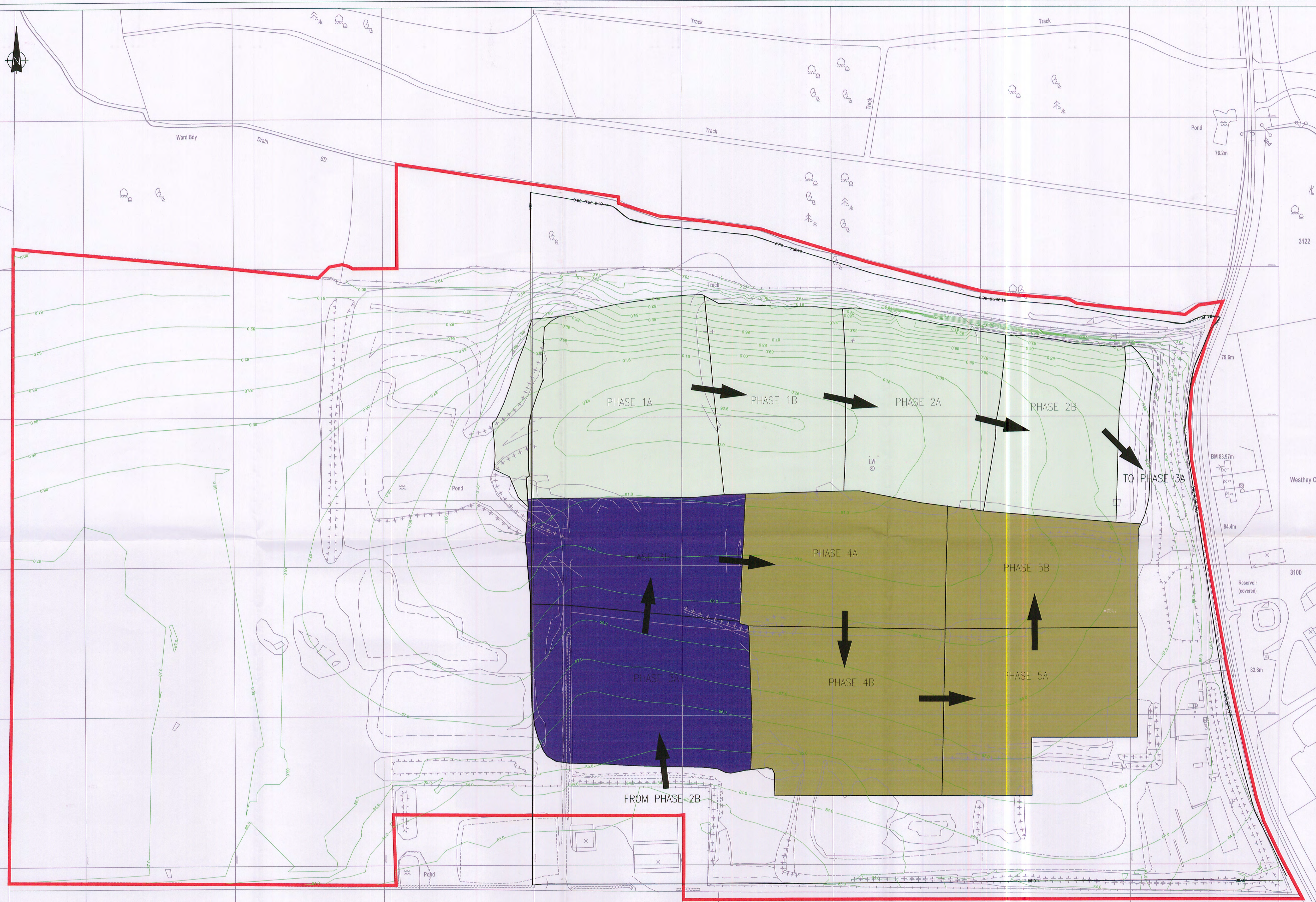

- NOTES
- FILLED AREAS
  - OPERATIONAL AREAS
  - FUTURE LANDFILLING OPERATIONS
  - DIRECTION OF LANDFILLING

REV	MODIFICATIONS	BY	CH	AP	DATE
-----	---------------	----	----	----	------



**KINGS CLIFFE LANDFILL SITE**

**PROGRESSIVE WASTE FILL**

DRAWN BY	AK	DATE	10.01.2006
----------	----	------	------------

CHECKED BY	MN	SCALE @ A1	1:1250
------------	----	------------	--------

APPROVED BY	MN	ISSUING OFFICE	ALFRETON
-------------	----	----------------	----------

DRAWING NUMBER	1621.SWM.24	ISSUE	Dr	REVISION	A
----------------	-------------	-------	----	----------	---

Egniol Limited  
 Amber Mill, Oakerthorpe,  
 Alfreton, Derbyshire,  
 DE55 7LL  
 Tel: 01773 520200  
 Fax: 01773 835439  
 Website: www.egniol.co.uk

1. THIS PLAN CONTAINS ORDNANCE SURVEY MAP DATA REPRODUCED WITH THE PERMISSION OF THE CONTROLLER OF HER MAJESTY'S STATIONERY OFFICE, CROWN COPYRIGHT © (LICENSE No AL100036676)

© COPYRIGHT EGNIO LIMITED - NOT TO BE COPIED OR REPRODUCED IN ANY WAY OR FORM WITHOUT PRIOR WRITTEN CONSENT FROM EGNIO LIMITED

**Egniol Consulting Limited**

*Head Office:*

Tre Felin  
Bangor  
Gwynedd  
LL57 4LH  
Telephone: 01248 355996  
Fax: 01248 371996

*Cheshire Office:*

Primtec House  
Hulme Lane  
Lower Peover  
Cheshire  
WA16 9QQ  
Telephone: 01565 723618  
Fax: 01565 723945

*Derbyshire Office:*

Amber Mill  
Oakerthorpe  
Alfreton  
Derbyshire  
DE55 7LL  
Telephone: 01773 520200  
Fax: 01773 835439

[www.egniol.com](http://www.egniol.com)

**e**gniol

**APPENDIX B**  
**TOPOGRAPHICAL SURVEY OF THE PROPOSED WESTERN EXTENSION**

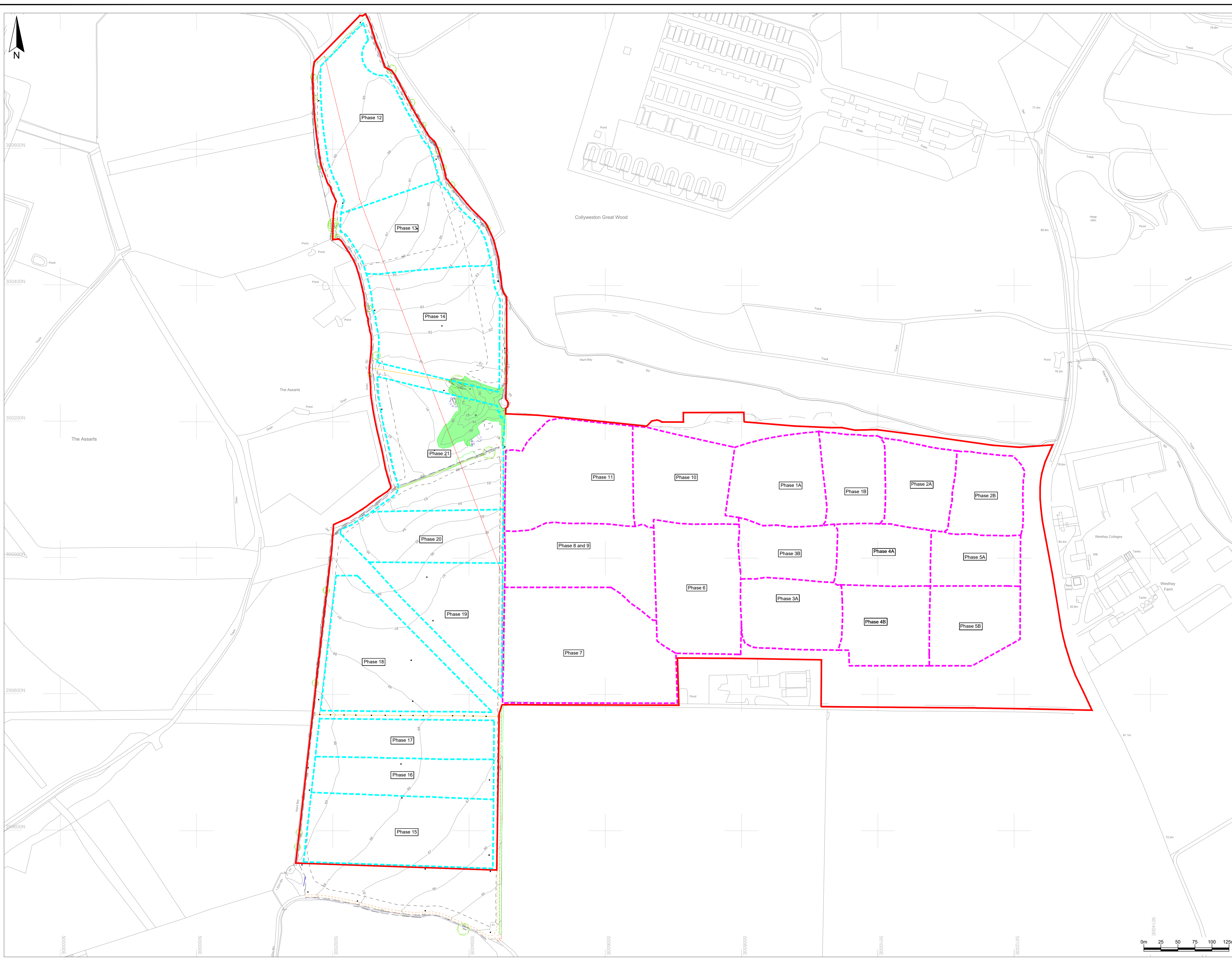

**Key / Notes**

- Approximate boundary of the area the subject of the application for the Development Consent Order
- Approximate phase boundary in the existing ENRMF
- Approximate phase boundary in the proposed western extension
- Bottom of Bank
- Bottom of Ditch
- Change of Surface
- Hedge
- Pipe
- Top of Bank
- Top of Ditch
- Track
- Overhead electricity cable (to be diverted)
- Contours (mAOD)
- Vegetation area
- o Tree

Notes:  
 Drawing based on LSS model reference 'AU-LSS-15846 LSS' and 'FULL SITE SURVEY UPDATE 24.05.2005 lss' provided by Egriol in 2005

The survey data is based on the ENRMF site control 'KINGSCONTROL' created using the co-ordinates of 6 survey points supplied by Augean PLC. The co-ordinate system was established and transformed via a OneStep transformation using a Leica GPS system in February 2007.

Rev	Final	KR	HL	LH	26/07/21
Site	Status	Dm	App	Chk	Date

Client  

 EAST NORTANTS RESOURCE MANAGEMENT FACILITY

Title  
 The current topography at the proposed western extension based on the topographical survey undertaken in January 2021 and the proposed phase boundaries

PINS document reference 5.3.18.1  
 Figure ES18.1 Scale 1:2,500@A1

Drawing Ref: AUKCW/07-21/22685  
 Reproduces scale mapping by permission of Ordnance Survey on behalf of The Controller of Her Majesty's Stationery Office. © Crown copyright 2017. All rights reserved. Licence number 100017818.

Beskley Colliery Offices, Main Road, Baxby, Atherstone, Warwickshire, CV9 2LE. Telephone: 01827 717891 Fax: 01827 718007

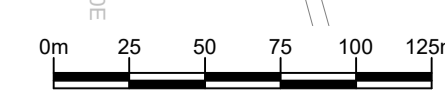

**APPENDIX C**  
**PROPOSED RESTORATION CONCEPT SCHEME**





- KEY**
- APPLICATION BOUNDARY
  - PROPOSED RESTORATION CONTOURS (At 1m AOD intervals)
  - EXISTING FOOTPATH
  - PROPOSED FOOTPATH
  - POSSIBLE NEW PATH ROUTE TO LINK WITH EXISTING PUBLIC RIGHT OF WAY, SUBJECT TO DISCUSSION & AGREEMENT
  - PROPOSED 4m WIDE TRACK FOR SITE AFTER CARE MAINTENANCE
  - PROPOSED LOCALLY NATIVE BROADLEAVED WOODLAND
  - PROPOSED SCRUB/NATURAL REGENERATION BROADLEAVED WOODLAND WITHIN GRASSLAND AREAS
  - PROPOSED INDIVIDUAL TREE OR SMALL TREE GROUP
  - EXISTING HEDGEROW (TO BE REINFORCED WITH TREES/SCRUBS WHERE CONSIDERED NECESSARY/DESIRABLE)
  - PROPOSED NATIVE HEDGEROW
  - PROPOSED NATIVE HEDGEROW WITH OCCASIONAL TREES
  - FORMER AGRICULTURAL LAND DEVELOPED AS MANAGED GRASSLAND AREA
  - EXISTING SPECIES-RICH NEUTRAL/CALCAREOUS GRASSLAND TO BE RETAINED
  - PROPOSED NEUTRAL/CALCAREOUS GRASSLAND (Depending on soil type)
  - EXISTING POND OUTSIDE THE APPLICATION BOUNDARY
  - PROPOSED POND FOR THE PURPOSE OF ENHANCING BIODIVERSITY AND ATTRACTING NEWTS. EXACT LOCATIONS TO BE DETERMINED DURING RESTORATION WORKS
  - HIBERNACULA TO BE CONSTRUCTED IN CLOSE PROXIMITY TO PROPOSED PONDS
  - PROPOSED ATTENUATION FEATURE
  - APPROX. 0.5m HIGH BLIND AROUND ATTENUATION BASIN C1 TO CONTAIN 1 IN 100 YEAR EVENT. BLIND TO BE PLANTED WITH SCRUBBY SPECIES
  - PUBLIC CAR PARK AREA ACCESSED FROM EXISTING MAIN SITE ENTRANCE
  - INDICATIVE CROSS SECTIONS (Refer to Drawing No. ENORTH4028)

**Proposed Tree and Shrub Planting Palette**  
 The proposed planting blocks across the restored site landscape would be planted with a selection of the following tree and shrub species which are characteristic of the surrounding landscape:

**Trees:**  
 Ash - *Fraxinus excelsior*  
 Field Maple - *Acer campestre*  
 Pedunculate Oak - *Quercus robur*  
 Silver Birch - *Betula pendula*  
 Small leaved lime - *Tilia cordata*  
 Wild Service Tree - *Sorbus torminalis*  
 Wych elm - *Ulmus glabra*

**Shrubs/Scrub/Climbers:**  
 Black bryony - *Tamus communis*  
 Blackthorn - *Prunus spinosa*  
 Bramble - *Rubus fruticosus*  
 Buckthorn - *Rhamnus cathartica*  
 Dewberry - *Rubus caesius*  
 Dog rose - *Rosa canina*  
 Dogwood - *Cornus sanguinea*  
 Elder - *Sambucus nigra*  
 Goat willow - *Salix caprea*  
 Gorse - *Ulex europaeus*  
 Grey willow - *Salix cinerea*  
 Hawthorn - *Crataegus monogyna*  
 Hazel - *Cornus avellana*  
 Ivy - *Hedera helix*  
 Spindle - *Euonymus europaea*  
 Spurge laurel - *Daphne laureola*  
 Traveller's joy - *Clematis vitalba*  
 Wayfaring tree - *Viburnum lantana*  
 White bryony - *Bryonia dioica*  
 Wild privet - *Ligustrum vulgare*

0 10 20 30 40 50 60 70 80 90 100 METRES  
 SCALE 1:2500

Client: **Augean SOUTH LTD**

Site: EAST NORTHANTS RESOURCE MANAGEMENT FACILITY

Project: PROPOSED WESTERN EXTENSION

Drawing Title: RESTORATION CONCEPT SCHEME

Date: JULY 2021 | Drawing No: ENORTH028

Scale: 1:2,500 @ A1

File Ref: 2107\_008\_008\_ENORTH028\_Restoration Plan | Revision: 0

DB Landscape Consultancy | T: 01344 624 760 | M: 07786 081 361 | dave@db-landscape.co.uk | www.db-landscape.co.uk

**APPENDIX D**  
**GREENFIELD RUNOFF CALCULATIONS**

Table D1

Calculation of the greenfield surface water runoff rate for the catchment draining to the east based on the method presented in The Institute of Hydrology, 1994. Flood estimation for small catchments. Report number 124.

Parameter (units)	Units		Source/Justification
Area of catchment	km <sup>2</sup>	0.05	Table 1 and as shown on Figure 3.
Area of catchment in SOIL class 1	km <sup>2</sup>	0.05	Soil type at and in the vicinity of the site prior to extraction based on the soil maps presented in the Flood Studies Report published by the The Institute of Hydrology dated 1993.
Area of catchment in SOIL class 2	km <sup>2</sup>	0.00	
Area of catchment in SOIL class 3	km <sup>2</sup>	0.00	
Area of catchment in SOIL class 4	km <sup>2</sup>	0.00	
Area of catchment in SOIL class 5	km <sup>2</sup>	0.00	
Soil index (SOIL)	n/a	0.1	Calculated from the weighted sum of the fractions of the surface areas within the catchment which have different soil types
Standard average annual rainfall (SAAR)	mm	575	FEH catchment descriptor
Greenfield surface water run-off rate for 50ha site (Q <sub>50ha</sub> )	m <sup>3</sup> /s	0.007	
Correction	m <sup>3</sup> /s	0.0993	
Greenfield surface water run-off rate (Q <sub>bar<sub>rural</sub></sub> )	m <sup>3</sup> /s	0.001	Calculated.
Greenfield surface water run-off rate (Q <sub>bar<sub>rural</sub></sub> )	m <sup>3</sup> /day	57	Calculated.
1 in 1 year surface water runoff for rainfall	m <sup>3</sup> /s	0.001	Calculated assuming a 1 year growth curve factor of 0.87. The 1 in 1 year growth curve factor was determined using information obtained using the greenfield runoff estimation tool presented on the UK Sustainable Drainage website ( <a href="http://www.uksuds.com/greenfieldrunoff_js.htm">http://www.uksuds.com/greenfieldrunoff_js.htm</a> ).
1 in 1 year surface water runoff for rainfall	m <sup>3</sup> /day	50	Calculated.
1 in 30 year surface water runoff for rainfall	m <sup>3</sup> /s	0.002	Calculated assuming a 30 year growth curve factor of 2.55. The 1 in 30 year growth curve factor was determined using information obtained using the greenfield runoff estimation tool presented on the UK Sustainable Drainage website ( <a href="http://www.uksuds.com/greenfieldrunoff_js.htm">http://www.uksuds.com/greenfieldrunoff_js.htm</a> ).
1 in 30 year surface water runoff for rainfall	m <sup>3</sup> /day	146	Calculated.
1 in 100 year surface water runoff for rainfall	m <sup>3</sup> /s	0.002	Calculated assuming a 100 year growth curve factor of 3.56. The 1 in 100 year growth curve factor was determined using information obtained using the greenfield runoff estimation tool presented on the UK Sustainable Drainage website ( <a href="http://www.uksuds.com/greenfieldrunoff_js.htm">http://www.uksuds.com/greenfieldrunoff_js.htm</a> ).
1 in 100 year surface water runoff for rainfall	m <sup>3</sup> /day	204	Calculated.
1 in 100 year surface water runoff for rainfall plus 40%	m <sup>3</sup> /s	0.003	Calculated assuming a 100 year growth curve factor of 3.56 and a 40% allowance for increased rainfall intensity as a result of climate change. The 1 in 100 year growth curve factor was determined using information obtained using the greenfield runoff estimation tool presented on the UK Sustainable Drainage website ( <a href="http://www.uksuds.com/greenfieldrunoff_js.htm">http://www.uksuds.com/greenfieldrunoff_js.htm</a> ).
1 in 100 year surface water runoff for rainfall plus 40%	m <sup>3</sup> /day	285	Calculated.

Table D2

Calculation of the greenfield surface water runoff rate for the catchment draining to the swallow hole based on the method presented in The Institute of Hydrology, 1994. Flood estimation for small catchments. Report number 124.

Parameter (units)	Units		Source/Justification
Area of catchment	km <sup>2</sup>	0.16	Table 1 and as shown on Figure 3.
Area of catchment in SOIL class 1	km <sup>2</sup>	0.16	Soil type at and in the vicinity of the site prior to extraction based on the soil maps presented in the Flood Studies Report published by the The Institute of Hydrology dated 1993.
Area of catchment in SOIL class 2	km <sup>2</sup>	0.00	
Area of catchment in SOIL class 3	km <sup>2</sup>	0.00	
Area of catchment in SOIL class 4	km <sup>2</sup>	0.00	
Area of catchment in SOIL class 5	km <sup>2</sup>	0.00	
Soil index (SOIL)	n/a	0.1	Calculated from the weighted sum of the fractions of the surface areas within the catchment which have different soil types
Standard average annual rainfall (SAAR)	mm	575	FEH catchment descriptor
Greenfield surface water run-off rate for 50ha site (Q <sub>50ha</sub> )	m <sup>3</sup> /s	0.007	
Correction	m <sup>3</sup> /s	0.3102	
Greenfield surface water run-off rate (Q <sub>bar<sub>rural</sub></sub> )	m <sup>3</sup> /s	0.002	Calculated.
Greenfield surface water run-off rate (Q <sub>bar<sub>rural</sub></sub> )	m <sup>3</sup> /day	179	Calculated.
1 in 1 year surface water runoff for rainfall	m <sup>3</sup> /s	0.002	Calculated assuming a 1 year growth curve factor of 0.87. The 1 in 1 year growth curve factor was determined using information obtained using the greenfield runoff estimation tool presented on the UK Sustainable Drainage website ( <a href="http://www.uksuds.com/greenfieldrunoff_js.htm">http://www.uksuds.com/greenfieldrunoff_js.htm</a> ).
1 in 1 year surface water runoff for rainfall	m <sup>3</sup> /day	156	Calculated.
1 in 30 year surface water runoff for rainfall	m <sup>3</sup> /s	0.005	Calculated assuming a 30 year growth curve factor of 2.55. The 1 in 30 year growth curve factor was determined using information obtained using the greenfield runoff estimation tool presented on the UK Sustainable Drainage website ( <a href="http://www.uksuds.com/greenfieldrunoff_js.htm">http://www.uksuds.com/greenfieldrunoff_js.htm</a> ).
1 in 30 year surface water runoff for rainfall	m <sup>3</sup> /day	456	Calculated.
1 in 100 year surface water runoff for rainfall	m <sup>3</sup> /s	0.007	Calculated assuming a 100 year growth curve factor of 3.56. The 1 in 100 year growth curve factor was determined using information obtained using the greenfield runoff estimation tool presented on the UK Sustainable Drainage website ( <a href="http://www.uksuds.com/greenfieldrunoff_js.htm">http://www.uksuds.com/greenfieldrunoff_js.htm</a> ).
1 in 100 year surface water runoff for rainfall	m <sup>3</sup> /day	637	Calculated.
1 in 100 year surface water runoff for rainfall plus 40%	m <sup>3</sup> /s	0.010	Calculated assuming a 100 year growth curve factor of 3.56 and a 40% allowance for increased rainfall intensity as a result of climate change. The 1 in 100 year growth curve factor was determined using information obtained using the greenfield runoff estimation tool presented on the UK Sustainable Drainage website ( <a href="http://www.uksuds.com/greenfieldrunoff_js.htm">http://www.uksuds.com/greenfieldrunoff_js.htm</a> ).
1 in 100 year surface water runoff for rainfall plus 40%	m <sup>3</sup> /day	891	Calculated.

Table D3

Calculation of the greenfield surface water runoff rate for the catchment draining to the south based on the method presented in The Institute of Hydrology, 1994. Flood estimation for small catchments. Report number 124.

Parameter (units)	Units		Source/Justification
Area of catchment	km <sup>2</sup>	0.06	Table 1 and as shown on Figure 3.
Area of catchment in SOIL class 1	km <sup>2</sup>	0.06	Soil type at and in the vicinity of the site prior to extraction based on the soil maps presented in the Flood Studies Report published by the The Institute of Hydrology dated 1993.
Area of catchment in SOIL class 2	km <sup>2</sup>	0.00	
Area of catchment in SOIL class 3	km <sup>2</sup>	0.00	
Area of catchment in SOIL class 4	km <sup>2</sup>	0.00	
Area of catchment in SOIL class 5	km <sup>2</sup>	0.00	
Soil index (SOIL)	n/a	0.1	Calculated from the weighted sum of the fractions of the surface areas within the catchment which have different soil types
Standard average annual rainfall (SAAR)	mm	575	FEH catchment descriptor
Greenfield surface water run-off rate for 50ha site (Q <sub>50ha</sub> )	m <sup>3</sup> /s	0.007	
Correction	m <sup>3</sup> /s	0.1282	
Greenfield surface water run-off rate (Q <sub>bar<sub>rural</sub></sub> )	m <sup>3</sup> /s	0.001	Calculated.
Greenfield surface water run-off rate (Q <sub>bar<sub>rural</sub></sub> )	m <sup>3</sup> /day	74	Calculated.
1 in 1 year surface water runoff for rainfall	m <sup>3</sup> /s	0.001	Calculated assuming a 1 year growth curve factor of 0.87. The 1 in 1 year growth curve factor was determined using information obtained using the greenfield runoff estimation tool presented on the UK Sustainable Drainage website ( <a href="http://www.uksuds.com/greenfieldrunoff_js.htm">http://www.uksuds.com/greenfieldrunoff_js.htm</a> ).
1 in 1 year surface water runoff for rainfall	m <sup>3</sup> /day	64	Calculated.
1 in 30 year surface water runoff for rainfall	m <sup>3</sup> /s	0.002	Calculated assuming a 30 year growth curve factor of 2.55. The 1 in 30 year growth curve factor was determined using information obtained using the greenfield runoff estimation tool presented on the UK Sustainable Drainage website ( <a href="http://www.uksuds.com/greenfieldrunoff_js.htm">http://www.uksuds.com/greenfieldrunoff_js.htm</a> ).
1 in 30 year surface water runoff for rainfall	m <sup>3</sup> /day	188	Calculated.
1 in 100 year surface water runoff for rainfall	m <sup>3</sup> /s	0.003	Calculated assuming a 100 year growth curve factor of 3.56. The 1 in 100 year growth curve factor was determined using information obtained using the greenfield runoff estimation tool presented on the UK Sustainable Drainage website ( <a href="http://www.uksuds.com/greenfieldrunoff_js.htm">http://www.uksuds.com/greenfieldrunoff_js.htm</a> ).
1 in 100 year surface water runoff for rainfall	m <sup>3</sup> /day	263	Calculated.
1 in 100 year surface water runoff for rainfall plus 40%	m <sup>3</sup> /s	0.004	Calculated assuming a 100 year growth curve factor of 3.56 and a 40% allowance for increased rainfall intensity as a result of climate change. The 1 in 100 year growth curve factor was determined using information obtained using the greenfield runoff estimation tool presented on the UK Sustainable Drainage website ( <a href="http://www.uksuds.com/greenfieldrunoff_js.htm">http://www.uksuds.com/greenfieldrunoff_js.htm</a> ).
1 in 100 year surface water runoff for rainfall plus 40%	m <sup>3</sup> /day	368	Calculated.

Table D4

## Comparison of Qbar calculations with 2l/s/ha

Catchment	Area (m <sup>2</sup> )	Qbar IOH124 (l/s)	Qbar UKSUDS FEH STAT (l/s)	2l/s/ha (l/s)
Catchment draining to the east	49,650	0.66	13.14	<b>9.93</b>
Catchment draining to the swallow hole	155,100	2.07	41.06	<b>31.02</b>
Catchment draining to the south	64,100	0.86	16.97	<b>12.82</b>

Calculated by:

Site name:

Site location:

### Site Details

Latitude:

Longitude:

Reference:

Date:

This is an estimation of the greenfield runoff rates that are used to meet normal best practice criteria in line with Environment Agency guidance "Rainfall runoff management for developments", SC030219 (2013), the SuDS Manual C753 (Ciria, 2015) and the non-statutory standards for SuDS (Defra, 2015). This information on greenfield runoff rates may be the basis for setting consents for the drainage of surface water runoff from sites.

### Runoff estimation approach

### Site characteristics

Total site area (ha):

### Methodology

$Q_{MED}$  estimation method:

BFI and SPR method:

HOST class:

BFI / BFIHOST:

$Q_{MED}$  (l/s):

$Q_{BAR}$  /  $Q_{MED}$  factor:

### Notes

#### (1) Is $Q_{BAR} < 2.0$ l/s/ha?

When  $Q_{BAR}$  is  $< 2.0$  l/s/ha then limiting discharge rates are set at 2.0 l/s/ha.

#### (2) Are flow rates $< 5.0$ l/s?

Where flow rates are less than 5.0 l/s consent for discharge is usually set at 5.0 l/s if blockage from vegetation and other materials is possible. Lower consent flow rates may be set where the blockage risk is addressed by using appropriate drainage elements.

#### (3) Is $SPR/SPRHOST \leq 0.3$ ?

Where groundwater levels are low enough the use of soakaways to avoid discharge offsite would normally be preferred for disposal of surface water runoff.

### Hydrological characteristics

	Default	Edited
SAAR (mm):	579	579
Hydrological region:	5	5
Growth curve factor 1 year:	0.87	0.87
Growth curve factor 30 years:	2.45	2.45
Growth curve factor 100 years:	3.56	3.56
Growth curve factor 200 years:	4.21	4.21

### Greenfield runoff rates

	Default	Edited
$Q_{BAR}$ (l/s):	13.14	13.14
1 in 1 year (l/s):	11.43	11.43
1 in 30 years (l/s):	32.2	32.2
1 in 100 year (l/s):	46.79	46.79
1 in 200 years (l/s):	55.33	55.33

This report was produced using the greenfield runoff tool developed by HR Wallingford and available at [www.uksuds.com](http://www.uksuds.com). The use of this tool is subject to the UK SuDS terms and conditions and licence agreement, which can both be found at [www.uksuds.com/terms-and-conditions.htm](http://www.uksuds.com/terms-and-conditions.htm). The outputs from this tool are estimates of greenfield runoff rates. The use of these results is the responsibility of the users of this tool. No liability will be accepted by HR Wallingford, the Environment Agency, CEH, Hydrosolutions or any other organisation for the use of this data in the design or operational characteristics of any drainage scheme.

Calculated by:

Site name:

Site location:

### Site Details

Latitude:

Longitude:

Reference:

Date:

This is an estimation of the greenfield runoff rates that are used to meet normal best practice criteria in line with Environment Agency guidance "Rainfall runoff management for developments", SC030219 (2013), the SuDS Manual C753 (Ciria, 2015) and the non-statutory standards for SuDS (Defra, 2015). This information on greenfield runoff rates may be the basis for setting consents for the drainage of surface water runoff from sites.

### Runoff estimation approach

### Site characteristics

Total site area (ha):

### Methodology

$Q_{MED}$  estimation method:

BFI and SPR method:

HOST class:

BFI / BFIHOST:

$Q_{MED}$  (l/s):

$Q_{BAR}$  /  $Q_{MED}$  factor:

### Notes

#### (1) Is $Q_{BAR} < 2.0$ l/s/ha?

When  $Q_{BAR}$  is  $< 2.0$  l/s/ha then limiting discharge rates are set at 2.0 l/s/ha.

#### (2) Are flow rates $< 5.0$ l/s?

Where flow rates are less than 5.0 l/s consent for discharge is usually set at 5.0 l/s if blockage from vegetation and other materials is possible. Lower consent flow rates may be set where the blockage risk is addressed by using appropriate drainage elements.

#### (3) Is $SPR/SPRHOST \leq 0.3$ ?

Where groundwater levels are low enough the use of soakaways to avoid discharge offsite would normally be preferred for disposal of surface water runoff.

### Hydrological characteristics

	Default	Edited
SAAR (mm):	579	579
Hydrological region:	5	5
Growth curve factor 1 year:	0.87	0.87
Growth curve factor 30 years:	2.45	2.45
Growth curve factor 100 years:	3.56	3.56
Growth curve factor 200 years:	4.21	4.21

### Greenfield runoff rates

	Default	Edited
$Q_{BAR}$ (l/s):	41.06	41.06
1 in 1 year (l/s):	35.72	35.72
1 in 30 years (l/s):	100.59	100.59
1 in 100 year (l/s):	146.16	146.16
1 in 200 years (l/s):	172.85	172.85

This report was produced using the greenfield runoff tool developed by HR Wallingford and available at [www.uksuds.com](http://www.uksuds.com). The use of this tool is subject to the UK SuDS terms and conditions and licence agreement, which can both be found at [www.uksuds.com/terms-and-conditions.htm](http://www.uksuds.com/terms-and-conditions.htm). The outputs from this tool are estimates of greenfield runoff rates. The use of these results is the responsibility of the users of this tool. No liability will be accepted by HR Wallingford, the Environment Agency, CEH, Hydrosolutions or any other organisation for the use of this data in the design or operational characteristics of any drainage scheme.



Calculated by:

Site name:

Site location:

## Site Details

Latitude:

Longitude:

Reference:

Date:

This is an estimation of the greenfield runoff rates that are used to meet normal best practice criteria in line with Environment Agency guidance "Rainfall runoff management for developments", SC030219 (2013), the SuDS Manual C753 (Ciria, 2015) and the non-statutory standards for SuDS (Defra, 2015). This information on greenfield runoff rates may be the basis for setting consents for the drainage of surface water runoff from sites.

## Runoff estimation approach

FEH Statistical

## Site characteristics

Total site area (ha):

## Methodology

$Q_{MED}$  estimation method:

BFI and SPR method:

HOST class:

BFI / BFIHOST:

$Q_{MED}$  (l/s):

$Q_{BAR}$  /  $Q_{MED}$  factor:

## Notes

### (1) Is $Q_{BAR} < 2.0$ l/s/ha?

When  $Q_{BAR}$  is  $< 2.0$  l/s/ha then limiting discharge rates are set at 2.0 l/s/ha.

### (2) Are flow rates $< 5.0$ l/s?

Where flow rates are less than 5.0 l/s consent for discharge is usually set at 5.0 l/s if blockage from vegetation and other materials is possible. Lower consent flow rates may be set where the blockage risk is addressed by using appropriate drainage elements.

### (3) Is $SPR/SPRHOST \leq 0.3$ ?

Where groundwater levels are low enough the use of soakaways to avoid discharge offsite would normally be preferred for disposal of surface water runoff.

## Hydrological characteristics

	Default	Edited
SAAR (mm):	579	579
Hydrological region:	5	5
Growth curve factor 1 year:	0.87	0.87
Growth curve factor 30 years:	2.45	2.45
Growth curve factor 100 years:	3.56	3.56
Growth curve factor 200 years:	4.21	4.21

## Greenfield runoff rates

	Default	Edited
$Q_{BAR}$ (l/s):	16.97	16.97
1 in 1 year (l/s):	14.76	14.76
1 in 30 years (l/s):	41.57	41.57
1 in 100 year (l/s):	60.41	60.41
1 in 200 years (l/s):	71.44	71.44

This report was produced using the greenfield runoff tool developed by HR Wallingford and available at www.uksuds.com. The use of this tool is subject to the UK SuDS terms and conditions and licence agreement, which can both be found at www.uksuds.com/terms-and-conditions.htm. The outputs from this tool are estimates of greenfield runoff rates. The use of these results is the responsibility of the users of this tool. No liability will be accepted by HR Wallingford, the Environment Agency, CEH, Hydrosolutions or any other organisation for the use of this data in the design or operational characteristics of any drainage scheme.

**APPENDIX E**  
**ATTENUATION STORAGE CALCULATIONS**

Table E1

Calculation of attenuation storage during a 1 in 100 year storm event plus an allowance for climate change for the attenuation basin C1 catchment using the Rational Method (reference 1)

Parameter	Value	Units	Reference
Catchment area	20	ha	Derived consistent with Section 5 and as shown on Figure 5.
Discharge rate	4320	m <sup>3</sup> /day	Permitted discharge limit (2007 SWMP)
Runoff coefficient	0.62	unitless	The runoff coefficient has been calculated using the nomogram presented on Figure 3 of Reference 1. In deriving the runoff coefficient a dominant vegetation type of cultivated land or short grass has been assumed and dominant soil type of clay/loam has been assumed. The slope is derived based on the catchment.
Climate change factor	40%	unitless	The recommended upper end increase in rainfall intensity to allow for climate change for 2085 to 2115 (reference 3) to test the sensitivity of the design and additional mitigation.

Storm Duration (hr)	Rainfall for the site derived from reference 2 (mm)	Rainfall Intensity corrected for climate change (mm/hr)	Volume of rainfall runoff in time period (m <sup>3</sup> )	Outflow in time period (m <sup>3</sup> )	Storage necessary in time period (m <sup>3</sup> )
0.25	29.69	166.26	5208.98	45.00	5164
0.5	38.79	108.61	6805.54	90.00	6716
0.75	44.39	82.86	7788.03	135.00	7653
1	48.39	67.75	8489.82	180.00	8310
1.5	54.55	50.91	9570.56	270.00	9301
2	59.39	41.57	10419.72	360.00	10060
3	67.22	31.37	11793.46	540.00	11253
4	73.3	25.66	12860.17	720.00	12140
5	78.18	21.89	13716.34	900.00	12816
6	82.2	19.18	14421.63	1080.00	13342
7	85.57	17.11	15012.89	1260.00	13753
8	88.42	15.47	15512.91	1440.00	14073
9	90.88	14.14	15944.50	1620.00	14325
10	93.02	13.02	16319.96	1800.00	14520
15	100.66	9.39	17660.36	2700.00	14960
15.25	100.94	9.27	17709.49	2745.00	14964
15.5	101.22	9.14	17758.61	2790.00	14969
15.75	101.5	9.02	17807.74	2835.00	14973
16	101.76	8.90	17853.35	2880.00	14973
16.25	102.02	8.79	17898.97	2925.00	14974
16.5	102.28	8.68	17944.58	2970.00	14975
16.75	102.52	8.57	17986.69	3015.00	14972
17	102.77	8.46	18030.55	3060.00	14971
18	103.69	8.06	18191.96	3240.00	14952
19	104.52	7.70	18337.58	3420.00	14918
20	105.28	7.37	18470.92	3600.00	14871
24	107.8	6.29	18913.04	4320.00	14593
30	110.48	5.16	19383.24	5400.00	13983
40	113.5	3.97	19913.08	7200.00	12713
50	115.52	3.23	20267.48	9000.00	11267
60	116.92	2.73	20513.11	10800.00	9713
70	118.12	2.36	20723.64	12600.00	8124
80	119.18	2.09	20909.62	14400.00	6510
90	120.15	1.87	21079.80	16200.00	4880
96	120.71	1.76	21178.05	17280.00	3898

<b>Maximum storage volume</b>	<b>14975</b> m <sup>3</sup>
<b>Critical Storm Period</b>	<b>16.5</b> hr

References

- Reference 1. National Coal Board, 1982. Technical Management of Water in the Coal Mining Industry.
- Reference 2. The Institute of Hydrology, 1999. Flood Estimation Handbook.
- Reference 3. <https://www.gov.uk/guidance/flood-and-coastal-risk-projects-schemes-and-strategies-climate-change-allowances#peak-rainfall-intensity-allowances>

Denotes parameters which are determined based on the restoration scheme, rainfall data or other constraints on discharge or water levels

Denotes parameters which are calculated based on other parameters

Table E2

Calculation of attenuation storage during a 1 in 30 year storm event plus an allowance for climate change for the attenuation basin C1 catchment using the Rational Method (reference 1)

Parameter	Value	Units	Reference
Catchment area	20	ha	Derived consistent with Section 5 and as shown on Figure 5.
Discharge rate	4320	m <sup>3</sup> /day	Permitted discharge limit (2007 SWMP)
Runoff coefficient	0.62	unitless	The runoff coefficient has been calculated using the nomogram presented on Figure 3 of Reference 1. In deriving the runoff coefficient a dominant vegetation type of cultivated land or short grass has been assumed and dominant soil type of clay/loam has been assumed. The slope is derived based on the catchment.
Climate change factor	20%	unitless	The recommended precautionary increase in rainfall intensity to allow for climate change for 2085 to 2115 (reference 3).

Storm Duration (hr)	Rainfall for the site derived from reference 2 (mm)	Rainfall Intensity corrected for climate change (mm/hr)	Volume of rainfall run off in time period (m <sup>3</sup> )	Outflow in time period (m <sup>3</sup> )	Storage necessary in time period (m <sup>3</sup> )
0.25	22.02	105.70	3311.41	45.00	3266
0.5	28.64	68.74	4306.94	90.00	4217
0.75	32.51	52.02	4888.92	135.00	4754
1	35.48	42.58	5335.55	180.00	5156
1.5	39.85	31.88	5992.72	270.00	5723
2	43.22	25.93	6499.51	360.00	6140
3	48.66	19.46	7317.59	540.00	6778
4	52.92	15.88	7958.22	720.00	7238
5	56.41	13.54	8483.05	900.00	7583
6	59.35	11.87	8925.17	1080.00	7845
7	61.91	10.61	9310.15	1260.00	8050
8	64.12	9.62	9642.49	1440.00	8202
9	66.05	8.81	9932.73	1620.00	8313
10	67.76	8.13	10189.88	1800.00	8390
11	69.28	7.56	10418.47	1980.00	8438
12	70.63	7.06	10621.48	2160.00	8461
12.25	70.95	6.95	10669.60	2205.00	8465
12.5	71.25	6.84	10714.72	2250.00	8465
12.75	71.55	6.73	10759.83	2295.00	8465
13	71.84	6.63	10803.44	2340.00	8463
13.25	72.12	6.53	10845.55	2385.00	8461
13.5	72.39	6.43	10886.15	2430.00	8456
13.75	72.66	6.34	10926.76	2475.00	8452
14	72.92	6.25	10965.86	2520.00	8446
15	73.91	5.91	11114.73	2700.00	8415
20	77.72	4.66	11687.69	3600.00	8088
30	82.24	3.29	12367.42	5400.00	6967
35	83.8	2.87	12602.01	6300.00	6302
40	85.11	2.55	12799.01	7200.00	5599
50	87.23	2.09	13117.82	9000.00	4118
60	88.87	1.78	13364.45	10800.00	2564
70	90.33	1.55	13584.01	12600.00	984
80	91.69	1.38	13788.53	14400.00	-611
85	92.34	1.30	13886.27	15300.00	-1414
86	92.47	1.29	13905.82	15480.00	-1574
87	92.6	1.28	13925.37	15660.00	-1735
87.25	92.63	1.27	13929.88	15705.00	-1775

<b>Maximum storage volume</b>	<b>8465</b> m <sup>3</sup>
<b>Critical Storm Period</b>	<b>12.75</b> hr

#### References

Reference 1. National Coal Board, 1982. Technical Management of Water in the Coal Mining Industry.

Reference 2. The Institute of Hydrology, 1999. Flood Estimation Handbook.

Reference 3. <https://www.gov.uk/guidance/flood-and-coastal-risk-projects-schemes-and-strategies-climate-change-allowances#peak-rainfall-intensity-allowances>

Denotes parameters which are determined based on the restoration scheme, rainfall data or other constraints on discharge or water levels

Denotes parameters which are calculated based on other parameters

Table E3

Calculation of attenuation storage during a 1 in 100 year storm event plus an allowance for climate change for the attenuation basin C2 catchment using the Rational Method (reference 1)

Parameter	Value	Units	Reference
Catchment area	6	ha	Derived consistent with Section 5 and as shown on Figure 5.
Discharge rate	1053	m <sup>3</sup> /day	QBAR (2l/s/ha)
Runoff coefficient	0.66	unitless	The runoff coefficient has been calculated using the nomogram presented on Figure 3 of Reference 1. In deriving the runoff coefficient a dominant vegetation type of cultivated land or short grass has been assumed and dominant soil type of clay/loam has been assumed. The slope is derived based on the catchment.
Climate change factor	40%	unitless	The recommended upper end increase in rainfall intensity to allow for climate change for 2085 to 2115 (reference 3) to test the sensitivity of the design and additional mitigation.

Storm Duration (hr)	Rainfall for the site derived from reference 2 (mm)	Rainfall Intensity corrected for climate change (mm/hr)	Volume of rainfall runoff in time period (m <sup>3</sup> )	Outflow in time period (m <sup>3</sup> )	Storage necessary in time period (m <sup>3</sup> )
0.25	29.69	166.26	1668.60	10.97	1658
0.5	38.79	108.61	2180.03	21.94	2158
0.75	44.39	82.86	2494.75	32.91	2462
1	48.39	67.75	2719.56	43.88	2676
1.5	54.55	50.91	3065.75	65.82	3000
2	59.39	41.57	3337.76	87.76	3250
3	67.22	31.37	3777.82	131.64	3646
4	73.3	25.66	4119.52	175.52	3944
5	78.18	21.89	4393.78	219.40	4174
6	82.2	19.18	4619.70	263.28	4356
7	85.57	17.11	4809.10	307.16	4502
8	88.42	15.47	4969.27	351.04	4618
9	90.88	14.14	5107.53	394.92	4713
10	93.02	13.02	5227.80	438.80	4789
15	100.66	9.39	5657.17	658.21	4999
16	101.76	8.90	5718.99	702.09	5017
17	102.77	8.46	5775.75	745.97	5030
18	103.69	8.06	5827.46	789.85	5038
19	104.52	7.70	5874.10	833.73	5040
19.25	104.71	7.62	5884.78	844.70	5040
19.5	104.9	7.53	5895.46	855.67	5040
19.75	105.09	7.45	5906.14	866.64	5040
20	105.28	7.37	5916.82	877.61	5039
20.25	105.46	7.29	5926.93	888.58	5038
20.5	105.63	7.21	5936.49	899.55	5037
20.75	105.81	7.14	5946.60	910.52	5036
21	105.98	7.07	5956.16	921.49	5035
22	106.63	6.79	5992.69	965.37	5027
23	107.23	6.53	6026.41	1009.25	5017
24	107.8	6.29	6058.44	1053.13	5005
25	108.31	6.07	6087.11	1097.01	4990
30	110.48	5.16	6209.06	1316.41	4893
35	112.15	4.49	6302.92	1535.81	4767
40	113.5	3.97	6378.79	1755.22	4624
50	115.52	3.23	6492.31	2194.02	4298
60	116.92	2.73	6570.99	2632.82	3938
70	118.12	2.36	6638.43	3071.63	3567
80	119.18	2.09	6698.01	3510.43	3188
90	120.15	1.87	6752.52	3949.24	2803
96	120.71	1.76	6783.99	4212.52	2571

<b>Maximum storage volume</b>	<b>5040</b> m <sup>3</sup>
<b>Critical Storm Period</b>	<b>19</b> hr

References

- Reference 1. National Coal Board, 1982. Technical Management of Water in the Coal Mining Industry.
- Reference 2. The Institute of Hydrology, 1999. Flood Estimation Handbook.
- Reference 3. <https://www.gov.uk/guidance/flood-and-coastal-risk-projects-schemes-and-strategies-climate-change-allowances#peak-rainfall-intensity-allowances>

Denotes parameters which are determined based on the restoration scheme, rainfall data or other constraints on discharge or water levels  
 Denotes parameters which are calculated based on other parameters

Table E4

Calculation of attenuation storage during a 1 in 30 year storm event plus an allowance for climate change for the attenuation basin C2 catchment using the Rational Method (reference 1)

Parameter	Value	Units	Reference
Catchment area	6	ha	Derived consistent with Section 5 and as shown on Figure 5.
Discharge rate	1053	m <sup>3</sup> /day	QBAR (2l/s/ha)
Runoff coefficient	0.66	unitless	The runoff coefficient has been calculated using the nomogram presented on Figure 3 of Reference 1. In deriving the runoff coefficient a dominant vegetation type of cultivated land or short grass has been assumed and dominant soil type of clay/loam has been assumed. The slope is derived based on the catchment.
Climate change factor	20%	unitless	The recommended precautionary increase in rainfall intensity to allow for climate change for 2085 to 2115 (reference 3).

Storm Duration (hr)	Rainfall for the site derived from reference 2 (mm)	Rainfall Intensity corrected for climate change (mm/hr)	Volume of rainfall run off in time period (m <sup>3</sup> )	Outflow in time period (m <sup>3</sup> )	Storage necessary in time period (m <sup>3</sup> )
0.25	22.02	105.70	1060.75	10.97	1050
0.5	28.64	68.74	1379.65	21.94	1358
0.75	32.51	52.02	1566.07	32.91	1533
1	35.48	42.58	1709.15	43.88	1665
1.5	39.85	31.88	1919.66	65.82	1854
2	43.22	25.93	2082.00	87.76	1994
3	48.66	19.46	2344.05	131.64	2212
4	52.92	15.88	2549.27	175.52	2374
5	56.41	13.54	2717.39	219.40	2498
6	59.35	11.87	2859.01	263.28	2596
7	61.91	10.61	2982.33	307.16	2675
8	64.12	9.62	3088.79	351.04	2738
9	66.05	8.81	3181.77	394.92	2787
10	67.76	8.13	3264.14	438.80	2825
15	73.91	5.91	3560.40	658.21	2902
15.25	74.14	5.83	3571.48	669.18	2902
15.5	74.37	5.76	3582.56	680.15	2902
15.75	74.59	5.68	3593.16	691.12	2902
16	74.81	5.61	3603.75	702.09	2902
16.25	75.02	5.54	3613.87	713.06	2901
16.5	75.23	5.47	3623.99	724.03	2900
16.75	75.43	5.40	3633.62	735.00	2899
17	75.63	5.34	3643.25	745.97	2897
18	76.39	5.09	3679.87	789.85	2890
19	77.08	4.87	3713.10	833.73	2879
20	77.72	4.66	3743.93	877.61	2866
30	82.24	3.29	3961.67	1316.41	2645
40	85.11	2.55	4099.93	1755.22	2345
50	87.23	2.09	4202.05	2194.02	2008
60	88.87	1.78	4281.05	2632.82	1648
70	90.33	1.55	4351.38	3071.63	1280
80	91.69	1.38	4416.90	3510.43	906
90	92.98	1.24	4479.04	3949.24	530
96	93.73	1.17	4515.17	4212.52	303

<b>Maximum storage volume</b>	<b>2902</b> m <sup>3</sup>
<b>Critical Storm Period</b>	<b>15.5</b> hr

#### References

Reference 1. National Coal Board, 1982. Technical Management of Water in the Coal Mining Industry.

Reference 2. The Institute of Hydrology, 1999. Flood Estimation Handbook.

Reference 3. <https://www.gov.uk/guidance/flood-and-coastal-risk-projects-schemes-and-strategies-climate-change-allowances#peak-rainfall-intensity-allowances>

Denotes parameters which are determined based on the restoration scheme, rainfall data or other constraints on discharge or water levels

Denotes parameters which are calculated based on other parameters

Table E5

Calculation of attenuation storage during a 1 in 100 year storm event plus an allowance for climate change for the attenuation basin C3 catchment using the Rational Method (reference 1)

Parameter	Value	Units	Reference
Catchment area	8	ha	Derived consistent with Section 5 and as shown on Figure 5.
Discharge rate	1421	m <sup>3</sup> /day	QBAR (2l/s/ha)
Runoff coefficient	0.64	unitless	The runoff coefficient has been calculated using the nomogram presented on Figure 3 of Reference 1. In deriving the runoff coefficient a dominant vegetation type of cultivated land or short grass has been assumed and dominant soil type of clay/loam has been assumed. The slope is derived based on the catchment.
Climate change factor	40%	unitless	The recommended upper end increase in rainfall intensity to allow for climate change for 2085 to 2115 (reference 3) to test the sensitivity of the design and additional mitigation.

Storm Duration (hr)	Rainfall for the site derived from reference 2 (mm)	Rainfall Intensity corrected for climate change (mm/hr)	Volume of rainfall runoff in time period (m <sup>3</sup> )	Outflow in time period (m <sup>3</sup> )	Storage necessary in time period (m <sup>3</sup> )
0.25	29.69	166.26	2199.74	14.80	2185
0.5	38.79	108.61	2873.96	29.60	2844
0.75	44.39	82.86	3288.87	44.40	3244
1	48.39	67.75	3585.23	59.21	3526
1.5	54.55	50.91	4041.63	88.81	3953
2	59.39	41.57	4400.22	118.41	4282
3	67.22	31.37	4980.35	177.62	4803
4	73.3	25.66	5430.82	236.82	5194
5	78.18	21.89	5792.38	296.03	5496
6	82.2	19.18	6090.22	355.23	5735
7	85.57	17.11	6339.91	414.44	5925
8	88.42	15.47	6551.06	473.64	6077
9	90.88	14.14	6733.33	532.85	6200
10	93.02	13.02	6891.88	592.06	6300
15	100.66	9.39	7457.93	888.08	6570
16	101.76	8.90	7539.43	947.29	6592
17	102.77	8.46	7614.26	1006.50	6608
18	103.69	8.06	7682.42	1065.70	6617
18.5	104.11	7.88	7713.54	1095.30	6618
19	104.52	7.70	7743.92	1124.91	6619
19.25	104.71	7.62	7758.00	1139.71	6618
19.5	104.9	7.53	7772.07	1154.51	6618
19.75	105.09	7.45	7786.15	1169.31	6617
20	105.28	7.37	7800.23	1184.11	6616
25	108.31	6.07	8024.72	1480.14	6545
30	110.48	5.16	8185.50	1776.17	6409
40	113.5	3.97	8409.25	2368.22	6041
50	115.52	3.23	8558.91	2960.28	5599
60	116.92	2.73	8662.64	3552.34	5110
70	118.12	2.36	8751.55	4144.39	4607
80	119.18	2.09	8830.08	4736.45	4094
90	120.15	1.87	8901.95	5328.50	3573
96	120.71	1.76	8943.44	5683.74	3260

<b>Maximum storage volume</b>	<b>6619</b> m <sup>3</sup>
<b>Critical Storm Period</b>	<b>19</b> hr

#### References

- Reference 1. National Coal Board, 1982. Technical Management of Water in the Coal Mining Industry.  
 Reference 2. The Institute of Hydrology, 1999. Flood Estimation Handbook.  
 Reference 3. <https://www.gov.uk/guidance/flood-and-coastal-risk-projects-schemes-and-strategies-climate-change-allowances#peak-rainfall-intensity-allowances>

Denotes parameters which are determined based on the restoration scheme, rainfall data or other constraints on discharge or water levels

Denotes parameters which are calculated based on other parameters

Table E6

Calculation of attenuation storage during a 1 in 30 year storm event plus an allowance for climate change for the attenuation basin C3 catchment using the Rational Method (reference 1)

Parameter	Value	Units	Reference
Catchment area	8	ha	Derived consistent with Section 5 and as shown on Figure 5.
Discharge rate	1421	m <sup>3</sup> /day	QBAR (2l/s/ha)
Runoff coefficient	0.64	unitless	The runoff coefficient has been calculated using the nomogram presented on Figure 3 of Reference 1. In deriving the runoff coefficient a dominant vegetation type of cultivated land or short grass has been assumed and dominant soil type of clay/loam has been assumed. The slope is derived based on the catchment.
Climate change factor	20%	unitless	The recommended precautionary increase in rainfall intensity to allow for climate change for 2085 to 2115 (reference 3).

Storm Duration (hr)	Rainfall for the site derived from reference 2 (mm)	Rainfall Intensity corrected for climate change (mm/hr)	Volume of rainfall runoff in time period (m <sup>3</sup> )	Outflow in time period (m <sup>3</sup> )	Storage necessary in time period (m <sup>3</sup> )
0.25	22.02	105.70	1398.40	14.80	1384
0.5	28.64	68.74	1818.81	29.60	1789
0.75	32.51	52.02	2064.58	44.40	2020
1	35.48	42.58	2253.19	59.21	2194
1.5	39.85	31.88	2530.71	88.81	2442
2	43.22	25.93	2744.73	118.41	2626
3	48.66	19.46	3090.20	177.62	2913
4	52.92	15.88	3360.74	236.82	3124
5	56.41	13.54	3582.37	296.03	3286
6	59.35	11.87	3769.08	355.23	3414
7	61.91	10.61	3931.65	414.44	3517
8	64.12	9.62	4072.00	473.64	3598
9	66.05	8.81	4194.57	532.85	3662
10	67.76	8.13	4303.16	592.06	3711
11	69.28	7.56	4399.69	651.26	3748
12	70.63	7.06	4485.43	710.47	3775
13	71.84	6.63	4562.27	769.67	3793
14	72.92	6.25	4630.86	828.88	3802
14.5	73.42	6.08	4662.61	858.48	3804
14.75	73.67	5.99	4678.49	873.28	3805
15	73.91	5.91	4693.73	888.08	3806
15.5	74.37	5.76	4722.94	917.69	3805
16	74.81	5.61	4750.88	947.29	3804
17	75.63	5.34	4802.96	1006.50	3796
18	76.39	5.09	4851.22	1065.70	3786
19	77.08	4.87	4895.04	1124.91	3770
20	77.72	4.66	4935.68	1184.11	3752
30	82.24	3.29	5222.73	1776.17	3447
40	85.11	2.55	5404.99	2368.22	3037
50	87.23	2.09	5539.63	2960.28	2579
60	88.87	1.78	5643.78	3552.34	2091
70	90.33	1.55	5736.49	4144.39	1592
80	91.69	1.38	5822.86	4736.45	1086
90	92.98	1.24	5904.79	5328.50	576
96	93.73	1.17	5952.41	5683.74	269

<b>Maximum storage volume</b>	<b>3806</b> m <sup>3</sup>
<b>Critical Storm Period</b>	<b>15</b> hr

References

- Reference 1. National Coal Board, 1982. Technical Management of Water in the Coal Mining Industry.
- Reference 2. The Institute of Hydrology, 1999. Flood Estimation Handbook.
- Reference 3. <https://www.gov.uk/guidance/flood-and-coastal-risk-projects-schemes-and-strategies-climate-change-allowances#peak-rainfall-intensity-allowances>

Denotes parameters which are determined based on the restoration scheme, rainfall data or other constraints on discharge or water levels

Denotes parameters which are calculated based on other parameters



Table E7

Calculation of attenuation storage during a 1 in 100 year storm event plus an allowance for climate change for the attenuation basin C4 catchment using the Rational Method (reference 1)

Parameter	Value	Units	Reference
Catchment area	3	ha	Derived consistent with Section 5 and as shown on Figure 5.
Discharge rate	480	m <sup>3</sup> /day	QBAR (2l/s/ha)
Runoff coefficient	0.66	unitless	The runoff coefficient has been calculated using the nomogram presented on Figure 3 of Reference 1. In deriving the runoff coefficient a dominant vegetation type of cultivated land or short grass has been assumed and dominant soil type of clay/loam has been assumed. The slope is derived based on the catchment.
Climate change factor	40%	unitless	The recommended upper end increase in rainfall intensity to allow for climate change for 2085 to 2115 (reference 3) to test the sensitivity of the design and additional mitigation.

Storm Duration (hr)	Rainfall for the site derived from reference 2 (mm)	Rainfall Intensity corrected for climate change (mm/hr)	Volume of rainfall runoff in time period (m <sup>3</sup> )	Outflow in time period (m <sup>3</sup> )	Storage necessary in time period (m <sup>3</sup> )
0.25	29.69	166.26	756.64	5.00	752
0.5	38.79	108.61	988.55	9.99	979
0.75	44.39	82.86	1131.27	14.99	1116
1	48.39	67.75	1233.21	19.98	1213
1.5	54.55	50.91	1390.19	29.97	1360
2	59.39	41.57	1513.54	39.96	1474
3	67.22	31.37	1713.09	59.94	1653
4	73.3	25.66	1868.03	79.92	1788
5	78.18	21.89	1992.40	99.90	1892
6	82.2	19.18	2094.85	119.88	1975
7	85.57	17.11	2180.73	139.86	2041
8	88.42	15.47	2253.36	159.84	2094
9	90.88	14.14	2316.06	179.82	2136
10	93.02	13.02	2370.59	199.80	2171
15	100.66	9.39	2565.30	299.70	2266
16	101.76	8.90	2593.33	319.68	2274
17	102.77	8.46	2619.07	339.66	2279
18	103.69	8.06	2642.52	359.64	2283
18.5	104.11	7.88	2653.22	369.63	2284
19	104.52	7.70	2663.67	379.62	2284
19.5	104.9	7.53	2673.35	389.61	2284
20	105.28	7.37	2683.04	399.60	2283
21	105.98	7.07	2700.88	419.58	2281
22	106.63	6.79	2717.44	439.56	2278
23	107.23	6.53	2732.73	459.54	2273
24	107.8	6.29	2747.26	479.52	2268
25	108.31	6.07	2760.25	499.50	2261
30	110.48	5.16	2815.56	599.40	2216
40	113.5	3.97	2892.52	799.20	2093
50	115.52	3.23	2944.00	999.00	1945
60	116.92	2.73	2979.68	1198.80	1781
70	118.12	2.36	3010.26	1398.60	1612
80	119.18	2.09	3037.27	1598.40	1439
90	120.15	1.87	3061.99	1798.20	1264
96	120.71	1.76	3076.27	1918.08	1158

<b>Maximum storage volume</b>	<b>2284</b> m <sup>3</sup>
<b>Critical Storm Period</b>	<b>19</b> hr

References

- Reference 1. National Coal Board, 1982. Technical Management of Water in the Coal Mining Industry.
- Reference 2. The Institute of Hydrology, 1999. Flood Estimation Handbook.
- Reference 3. <https://www.gov.uk/guidance/flood-and-coastal-risk-projects-schemes-and-strategies-climate-change-allowances#peak-rainfall-intensity-allowances>

Denotes parameters which are determined based on the restoration scheme, rainfall data or other constraints on discharge or water levels

Denotes parameters which are calculated based on other parameters

Table E8

Calculation of attenuation storage during a 1 in 30 year storm event plus an allowance for climate change for the attenuation basin C4 catchment using the Rational Method (reference 1)

Parameter	Value	Units	Reference
Catchment area	3	ha	Derived consistent with Section 5 and as shown on Figure 5.
Discharge rate	480	m <sup>3</sup> /day	QBAR (2l/s/ha)
Runoff coefficient	0.66	unitless	The runoff coefficient has been calculated using the nomogram presented on Figure 3 of Reference 1. In deriving the runoff coefficient a dominant vegetation type of cultivated land or short grass has been assumed and dominant soil type of clay/loam has been assumed. The slope is derived based on the catchment.
Climate change factor	20%	unitless	The recommended precautionary increase in rainfall intensity to allow for climate change for 2085 to 2115 (reference 3).

Storm Duration (hr)	Rainfall for the site derived from reference 2 (mm)	Rainfall Intensity corrected for climate change (mm/hr)	Volume of rainfall run off in time period (m <sup>3</sup> )	Outflow in time period (m <sup>3</sup> )	Storage necessary in time period (m <sup>3</sup> )
0.25	22.02	105.70	481.01	5.00	476
0.5	28.64	68.74	625.61	9.99	616
0.75	32.51	52.02	710.15	14.99	695
1	35.48	42.58	775.03	19.98	755
1.5	39.85	31.88	870.49	29.97	841
2	43.22	25.93	944.10	39.96	904
3	48.66	19.46	1062.93	59.94	1003
4	52.92	15.88	1155.99	79.92	1076
5	56.41	13.54	1232.22	99.90	1132
6	59.35	11.87	1296.45	119.88	1177
7	61.91	10.61	1352.37	139.86	1213
8	64.12	9.62	1400.64	159.84	1241
9	66.05	8.81	1442.80	179.82	1263
10	67.76	8.13	1480.16	199.80	1280
11	69.28	7.56	1513.36	219.78	1294
12	70.63	7.06	1542.85	239.76	1303
13	71.84	6.63	1569.28	259.74	1310
14	72.92	6.25	1592.87	279.72	1313
14.5	73.42	6.08	1603.79	289.71	1314
15	73.91	5.91	1614.50	299.70	1315
15.5	74.37	5.76	1624.54	309.69	1315
16	74.81	5.61	1634.16	319.68	1314
16.5	75.23	5.47	1643.33	329.67	1314
17	75.63	5.34	1652.07	339.66	1312
18	76.39	5.09	1668.67	359.64	1309
19	77.08	4.87	1683.74	379.62	1304
20	77.72	4.66	1697.72	399.60	1298
30	82.24	3.29	1796.46	599.40	1197
40	85.11	2.55	1859.15	799.20	1060
50	87.23	2.09	1905.46	999.00	906
60	88.87	1.78	1941.28	1198.80	742
70	90.33	1.55	1973.18	1398.60	575
80	91.69	1.38	2002.88	1598.40	404
90	92.98	1.24	2031.06	1798.20	233
96	93.73	1.17	2047.45	1918.08	129

<b>Maximum storage volume</b>	<b>1315</b> m <sup>3</sup>
<b>Critical Storm Period</b>	<b>15.5</b> hr

#### References

Reference 1. National Coal Board, 1982. Technical Management of Water in the Coal Mining Industry.

Reference 2. The Institute of Hydrology, 1999. Flood Estimation Handbook.

Reference 3. <https://www.gov.uk/guidance/flood-and-coastal-risk-projects-schemes-and-strategies-climate-change-allowances#peak-rainfall-intensity-allowances>

Denotes parameters which are determined based on the restoration scheme, rainfall data or other constraints on discharge or water levels

Denotes parameters which are calculated based on other parameters

Table E9

Calculation of attenuation storage during a 1 in 100 year storm event plus an allowance for climate change for the attenuation basin C5 catchment using the Rational Method (reference 1)

Parameter	Value	Units	Reference
Catchment area	6	ha	Derived consistent with Section 5 and as shown on Figure 5.
Discharge rate	1021	m <sup>3</sup> /day	QBAR (2l/s/ha)
Runoff coefficient	0.64	unitless	The runoff coefficient has been calculated using the nomogram presented on Figure 3 of Reference 1. In deriving the runoff coefficient a dominant vegetation type of cultivated land or short grass has been assumed and dominant soil type of clay/loam has been assumed. The slope is derived based on the catchment.
Climate change factor	40%	unitless	The recommended upper end increase in rainfall intensity to allow for climate change for 2085 to 2115 (reference 3) to test the sensitivity of the design and additional mitigation.

Storm Duration (hr)	Rainfall for the site derived from reference 2 (mm)	Rainfall Intensity corrected for climate change (mm/hr)	Volume of rainfall runoff in time period (m <sup>3</sup> )	Outflow in time period (m <sup>3</sup> )	Storage necessary in time period (m <sup>3</sup> )
0.25	29.69	166.26	1565.54	10.63	1555
0.5	38.79	108.61	2045.37	21.27	2024
0.75	44.39	82.86	2340.66	31.90	2309
1	48.39	67.75	2551.58	42.54	2509
1.5	54.55	50.91	2876.39	63.81	2813
2	59.39	41.57	3131.60	85.08	3047
3	67.22	31.37	3544.47	127.61	3417
4	73.3	25.66	3865.07	170.15	3695
5	78.18	21.89	4122.39	212.69	3910
6	82.2	19.18	4334.36	255.23	4079
7	85.57	17.11	4512.06	297.76	4214
8	88.42	15.47	4662.34	340.30	4322
9	90.88	14.14	4792.05	382.84	4409
10	93.02	13.02	4904.89	425.38	4480
15	100.66	9.39	5307.75	638.06	4670
16	101.76	8.90	5365.75	680.60	4685
17	102.77	8.46	5419.00	723.14	4696
18	103.69	8.06	5467.52	765.68	4702
19	104.52	7.70	5511.28	808.21	4703
19.25	104.71	7.62	5521.30	818.85	4702
19.5	104.9	7.53	5531.32	829.48	4702
19.75	105.09	7.45	5541.34	840.12	4701
20	105.28	7.37	5551.36	850.75	4701
20.25	105.46	7.29	5560.85	861.39	4699
20.5	105.63	7.21	5569.81	872.02	4698
21	105.98	7.07	5588.27	893.29	4695
21.5	106.31	6.92	5605.67	914.56	4691
22	106.63	6.79	5622.54	935.83	4687
23	107.23	6.53	5654.18	978.36	4676
24	107.8	6.29	5684.23	1020.90	4663
25	108.31	6.07	5711.13	1063.44	4648
30	110.48	5.16	5825.55	1276.13	4549
40	113.5	3.97	5984.79	1701.50	4283
50	115.52	3.23	6091.30	2126.88	3964
60	116.92	2.73	6165.13	2552.26	3613
70	118.12	2.36	6228.40	2977.63	3251
80	119.18	2.09	6284.29	3403.01	2881
90	120.15	1.87	6335.44	3828.38	2507
96	120.71	1.76	6364.97	4083.61	2281

<b>Maximum storage volume</b>	<b>4703</b> m <sup>3</sup>
<b>Critical Storm Period</b>	<b>19</b> hr

References

- Reference 1. National Coal Board, 1982. Technical Management of Water in the Coal Mining Industry.
- Reference 2. The Institute of Hydrology, 1999. Flood Estimation Handbook.
- Reference 3. <https://www.gov.uk/guidance/flood-and-coastal-risk-projects-schemes-and-strategies-climate-change-allowances#peak-rainfall-intensity-allowances>

Denotes parameters which are determined based on the restoration scheme, rainfall data or other constraints on discharge or water levels  
 Denotes parameters which are calculated based on other parameters

Table E10

Calculation of attenuation storage during a 1 in 30 year storm event plus an allowance for climate change for the attenuation basin C5 catchment using the Rational Method (reference 1)

Parameter	Value	Units	Reference
Catchment area	6	ha	Derived consistent with Section 5 and as shown on Figure 5.
Discharge rate	1021	m <sup>3</sup> /day	QBAR (2l/s/ha)
Runoff coefficient	0.64	unitless	The runoff coefficient has been calculated using the nomogram presented on Figure 3 of Reference 1. In deriving the runoff coefficient a dominant vegetation type of cultivated land or short grass has been assumed and dominant soil type of clay/loam has been assumed. The slope is derived based on the catchment.
Climate change factor	20%	unitless	The recommended precautionary increase in rainfall intensity to allow for climate change for 2085 to 2115 (reference 3).

Storm Duration (hr)	Rainfall for the site derived from reference 2 (mm)	Rainfall Intensity corrected for climate change (mm/hr)	Volume of rainfall runoff in time period (m <sup>3</sup> )	Outflow in time period (m <sup>3</sup> )	Storage necessary in time period (m <sup>3</sup> )
0.25	22.02	105.70	995.23	10.63	985
0.5	28.64	68.74	1294.43	21.27	1273
0.75	32.51	52.02	1469.34	31.90	1437
1	35.48	42.58	1603.58	42.54	1561
1.5	39.85	31.88	1801.09	63.81	1737
2	43.22	25.93	1953.40	85.08	1868
3	48.66	19.46	2199.27	127.61	2072
4	52.92	15.88	2391.81	170.15	2222
5	56.41	13.54	2549.54	212.69	2337
6	59.35	11.87	2682.42	255.23	2427
7	61.91	10.61	2798.13	297.76	2500
8	64.12	9.62	2898.01	340.30	2558
9	66.05	8.81	2985.24	382.84	2602
10	67.76	8.13	3062.53	425.38	2637
11	69.28	7.56	3131.22	467.91	2663
12	70.63	7.06	3192.24	510.45	2682
13	71.84	6.63	3246.93	552.99	2694
14	72.92	6.25	3295.74	595.53	2700
14.5	73.42	6.08	3318.34	616.80	2702
15	73.91	5.91	3340.49	638.06	2702
15.5	74.37	5.76	3361.28	659.33	2702
15.75	74.59	5.68	3371.22	669.97	2701
16	74.81	5.61	3381.16	680.60	2701
16.25	75.02	5.54	3390.65	691.24	2699
16.5	75.23	5.47	3400.14	701.87	2698
16.75	75.43	5.40	3409.18	712.50	2697
17	75.63	5.34	3418.22	723.14	2695
17.5	76.02	5.21	3435.85	744.41	2691
18	76.39	5.09	3452.57	765.68	2687
19	77.08	4.87	3483.76	808.21	2676
20	77.72	4.66	3512.68	850.75	2662
25	80.33	3.86	3630.65	1063.44	2567
30	82.24	3.29	3716.97	1276.13	2441
40	85.11	2.55	3846.69	1701.50	2145
50	87.23	2.09	3942.50	2126.88	1816
60	88.87	1.78	4016.63	2552.26	1464
70	90.33	1.55	4082.61	2977.63	1105
80	91.69	1.38	4144.08	3403.01	741
90	92.98	1.24	4202.39	3828.38	374
96	93.73	1.17	4236.28	4083.61	153

<b>Maximum storage volume</b>	<b>2702</b> m <sup>3</sup>
<b>Critical Storm Period</b>	<b>15</b> hr

References

- Reference 1. National Coal Board, 1982. Technical Management of Water in the Coal Mining Industry.
- Reference 2. The Institute of Hydrology, 1999. Flood Estimation Handbook.
- Reference 3. <https://www.gov.uk/guidance/flood-and-coastal-risk-projects-schemes-and-strategies-climate-change-allowances#peak-rainfall-intensity-allowances>

Denotes parameters which are determined based on the restoration scheme, rainfall data or other constraints on discharge or water levels  
 Denotes parameters which are calculated based on other parameters

Table E11

Calculation of attenuation storage during a 1 in 100 year storm event plus an allowance for climate change for the attenuation basin C6 catchment using the Rational Method (reference 1)

Parameter	Value	Units	Reference
Catchment area	4	ha	Derived consistent with Section 5 and as shown on Figure 5.
Discharge rate	710	m <sup>3</sup> /day	QBAR (2l/s/ha)
Runoff coefficient	0.62	unitless	The runoff coefficient has been calculated using the nomogram presented on Figure 3 of Reference 1. In deriving the runoff coefficient a dominant vegetation type of cultivated land or short grass has been assumed and dominant soil type of clay/loam has been assumed. The slope is derived based on the catchment.
Climate change factor	40%	unitless	The recommended upper end increase in rainfall intensity to allow for climate change for 2085 to 2115 (reference 3) to test the sensitivity of the design and additional mitigation.

Storm Duration (hr)	Rainfall for the site derived from reference 2 (mm)	Rainfall Intensity corrected for climate change (mm/hr)	Volume of rainfall runoff in time period (m <sup>3</sup> )	Outflow in time period (m <sup>3</sup> )	Storage necessary in time period (m <sup>3</sup> )
0.25	29.69	166.26	1052.03	7.39	1045
0.5	38.79	108.61	1374.47	14.79	1360
0.75	44.39	82.86	1572.90	22.18	1551
1	48.39	67.75	1714.63	29.57	1685
1.5	54.55	50.91	1932.91	44.36	1889
2	59.39	41.57	2104.40	59.15	2045
3	67.22	31.37	2381.85	88.72	2293
4	73.3	25.66	2597.29	118.30	2479
5	78.18	21.89	2770.20	147.87	2622
6	82.2	19.18	2912.65	177.44	2735
7	85.57	17.11	3032.06	207.02	2825
8	88.42	15.47	3133.04	236.59	2896
9	90.88	14.14	3220.21	266.17	2954
10	93.02	13.02	3296.04	295.74	3000
15	100.66	9.39	3566.75	443.61	3123
16	101.76	8.90	3605.73	473.18	3133
17	102.77	8.46	3641.52	502.76	3139
17.5	103.24	8.26	3658.17	517.55	3141
18	103.69	8.06	3674.12	532.33	3142
18.5	104.11	7.88	3689.00	547.12	3142
18.75	104.31	7.79	3696.08	554.51	3142
19	104.52	7.70	3703.53	561.91	3142
19.25	104.71	7.62	3710.26	569.30	3141
19.5	104.9	7.53	3716.99	576.69	3140
20	105.28	7.37	3730.46	591.48	3139
21	105.98	7.07	3755.26	621.05	3134
22	106.63	6.79	3778.29	650.63	3128
23	107.23	6.53	3799.55	680.20	3119
24	107.8	6.29	3819.75	709.78	3110
25	108.31	6.07	3837.82	739.35	3098
30	110.48	5.16	3914.71	887.22	3027
35	112.15	4.49	3973.88	1035.09	2939
40	113.5	3.97	4021.72	1182.96	2839
50	115.52	3.23	4093.30	1478.70	2615
60	116.92	2.73	4142.90	1774.44	2368
70	118.12	2.36	4185.42	2070.18	2115
80	119.18	2.09	4222.98	2365.92	1857
90	120.15	1.87	4257.35	2661.66	1596
96	120.71	1.76	4277.20	2839.10	1438

<b>Maximum storage volume</b>	<b>3142</b> m <sup>3</sup>
<b>Critical Storm Period</b>	<b>18.5</b> hr

References

- Reference 1. National Coal Board, 1982. Technical Management of Water in the Coal Mining Industry.
- Reference 2. The Institute of Hydrology, 1999. Flood Estimation Handbook.
- Reference 3. <https://www.gov.uk/guidance/flood-and-coastal-risk-projects-schemes-and-strategies-climate-change-allowances#peak-rainfall-intensity-allowances>

Denotes parameters which are determined based on the restoration scheme, rainfall data or other constraints on discharge or water levels  
 Denotes parameters which are calculated based on other parameters

Table E12

Calculation of attenuation storage during a 1 in 30 year storm event plus an allowance for climate change for the attenuation basin C6 catchment using the Rational Method (reference 1)

Parameter	Value	Units	Reference
Catchment area	4	ha	Derived consistent with Section 5 and as shown on Figure 5.
Discharge rate	710	m <sup>3</sup> /day	QBAR (2l/s/ha)
Runoff coefficient	0.62	unitless	The runoff coefficient has been calculated using the nomogram presented on Figure 3 of Reference 1. In deriving the runoff coefficient a dominant vegetation type of cultivated land or short grass has been assumed and dominant soil type of clay/loam has been assumed. The slope is derived based on the catchment.
Climate change factor	20%	unitless	The recommended precautionary increase in rainfall intensity to allow for climate change for 2085 to 2115 (reference 3).

Storm Duration (hr)	Rainfall for the site derived from reference 2 (mm)	Rainfall Intensity corrected for climate change (mm/hr)	Volume of rainfall run off in time period (m <sup>3</sup> )	Outflow in time period (m <sup>3</sup> )	Storage necessary in time period (m <sup>3</sup> )
0.25	22.02	105.70	668.78	7.39	661
0.5	28.64	68.74	869.85	14.79	855
0.75	32.51	52.02	987.38	22.18	965
1	35.48	42.58	1077.59	29.57	1048
1.5	39.85	31.88	1210.31	44.36	1166
2	43.22	25.93	1312.67	59.15	1254
3	48.66	19.46	1477.89	88.72	1389
4	52.92	15.88	1607.27	118.30	1489
5	56.41	13.54	1713.27	147.87	1565
6	59.35	11.87	1802.56	177.44	1625
7	61.91	10.61	1880.31	207.02	1673
8	64.12	9.62	1947.43	236.59	1711
9	66.05	8.81	2006.05	266.17	1740
10	67.76	8.13	2057.99	295.74	1762
11	69.28	7.56	2104.15	325.31	1779
12	70.63	7.06	2145.15	354.89	1790
13	71.84	6.63	2181.90	384.46	1797
14	72.92	6.25	2214.70	414.04	1801
14.25	73.18	6.16	2222.60	421.43	1801
14.5	73.42	6.08	2229.89	428.82	1801
14.75	73.67	5.99	2237.48	436.22	1801
15	73.91	5.91	2244.77	443.61	1801
15.5	74.37	5.76	2258.74	458.40	1800
16	74.81	5.61	2272.11	473.18	1799
16.5	75.23	5.47	2284.86	487.97	1797
17	75.63	5.34	2297.01	502.76	1794
18	76.39	5.09	2320.09	532.33	1788
19	77.08	4.87	2341.05	561.91	1779
20	77.72	4.66	2360.49	591.48	1769
25	80.33	3.86	2439.76	739.35	1700
30	82.24	3.29	2497.77	887.22	1611
35	83.8	2.87	2545.15	1035.09	1510
40	85.11	2.55	2584.94	1182.96	1402
50	87.23	2.09	2649.32	1478.70	1171
60	88.87	1.78	2699.13	1774.44	925
70	90.33	1.55	2743.48	2070.18	673
80	91.69	1.38	2784.78	2365.92	419
90	92.98	1.24	2823.96	2661.66	162
91	93.1	1.23	2827.61	2691.23	136
92	93.23	1.22	2831.55	2720.81	111
93	93.36	1.20	2835.50	2750.38	85
94	93.48	1.19	2839.15	2779.96	59
95	93.61	1.18	2843.10	2809.53	34
96	93.73	1.17	2846.74	2839.10	8

<b>Maximum storage volume</b>	<b>1801</b> m <sup>3</sup>
<b>Critical Storm Period</b>	<b>14.75</b> hr

References

- Reference 1. National Coal Board, 1982. Technical Management of Water in the Coal Mining Industry.
- Reference 2. The Institute of Hydrology, 1999. Flood Estimation Handbook.
- Reference 3. <https://www.gov.uk/guidance/flood-and-coastal-risk-projects-schemes-and-strategies-climate-change-allowances#peak-rainfall-intensity-allowances>

Denotes parameters which are determined based on the restoration scheme, rainfall data or other constraints on discharge or water levels  
 Denotes parameters which are calculated based on other parameters

Table E13

Calculation of attenuation storage during a 1 in 100 year storm event plus an allowance for climate change for the attenuation basin C7 catchment using the Rational Method (reference 1)

Parameter	Value	Units	Reference
Catchment area	3	ha	Derived consistent with Section 5 and as shown on Figure 5.
Discharge rate	569	m <sup>3</sup> /day	QBAR (2l/s/ha)
Runoff coefficient	0.66	unitless	The runoff coefficient has been calculated using the nomogram presented on Figure 3 of Reference 1. In deriving the runoff coefficient a dominant vegetation type of cultivated land or short grass has been assumed and dominant soil type of clay/loam has been assumed. The slope is derived based on the catchment.
Climate change factor	40%	unitless	The recommended upper end increase in rainfall intensity to allow for climate change for 2085 to 2115 (reference 3) to test the sensitivity of the design and additional mitigation.

Storm Duration (hr)	Rainfall for the site derived from reference 2 (mm)	Rainfall Intensity corrected for climate change (mm/hr)	Volume of rainfall runoff in time period (m <sup>3</sup> )	Outflow in time period (m <sup>3</sup> )	Storage necessary in time period (m <sup>3</sup> )
0.25	29.69	166.26	908.01	5.93	902
0.5	38.79	108.61	1186.32	11.85	1174
0.75	44.39	82.86	1357.59	17.78	1340
1	48.39	67.75	1479.92	23.71	1456
1.5	54.55	50.91	1668.31	35.56	1633
2	59.39	41.57	1816.34	47.42	1769
3	67.22	31.37	2055.80	71.13	1985
4	73.3	25.66	2241.75	94.84	2147
5	78.18	21.89	2390.99	118.55	2272
6	82.2	19.18	2513.94	142.26	2372
7	85.57	17.11	2617.00	165.97	2451
8	88.42	15.47	2704.16	189.68	2514
9	90.88	14.14	2779.40	213.39	2566
10	93.02	13.02	2844.85	237.10	2608
15	100.66	9.39	3078.50	355.64	2723
16	101.76	8.90	3112.14	379.35	2733
17	102.77	8.46	3143.03	403.06	2740
18	103.69	8.06	3171.17	426.77	2744
18.25	103.9	7.97	3177.59	432.70	2745
18.5	104.11	7.88	3184.02	438.63	2745
18.75	104.31	7.79	3190.13	444.56	2746
19	104.52	7.70	3196.55	450.48	2746
19.25	104.71	7.62	3202.37	456.41	2746
19.5	104.9	7.53	3208.18	462.34	2746
19.75	105.09	7.45	3213.99	468.26	2746
20	105.28	7.37	3219.80	474.19	2746
20.5	105.63	7.21	3230.50	486.05	2744
21	105.98	7.07	3241.21	497.90	2743
22	106.63	6.79	3261.08	521.61	2739
23	107.23	6.53	3279.43	545.32	2734
24	107.8	6.29	3296.87	569.03	2728
25	108.31	6.07	3312.46	592.74	2720
30	110.48	5.16	3378.83	711.29	2668
35	112.15	4.49	3429.90	829.84	2600
40	113.5	3.97	3471.19	948.38	2523
50	115.52	3.23	3532.97	1185.48	2347
60	116.92	2.73	3575.79	1422.58	2153
70	118.12	2.36	3612.49	1659.67	1953
80	119.18	2.09	3644.90	1896.77	1748
90	120.15	1.87	3674.57	2133.86	1541
96	120.71	1.76	3691.70	2276.12	1416

<b>Maximum storage volume</b>	<b>2746</b> m <sup>3</sup>
<b>Critical Storm Period</b>	<b>19</b> hr

References

- Reference 1. National Coal Board, 1982. Technical Management of Water in the Coal Mining Industry.
- Reference 2. The Institute of Hydrology, 1999. Flood Estimation Handbook.
- Reference 3. <https://www.gov.uk/guidance/flood-and-coastal-risk-projects-schemes-and-strategies-climate-change-allowances#peak-rainfall-intensity-allowances>

Denotes parameters which are determined based on the restoration scheme, rainfall data or other constraints on discharge or water levels  
 Denotes parameters which are calculated based on other parameters

Table E14

Calculation of attenuation storage during a 1 in 30 year storm event plus an allowance for climate change for the attenuation basin C7 catchment using the Rational Method (reference 1)

Parameter	Value	Units	Reference
Catchment area	3	ha	Derived consistent with Section 5 and as shown on Figure 5.
Discharge rate	569	m <sup>3</sup> /day	QBAR (2l/s/ha)
Runoff coefficient	0.66	unitless	The runoff coefficient has been calculated using the nomogram presented on Figure 3 of Reference 1. In deriving the runoff coefficient a dominant vegetation type of cultivated land or short grass has been assumed and dominant soil type of clay/loam has been assumed. The slope is derived based on the catchment.
Climate change factor	20%	unitless	The recommended precautionary increase in rainfall intensity to allow for climate change for 2085 to 2115 (reference 3).

Storm Duration (hr)	Rainfall for the site derived from reference 2 (mm)	Rainfall Intensity corrected for climate change (mm/hr)	Volume of rainfall run off in time period (m <sup>3</sup> )	Outflow in time period (m <sup>3</sup> )	Storage necessary in time period (m <sup>3</sup> )
0.25	22.02	105.70	577.24	5.93	571
0.5	28.64	68.74	750.77	11.85	739
0.75	32.51	52.02	852.22	17.78	834
1	35.48	42.58	930.08	23.71	906
1.5	39.85	31.88	1044.63	35.56	1009
2	43.22	25.93	1132.98	47.42	1086
3	48.66	19.46	1275.58	71.13	1204
4	52.92	15.88	1387.25	94.84	1292
5	56.41	13.54	1478.74	118.55	1360
6	59.35	11.87	1555.81	142.26	1414
7	61.91	10.61	1622.92	165.97	1457
8	64.12	9.62	1680.85	189.68	1491
9	66.05	8.81	1731.45	213.39	1518
10	67.76	8.13	1776.27	237.10	1539
11	69.28	7.56	1816.12	260.81	1555
12	70.63	7.06	1851.51	284.52	1567
13	71.84	6.63	1883.22	308.22	1575
14	72.92	6.25	1911.54	331.93	1580
14.5	73.42	6.08	1924.64	343.79	1581
15	73.91	5.91	1937.49	355.64	1582
15.25	74.14	5.83	1943.52	361.57	1582
15.5	74.37	5.76	1949.55	367.50	1582
15.75	74.59	5.68	1955.31	373.43	1582
16	74.81	5.61	1961.08	379.35	1582
16.25	75.02	5.54	1966.59	385.28	1581
16.5	75.23	5.47	1972.09	391.21	1581
16.75	75.43	5.40	1977.33	397.14	1580
17	75.63	5.34	1982.58	403.06	1580
17.5	76.02	5.21	1992.80	414.92	1578
18	76.39	5.09	2002.50	426.77	1576
18.5	76.74	4.98	2011.67	438.63	1573
19	77.08	4.87	2020.59	450.48	1570
20	77.72	4.66	2037.36	474.19	1563
21	78.32	4.48	2053.09	497.90	1555
22	78.87	4.30	2067.51	521.61	1546
23	79.39	4.14	2081.14	545.32	1536
24	79.88	3.99	2093.99	569.03	1525
25	80.33	3.86	2105.78	592.74	1513
30	82.24	3.29	2155.85	711.29	1445
35	83.8	2.87	2196.75	829.84	1367
40	85.11	2.55	2231.09	948.38	1283
50	87.23	2.09	2286.66	1185.48	1101
60	88.87	1.78	2329.65	1422.58	907
70	90.33	1.55	2367.92	1659.67	708
80	91.69	1.38	2403.58	1896.77	507
90	92.98	1.24	2437.39	2133.86	304
96	93.73	1.17	2457.05	2276.12	181

<b>Maximum storage volume</b>	<b>1582</b> m <sup>3</sup>
<b>Critical Storm Period</b>	<b>15.5</b> hr

References

- Reference 1. National Coal Board, 1982. Technical Management of Water in the Coal Mining Industry.
- Reference 2. The Institute of Hydrology, 1999. Flood Estimation Handbook.
- Reference 3. <https://www.gov.uk/guidance/flood-and-coastal-risk-projects-schemes-and-strategies-climate-change-allowances#peak-rainfall-intensity-allowances>

Denotes parameters which are determined based on the restoration scheme, rainfall data or other constraints on discharge or water levels  
 Denotes parameters which are calculated based on other parameters



Table E15

Indicative height of the bunds needed round the proposed attenuation basins to accommodate additional storage needed for 1 in 100 year event with 40% allowance for climate change (CC)

Catchment	Storage volume for 1 in 30 year event with 20% CC (m <sup>3</sup> )	Storage volume for 1 in 100 year event with 40% CC (m <sup>3</sup> )	Area of basin designed to hold storage volume for 1 in 30 year event with 20% CC (m <sup>2</sup> )	Additional storage needed for 1 in 100 year event with 40% CC (m <sup>3</sup> )	Indicative height of bund needed to accommodate 1 in 100 year event with 40% CC (m)
Catchment 1 – Attenuation basin C1	8,465	14,975	8,900	6,510	0.7
Catchment 2 – Attenuation basin C2	2,902	5,040	3,525	2,138	0.6
Catchment 3 – Attenuation basin C3	3,806	6,619	2,780	2,813	1.0
Catchment 4 – Attenuation basin C4	1,315	2,284	1,575	969	0.6
Catchment 5 – Attenuation basin C5	2,702	4,703	3,310	2,001	0.6
Catchment 6 – Attenuation basin C6	1,801	3,142	1,215	1,341	1.1
Catchment 7 – Attenuation basin C7	1,582	2,746	2,225	1,164	0.5

**APPENDIX F**  
**DRAINAGE DITCH CALCULATIONS**

**Table F1. Calculations of the conveyancing capacity of the western drainage ditch northwards and southwards from the proposed discharge locations using the Manning Resistance Equation**

Western perimeter drainage ditch draining to west east crossing from catchments 3 & 4 & from off site	Parameter	Value	Unit	Justification
	Flow rate	63	l/s	Greenfield runoff from upstream catchment and catchments 3 & 4 (2l/s/ha)
	Flow rate for 100 year flood event plus climate change	316	l/s	The 1 in 100 year plus 40% allowance for climate change rainfall event for upstream catchment and catchments 3 & 4 (based on greenfield runoff rate above)
	Elevation of drain bed at upstream end	85.25	mAOD	The elevation of the current topography along western boundary at proposed C3 & C4 discharge locations - 0.75m (depth of ditch from surface water features survey in October 2019)
	Elevation of bed at downstream end	82.00	mAOD	The elevation of ground at the southern crossing - 0.75m (depth of ditch from surface water features survey in October 2019)
	Length of ditch	163	m	The length of the western perimeter ditch from the area of C3 & C4 discharges to the southern culvert
	Manning roughness coefficient	0.12305		Calculated based on Table F2.
	Bed width	1	m	Ditch dimension from surface water features survey in October 2019
	Depth of flow	0.30	m	The average depth of the channel.
	Channel area	0.3	m <sup>2</sup>	Calculated.
Wetted perimeter	1.60	m	Calculated.	
Hydraulic radius	0.19		Calculated.	
Gradient	0.0200		Calculated.	
Discharge	0.11	m <sup>3</sup> /s	Calculated using the Manning Resistance Equation as presented in Reference 1	
Discharge	112.89	l/s	Calculated.	
Depth of flow	0.70	m	The average depth of the channel.	
Channel area	0.7	m <sup>2</sup>	Calculated.	
Wetted perimeter	2.40	m	Calculated.	
Hydraulic radius	0.29		Calculated.	
Gradient	0.0200		Calculated.	
Discharge	0.35	m <sup>3</sup> /s	Calculated using the Manning Resistance Equation as presented in Reference 1	
Discharge	354	l/s	Calculated.	

Western perimeter drainage ditch draining to southern ditch from catchment 5 & from off site	Parameter	Value	Unit	Justification
	Flow rate	13	l/s	Greenfield runoff from upstream catchment and catchment 5 (2l/s/ha)
	Flow rate for 100 year flood event plus climate change	67	l/s	The 1 in 100 year plus 40% allowance for climate change rainfall event for upstream catchment and catchment 5 (based on greenfield runoff rate above)
	Elevation of drain bed at upstream end	88.39	mAOD	The elevation of the current topography along western boundary at proposed C5 discharge location - 0.75m (depth of ditch from surface water features survey in October 2019)
	Elevation of bed at downstream end	87.35	mAOD	The elevation of ground at the southern track - 0.75m (depth of ditch from surface water features survey in October 2019)
	Length of ditch	63	m	The length of the western perimeter ditch from the area of C5 discharge to the southern track
	Manning roughness coefficient	0.107		Calculated based on Table F2.
	Bed width	0.6	m	Ditch dimension from surface water features survey in October 2019
	Depth of flow	0.20	m	The average depth of the channel.
	Channel area	0.12	m <sup>2</sup>	Calculated.
Wetted perimeter	1.00	m	Calculated.	
Hydraulic radius	0.12		Calculated.	
Gradient	0.0166		Calculated.	
Discharge	0.04	m <sup>3</sup> /s	Calculated using the Manning Resistance Equation as presented in Reference 1	
Discharge	35.17	l/s	Calculated.	
Depth of flow	0.40	m	The average depth of the channel.	
Channel area	0.24	m <sup>2</sup>	Calculated.	
Wetted perimeter	1.40	m	Calculated.	
Hydraulic radius	0.17		Calculated.	
Gradient	0.0166		Calculated.	
Discharge	0.09	m <sup>3</sup> /s	Calculated using the Manning Resistance Equation as presented in Reference 1	
Discharge	89.24	l/s	Calculated.	

**References**

Reference 1. Highways Agency. February 2004. Drainage of runoff from natural catchments. Design manual for roads and bridges, Volume 4, Section 2, Part 1. Report reference HA 106/04

Denotes parameters which are determined based on the restoration scheme, rainfall data or other constraints on discharge or water levels

Denotes parameters which are calculated based on other parameters

Denotes parameters which are specified to achieve the necessary flow in the ditch

Table F2. Calculation of Manning's Roughness Coefficient, n

$$n = (n_b + n_1 + n_2 + n_3 + n_4)m$$

Western ditch draining to north			
Parameter	Symbol	Value	Justification
Base value	$n_b$	0.032	Upper end of values for straight uniform channel in Firm Soil (ie clay material).
Irregularity of the channel	$n_1$	0.005	Upper end of minor irregularities.
Cross section	$n_2$	0.005	Size and shape of channel does not change significantly. This is the upper end of the alternating occasionally category.
Obstructions	$n_3$	0.015	Upper end of minor obstructions category.
Vegetation	$n_4$	0.05	Upper end of large category.
Meandering	$m$	1.15	Appreciable meandering - a bend in the ditch course (~35degrees) & will be followed by a further bend (~20 degrees)
	$n$	0.12305	

Western ditch draining to south			
Parameter	Symbol	Value	Justification
Base value	$n_b$	0.032	Upper end of values for straight uniform channel in Firm Soil (ie clay material).
Irregularity of the channel	$n_1$	0.005	Upper end of minor irregularities.
Cross section	$n_2$	0.005	Size and shape of channel does not change significantly. This is the upper end of the alternating occasionally category.
Obstructions	$n_3$	0.015	Upper end of minor obstructions category.
Vegetation	$n_4$	0.05	Upper end of large category.
Meandering	$m$	1	No significant meandering
	$n$	0.107	

**References**

Reference 1. United States Geological Survey. 1989. Guide for Selecting Manning's Roughness Coefficients for Natural Catchments and Floodplains. United States Geological Survey Water-Supply Paper

**APPENDIX DEC G**  
**TREE MANAGEMENT SCHEME**  
**ANNEX DEC G1 TREE PROTECTION PLAN**

## Appendix DEC G

### Tree management scheme

- G1. The Root Protection Areas (RPA) for the trees that adjoin the proposed western extension but which are outside the DCO application boundary have been assessed and are reported in the Arboricultural Impact Assessment which is presented in the Ecological Impact Assessment at Appendix ES13.1 to the Environmental Statement (PINS document reference 5.4.13.1). No excavation works will be undertaken in the identified RPA. The identified RPA are included in the boundary standoff areas created to include the RPA and ecological protection areas. The identified RPA is the minimum standoff distance however for most of the site boundaries, the width of the ecological protection area is greater than that needed for the RPA for the adjacent trees. The standoff distances and their derivation are set out in the Boundary design principles for the proposed western extension (Appendix DEC B).
- G2. The trees within and adjacent to the proposed western extension are shown on Figure 1-02 (ESL drawing number 118-L049-001, Annex DEC G1 Tree Protection Plan). The trees that are located in the application boundary are Trees T01-C3, T02-C3, DW01 (dead), Tree Group TG03-B3, Tree T03-A3, and Tree T04-A3. As a result of the proposed development tree T04-A3 will be removed. Tree T04-A3 is a mature oak at the eastern end of hedgerow H02-A3. Tree Group TG03-B3 located to the west of the swallow hole may be removed in order to facilitate adequate access to the area for the further site investigation. Tree Group TG03-B3 comprises a mix including T03-A3, a mature oak in fair condition, and hawthorn, blackthorn and elder scrub with occasional willow. In the Arboricultural Impact Assessment it is concluded that the loss of tree T04-A3 and tree group TG03-B3 including tree T03-A3 will have a minor impact on the site's amenity value and that the loss will be more than mitigated by the proposed restoration scheme. Regardless of this conclusion it is proposed that during the design and agreement of the details of the site investigation with the Environment

Agency in the area of TG03-B3 priority will be given to retaining as much as possible of the vegetation in this location without compromising the needs of the site investigation. The proposals for the management of this area are set out in the Ecological Management, Monitoring and Aftercare Plan (Appendix DEC E).

- G3. Trees T01-C3, T02-C3 and DW01 (Annex DEC G1) are located on the western boundary of the northern field of the proposed western extension. Trees T01-C3 and T02-C3 are ash trees in poor condition and DW01 is standing deadwood. In the Arboricultural Assessment the loss of these trees has been assessed and is considered acceptable due to the significant woodland planting which will be implemented as part of the restoration proposals. Notwithstanding this assessment these trees will be retained as the development proposals progress and monitored as part of the ongoing ecological monitoring. Where possible the trees will be retained as live trees or as standing deadwood provided there are no health and safety concerns. If the trees are regarded as unsafe they will be felled.

**KEY**

- Cat A tree
- Cat C tree
- Target note
- Proposed Western Extension boundary
- Cat A hedgerow
- Cat B hedgerow
- Protective fencing
- Cat A tree group
- Cat B tree group
- RPA/CEZ
- Ancient Woodland
- National Nature Reserve
- Site of Special Scientific Interest

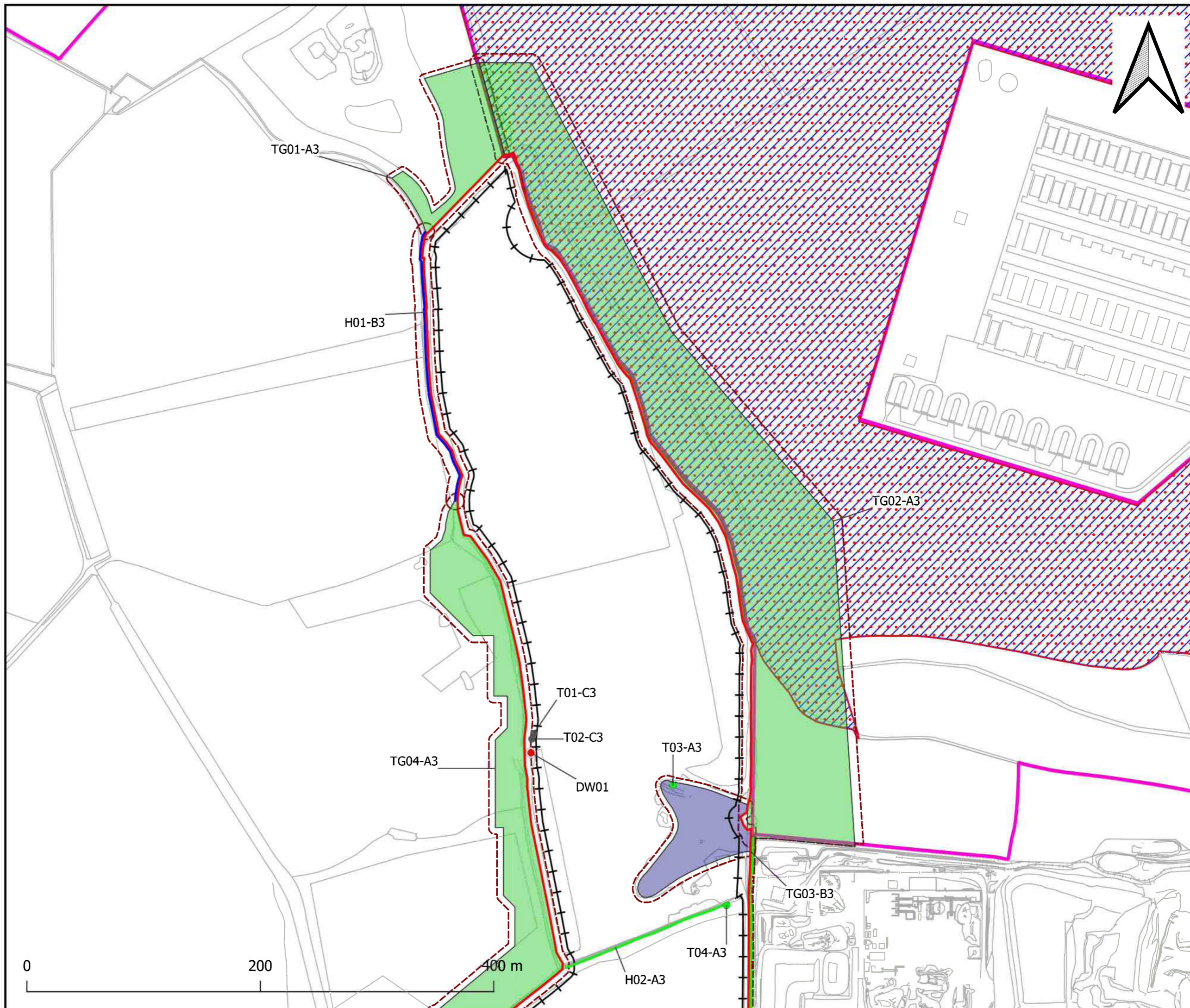

SITE NAME:  
**ENRMF proposed Western Extension.**

DRAWING TITLE:  
**Tree protection plan.**

Dwg no.: 118-L049-001      Date: Jul 2021  
Scale: 1:3,000 @ A3      Figure: 1-01

This product includes mapping data licensed from Ordnance Survey ©. © Crown copyright and/or database rights 2020. License number 100012108. The original of this drawing was produced in colour - a monochrome copy should not be relied upon.



**KEY**

- Cat A tree
- Proposed Western Extension boundary
- Cat A hedgerow
- Protective fencing
- Cat A tree group
- Cat B tree group
- RPA/CEZ
- Ancient Woodland

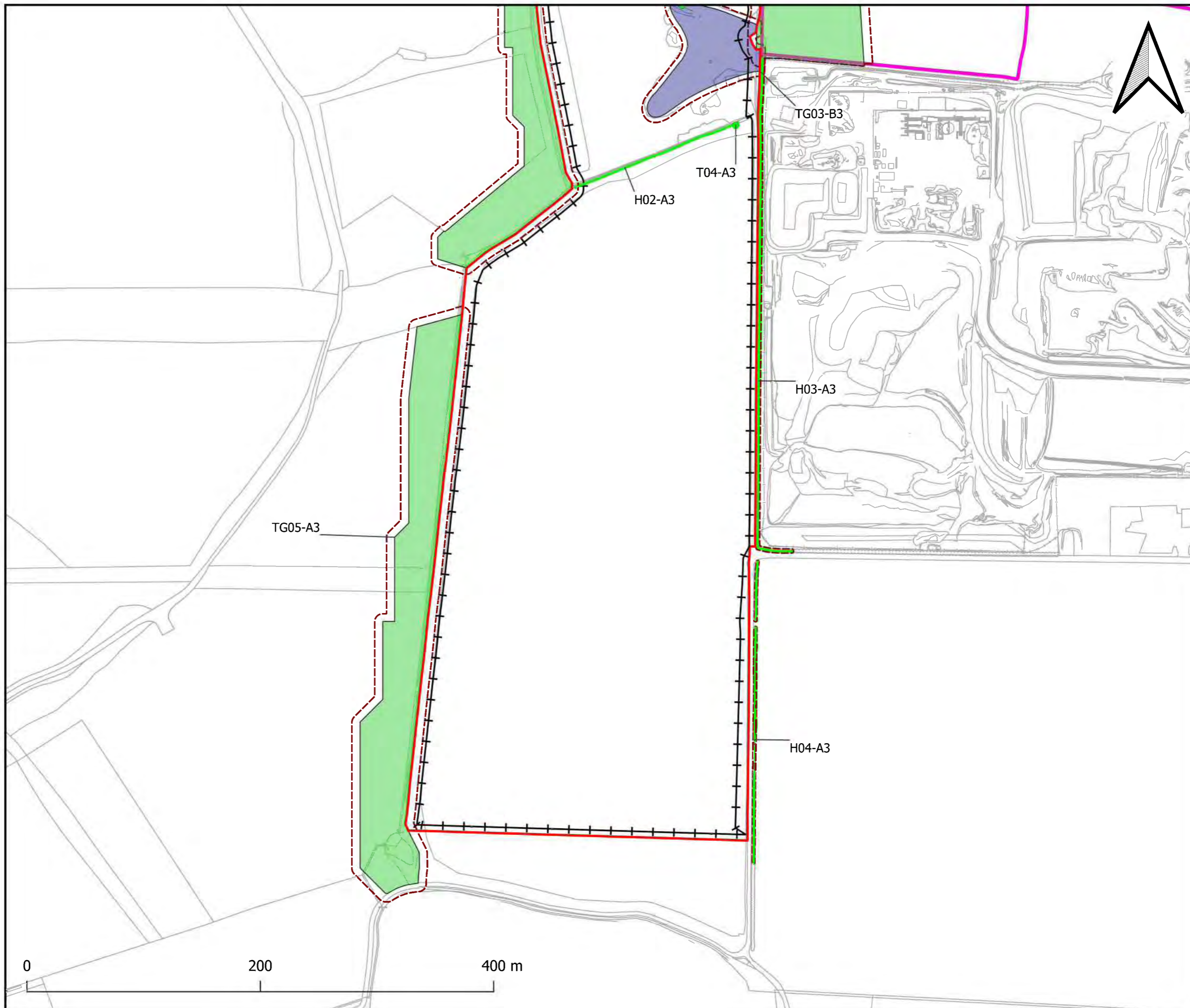

SITE NAME:  
**ENRMF proposed Western Extension.**

DRAWING TITLE:  
**Tree protection plan.**

Dwg no.: 118-L049-001      Date: Jul 2021  
Scale: 1:3,000 @ A3      Figure: 1-02

This product includes mapping data licensed from Ordnance Survey ©. © Crown copyright and/or database rights 2020. License number 100012108. The original of this drawing was produced in colour - a monochrome copy should not be relied upon.

**APPENDIX DEC H**  
**DUST MANAGEMENT SCHEME**  
**TABLE DEC H1 DUST CONTROL MEASURES**

## Appendix DEC H

### Dust Control Measures

- H1. The dust emissions at the site will continue to be controlled effectively using existing tried and tested methods to a standard such that it is unlikely that there will be significant dust emissions from the site.
- H2. Emissions of dust associated with the landfill and waste treatment activities are controlled through procedures in place and regulated by the Environment Agency through the Environmental Permit. Boundary monitoring for PM<sub>10</sub> particulates, asbestos fibres and deposited dust is carried out and reported to the Environment Agency. Threshold limits are set for the parameters that are monitored.
- H3. The potential for dust generation as a result of general site activities including material extraction and stockpiling as well as soil stripping also will be controlled. As explained in Section 22 of the Environmental Statement dust generation from these activities can be controlled effectively and the effectiveness of the dust control measures are dependent on good site management.
- H4. The control measures that will continue to be implemented at the site are presented in Table DEC H1 below:

Table DEC H1

## Dust control measures

Activity	Controls
Extraction, movement and stockpiling of clay and overburden	Current controls will continue to be used for future extraction and handling of clay. A water bowser will be used to dampen down the clay and internal hauls roads if the generation of dust is likely or has been observed during extraction and/or handling operations.
Landfill engineering works	During landfill engineering works clay is in a damp condition to ensure that the optimum moisture content is maintained therefore the potential for dust generation is low.
Waste treatment	Processes at the treatment plant will be wet processes or will incorporate damping systems as an inherent part of the treatment processes.
Movement of HGVs, plant and machinery	<p>Mobile plant will be regularly serviced.</p> <p>The site haul road is hard-surfaced to the wheelwash area on the southern boundary of and close to the south eastern corner of the site to reduce the mud and debris which may be carried by vehicles onto the local road network.</p> <p>Other site haul roads are formed of compacted hardcore or similar material.</p> <p>The movement of mobile plant and site traffic is restricted to defined haul routes.</p> <p>Haul roads will be sprayed as necessary.</p> <p>The hard-surfaced areas of the haul routes will be checked daily and cleaned as necessary.</p> <p>The running surface of unsurfaced roads will be maintained to prevent the formation of ruts and potholes.</p> <p>All vehicles leaving the site following delivery of waste or the collection of clay are inspected visually by site operatives before leaving the site and are obliged to use the wheel wash.</p> <p>The hard surfaced site road and Stamford Road are swept regularly to clear mud or debris.</p> <p>Vehicle exhausts will point above the horizontal. Vehicle speed limits of 15mph will be enforced to minimise the potential for dust generation during vehicle movements.</p> <p>Careful loading to minimise spillage and drop heights.</p>
Soil stripping and placement during restoration	<p>Soils must be handled when dry and friable therefore only limited use can be made of water sprays to dampen the material.</p> <p>Drop heights for tipping will be minimised.</p> <p>Movement of materials within the site will cease during high winds if it could generate dust emissions beyond the site boundary.</p> <p>Stockpiles which will be in place for a long period will be seeded where necessary to minimise wind blow as soon as conditions permit following formation.</p>

Activity	Controls
	Restored areas will be planted with vegetation as soon as possible after soil placement.

**APPENDIX DEC I**

**SOIL HANDLING AND MANAGEMENT SCHEME  
ANNEX DEC I1 MAFF GOOD PRACTICE GUIDE FOR HANDLING SOIL SHEETS  
1-4  
ANNEX DEC I2 BIRD HAZARD MANAGEMENT SCHEME**

## Appendix DEC I

### Soil Handling and Management Scheme

- I1. This scheme relates to the handling, management and storage of soils. The management of stockpiles of clay and overburden and the locations for all stockpiles is addressed under the Stockpile Management Scheme (Appendix DEC J).

#### Ground preparation

- I2. Reference will be made to the Ecological Management, Monitoring and Aftercare Plan (Appendix DEC E) and to the Archaeology Mitigation Strategy (Appendix DEC A) to identify any preliminary works that need to be completed prior to the commencement of soil stripping. Soil stripping will not commence until the necessary works have been completed in the relevant areas.
- I3. Prior to stripping the topsoil all above-ground vegetation will be cut short or the arable crops will have been harvested so that the amount of vegetation within the topsoil strip is minimised.
- I4. For each phase of soil stripping, the haul routes and footprints of the soil storage areas (see below) will be prepared in advance of the soil stripping operations. The soil storage areas will be prepared so that like is stored on like i.e. topsoil on topsoil. The soil will be stored in stockpiles in the areas of Phases 19-21 as described in the Stockpile Management Scheme (Appendix DEC J). The haul routes will be prepared so that the dump trucks travel only on overburden (clay).

#### Soil stripping

- I5. All soil shall only be stripped and moved when in a dry and friable condition. For all soil types, no soil handling will proceed during or shortly after significant rainfall, and/or when there are any puddles on the soil surface.

16. All soil and soil forming materials shall be handled in accordance with MAFF's Good Practice Guide for Handling Soil Sheets 1-4 (handling soils using backacter excavators and dump trucks) (Annex DEC I1).
17. Topsoil and upper subsoil will each be stripped to a depth of 25cm across the proposed western extension. These soils will be stored separately in the stockpile area prior to use in restoration.
18. During topsoil stripping the bird hazard management plan will be implemented (Annex DEC I2)

### **Soil storage**

19. Where stripped soils are not placed directly in restoration works on previously completed phases, the soils will be temporarily stored in the stockpile area and used in the restoration of the first available phase or restoration. The topsoil and subsoil from the area of Grade 3a agricultural land (Figure DEC J1) will be stored separately to soils from other areas and used in the restoration of the areas to be developed as calcareous grassland.
110. Bunds for the storage of soils shall conform to the following criteria:
  - (i) Topsoil and subsoil shall be stored separately.
  - (ii) Where continuous bunds are used, dissimilar soils shall be separated by a third material, such as excavated overburden.,
  - (iii) topsoil bunds shall not exceed 3m in height and subsoil bunds shall not exceed 5m in height.
  - (iv) Materials shall be stored like upon like, so that topsoil shall be stripped from beneath subsoil bunds, and subsoil from beneath overburden bunds.
  - (v) All storage bunds containing soils which are intended to remain in situ for more than 6 months or over the winter period will be grassed over and weed control and other necessary maintenance will be carried out.
  - (vi) All topsoil and subsoil shall be retained on the site and used in the restoration of the site.



## Soil replacement

- I11. The soil will remain in bunds until needed for use in restoration. Prior to reuse and placement, soil testing will be carried out and a protocol will be prepared for soil mixing and adaption where needed based on the type of habitat which is to be developed in the area of restoration to which the soil will be directed. The details of the soil mixing and nutrient requirements will be specified in the Phasing, Landscaping and Restoration Scheme which will be prepared and submitted for approval in accordance with Requirement 4 of the draft DCO (PINS document reference 3.1).
- I12. Between 1m and 1.5m of restoration materials will be used. The restoration materials will generally comprise, 25cm subsoil and 25cm topsoil with at least 50cm overburden. The Grade 3a soils will be used in the creation of the calcareous grassland. Additional soil forming materials may be imported for use in restoration if soils with a specific nutrient content are necessary. Notwithstanding these general guidelines, the details of the soil depths and types will be specified for each area of restoration in the Phasing, Landscaping and Restoration Scheme which will be prepared and submitted for approval in accordance with Requirement 4 of the draft DCO (PINS document reference 3.1). The soil will be replaced in accordance with MAFF Guidance Soil Sheet 4 (Annex DEC I1).



# **GOOD PRACTICE GUIDE FOR HANDLING SOILS**

## **Sheet 1:**

### **Soil Stripping with Excavators and Dump Trucks**

**Issued by the Farming and Rural Conservation Agency, Cambridge**

**April 2000**

## **MAFF FOREWORD**

Standards of restoration of minerals and waste sites have steadily improved in recent years, with operators increasingly aware of their environmental responsibilities. The industry is putting forward more imaginative restoration concepts to a variety of afteruses, and is more aware than ever that it will be judged on the standard of that restoration, and the sustainability of the development.

Sustainable mineral development means balancing economic, environmental and social needs, whilst using resources wisely. The UK Strategy for Sustainable Development recognises the importance of safeguarding agricultural land to meet the needs of future generations, and minimising the loss of soils to new development\*.

Improved restoration standards have sometimes enabled planning permission to be given for best and most versatile agricultural land to be worked for minerals, on the basis that it can be restored in a way that safeguards its long-term agricultural potential\*\*. Inherent in these high standards of restoration is the requirement to handle soils in such a way that damage to their structure is minimised. It is the aim of this Guide to provide comprehensive advice on soil handling “Good Practice” to operators, soil moving contractors, consultants and planning authorities.

The Guide is in the form of 15 Sheets giving advice on soil stripping, the forming and taking down of soil storage mounds, and soil replacement operations using excavators, earth scrapers or bulldozers. There are also four Guidance Sheets on remedial works involving the removal of stones and damaging materials, and decompaction during the replacement operations.

This document should be cited as MAFF (2000), Good Practice Guide for Handling Soils (version 04/00). FRCA, Cambridge.

**Any views expressed in the guidance are those of the consultant and do not necessarily represent the view of the Ministry of Agriculture, Fisheries and Food.**

\*(DETR, A Better Quality of Life, May 1999, paragraphs 6.66 and 8.50)

\*\*MPG7 (November 1996, paragraph 3).

### **Acknowledgements**

The Guide was written and prepared by Dr R N Humphries of Humphries Rowell Associates, Charnwood House, Loughborough, LE11 3NP, UK. The art work was by R Shenton of H J Banks & Co.

## **SHEET 1 SOIL STRIPPING WITH EXCAVATORS & DUMP TRUCKS**

The purpose of this Guidance Sheet is to provide a model method for best practice where excavators and dump trucks are to be used to strip soil. This Guidance Sheet comprises 6 pages of text, 3 figures and a user response form.

The model method may need to be modified according to site conditions or requirements of the Planning Authority. Where this is the case, deviation from the model should be recorded with reasons. The guidance does not specify the type, size or model of equipment, but this should have been agreed as part of the planning conditions or as a reserved matter. The machines should be of a kind which will cause the minimum compaction whilst being operationally efficient (eg wide tracked), and must be well maintained at all times.

Persons involved in the handling of soils, overburden etc., and in the construction or removal of mounds or tips, must comply with the Health and Safety at Work Etc. Act 1974 and its relevant statutory provisions, and in particular those aspects which relate to the construction and removal of tips, mounds and similar structures. This requirement takes preference over any suggested practice in the Sheets.

The user of these guidelines is solely responsible for all liabilities that might arise. No liabilities are accepted for any losses of any kind arising from the use of this guidance.

This soil handling method uses back-acting excavators in combination with dump trucks (articulated or rigid bodied). An excavator is used to strip soil and load it into dump trucks for transportation to replacement areas or to storage.

The soil handling method can affect the agricultural quality of the restoration through severe soil deformation (compression and smearing). This is primarily caused through trafficking, the effects of which increases with increasing soil wetness.

The advantage of this model method, if correctly carried out, is that it should avoid severe deformation of the soil as trafficking is minimised. Consequently, there should be no need for decompaction treatment during the operation.

The key operational points to ensure avoidance of severe soil deformation are as follows:

- (i) To minimise compaction:
  - the dump trucks must only operate on the 'basal'/non-soil layer, and their wheels must not on any circumstances run on to the soil layer(s).
  - the excavator should only operate on the topsoil layer.
  - the adoption of a bed/strip system avoids the need for the trucks to travel on the soil layers.
  - the machines are to only work when ground conditions enable their maximum operating efficiency.
  - if compaction is caused then measures are required to treat it (see Sheets 18 & 19).
- (ii) To minimise soil wetness and re-wetting:
  - the soil layers should have a moisture content below their lower plastic limit\*. Moisture content should be assessed by oven drying\* of samples taken from representative locations and mid/lower points of each soil horizon. [\*Or as required in the planning conditions.]
  - the bed/strip system provides a basis to regulate the exposure of lower soil layers to periods of rain and a means of maintaining soil moisture contents. The soil profile within the active strip should be stripped to the basal layer before rainfall occurs and before stripping is suspended.

- measures are required to protect the face of the soil layer from ponding of water and maintain the basal layer in a condition capable of supporting dump trucks.
- the area to be stripped is to be protected from in-flow of water, ponding etc. Wet sites should be drained in advance.
- the maintenance of a transpiring crop is important, and an appropriate cropping regime should be established for the year of soil stripping. Before stripping, excess vegetation should be removed; in the case of grassland it should be cut or grazed short and arable crops should have been harvested.

#### The Stripping Operation:

- 1.1 The area to be stripped is to be protected from in-flow of water, ponding etc. Wet sites should be drained in advance.
- 1.2 Soil stripping operations should not start until the required soil moisture levels are reached (as determined by the agreed method), and should be suspended as soon as the water content returns to these levels. Prior to work commencing a Meteorological Office forecast should be obtained which gives reasonable confidence of soil stripping proceeding without interruptions from rainfall events. If significant rainfall occurs during operations, the stripping must be suspended, and where the soil profile has been disturbed it should be removed to base level. Stripping must not restart unless the weather forecast is expected to be dry for at least a full day.

- 1.3 All machines must be in a safe and efficient working condition at all times.  
The machines are to only work when ground conditions enable their maximum operating efficiency. The operation is to be suspended before traction becomes a problem or the integrity of the basal layer and haul routes fail.
- 1.4 The operation should follow a detailed stripping plan showing soil units to be stripped, haul routes and the phasing of vehicle movements. The soil units should be defined on the site with information to distinguish types and layers, and ranges of thickness. Detailed daily records should be kept of operations undertaken, and site and soil conditions.
- 1.5 Within each soil unit the soil layers above the base/formation layer are to be stripped in sequential strips with the topsoil layer stripped first, followed by the subsoil layers; each layer stripped to its natural thickness without incorporating material from the lower layers. The next strip is not started until the current strip is completely stripped to the basal layer. This is often referred to as the 'bed or strip system'. The system involves the progressive stripping of the soil in strips (Figure 1.1). Where there is a gradient to the site, the main axis of the soil strips should be along the main axis of the slope.
- 1.6 The haul routes and soil storage areas must be defined, and should be stripped first in a similar manner.
- 1.7 The excavator is only to work on the topsoil layer; the dump trucks are only to travel on the basal/formation layer.
- 1.8 Stripping is to be undertaken by the excavator standing on the surface of the topsoil and digging the topsoil to its maximum depth, and it loading into dump trucks. Generally a bucket with teeth is preferable to one without. The dump trucks draw alongside the exposed soil profile, standing and travelling only on the basal layer (Figure 1.2).

- 1.9 The initial strip width and axis should be demarcated. Strip width is determined by the length of the excavator boom less the stand-off to operate; typically about 3-4m. Effective boom length can also reduce with profile depths greater than 1m; at 1.5m effective reach of standard boom may result in 2m wide strips.
- 1.10 Topsoil should be recovered to the full width of the strip without contamination with subsoil (not more than 20% of the lower horizon should be exposed at the layer junction within the strip). The thickness and identification of the horizon junction must be verified before and during stripping. The full thickness of the topsoil horizon should be stripped progressively along the strip before subsoil horizons are started (Figure 1.2).
- 1.11 The upper subsoil in the current strip is to be stripped and monitored in the same manner. The final 25cm of the subsoil layer should be left as a step to protect the adjacent topsoil layer from local collapses. The process is to be repeated for the lower subsoil and any other lower layer to be recovered as a soil material (Figure 1.3).
- 1.12 On completion of the strip, the procedures are repeated sequentially for each subsequent strip until the area is completely stripped.
- 1.13 Where the soils are to be directly replaced without storage in mounds, the initial strip of the upper horizons will have to be stored temporarily to release the lowest layer and enable the sequential movement of materials. The stored initial soil material would normally be placed on the lower layer removed from the final strip at the end of the programme or on partially completed profiles if rain interrupted the operation.



- 1.14 Where the stripping operation is likely to be interrupted by rain or there is likely to be over-night rain remove any exposed subsoil down to the basal layer before suspending operations. Make provisions to protect base of current or next strip from ponding/runoff by sumps and grips, and also clean and level the basal layer. At the start of each day ensure there is no ponding in the current strip or operating areas, and the basal layer is to level with no ruts.

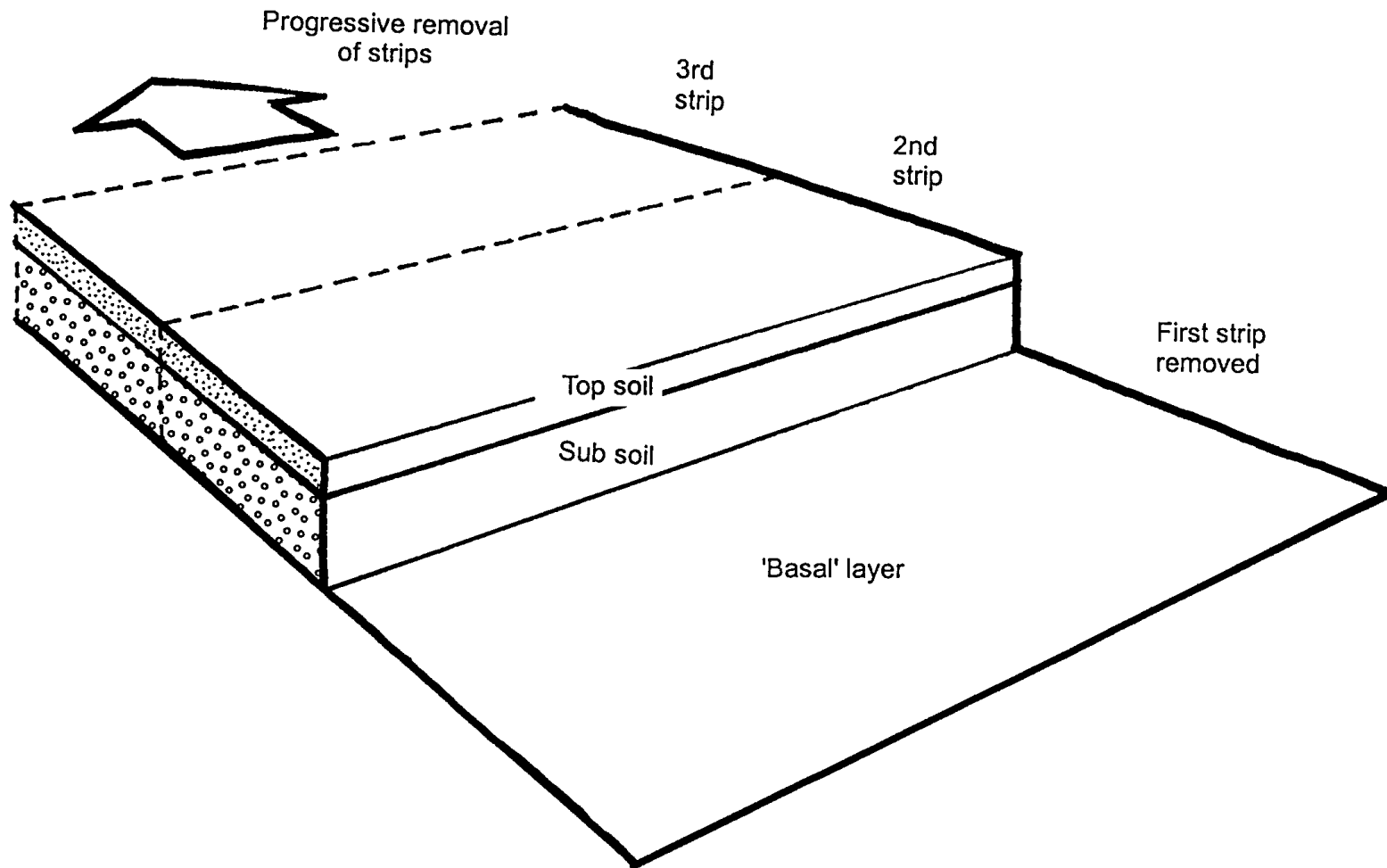

**Figure 1.1 Soil stripping with excavators and dump trucks:  
The bed system**

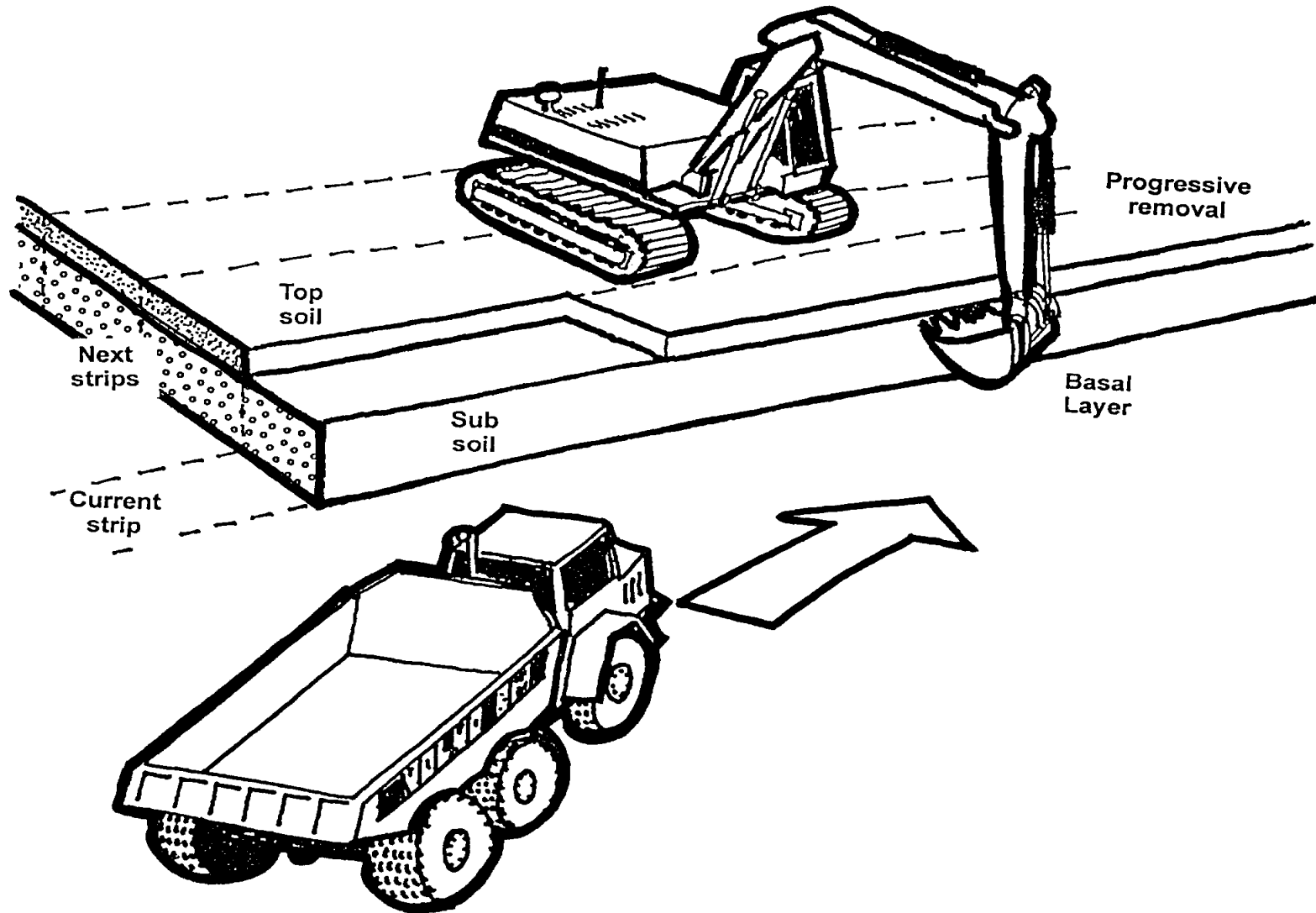

**Figure 1.2 Stripping with excavators and dump trucks:  
Removal of top soil from a strip**

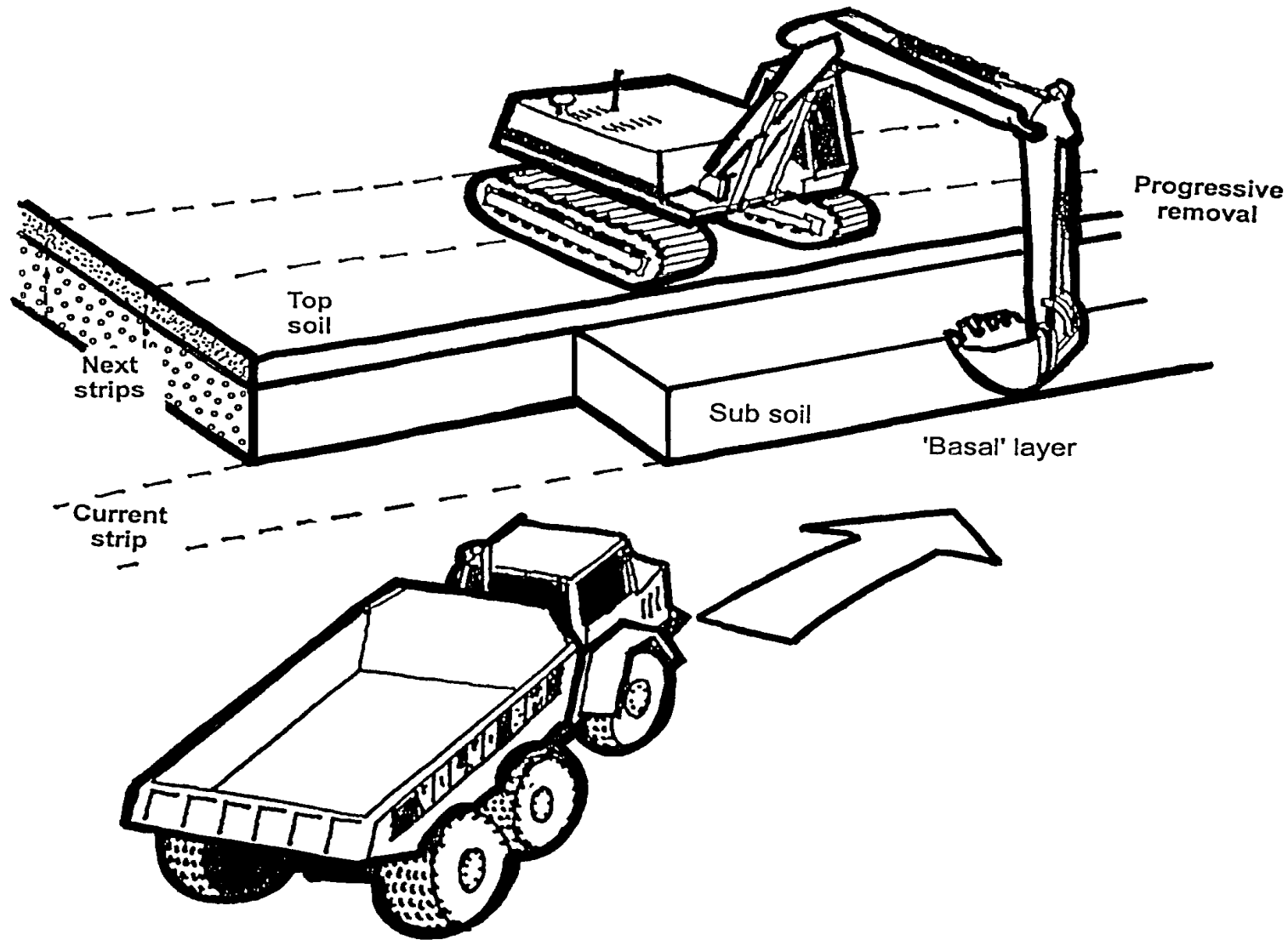

**Figure 1.3 Stripping with excavators and dump trucks:  
Removal of sub soil from a strip**

**SHEET 1**

**Version: 04/00**

**FEEDBACK**

**It would be most helpful in assessing access to this Guidance, the use made of it and its further development if the following could be completed and returned to the FRCA:**

<b><u>Organisation</u></b>			
<b><u>Contact Name</u></b>			
<b><u>Telephone/e-mail</u></b>		<b><u>Date</u></b>	

**Is the Guidance to be used generally or for specific site/works?**

**General**  **Specific site**

**If specific site – please identify**

**Name**  **County**  **Country**

**How was the Guidance obtained?**

**Internet**  **FRCA**  **Other**

**If other – please identify source**

**Source of Guidance**

**When was the Guidance obtained?**

**Month**  **Year**

**Please provide any helpful comment/experience which may benefit the Guidance** (use additional sheets if necessary)

**Please copy and return to: M Stephen, Farming and Rural Conservation Agency, Rural Development Team, Government Buildings, Block C, Brooklands Avenue, Cambridge CB2 2BL, UK**



# **GOOD PRACTICE GUIDE FOR HANDLING SOILS**

## **Sheet 2:**

### **Building Soil Storage Mounds with Excavators and Dump Trucks**

**Issued by the Farming and Rural Conservation Agency, Cambridge**

**April 2000**

## **MAFF FOREWORD**

Standards of restoration of minerals and waste sites have steadily improved in recent years, with operators increasingly aware of their environmental responsibilities. The industry is putting forward more imaginative restoration concepts to a variety of afteruses, and is more aware than ever that it will be judged on the standard of that restoration, and the sustainability of the development.

Sustainable mineral development means balancing economic, environmental and social needs, whilst using resources wisely. The UK Strategy for Sustainable Development recognises the importance of safeguarding agricultural land to meet the needs of future generations, and minimising the loss of soils to new development\*.

Improved restoration standards have sometimes enabled planning permission to be given for best and most versatile agricultural land to be worked for minerals, on the basis that it can be restored in a way that safeguards its long-term agricultural potential\*\*. Inherent in these high standards of restoration is the requirement to handle soils in such a way that damage to their structure is minimised. It is the aim of this Guide to provide comprehensive advice on soil handling “Good Practice” to operators, soil moving contractors, consultants and planning authorities.

The Guide is in the form of 15 Sheets giving advice on soil stripping, the forming and taking down of soil storage mounds, and soil replacement operations using excavators, earth scrapers or bulldozers. There are also four Guidance Sheets on remedial works involving the removal of stones and damaging materials, and decompaction during the replacement operations.

This document should be cited as MAFF (2000), Good Practice Guide for Handling Soils (version 04/00). FRCA, Cambridge.

**Any views expressed in the guidance are those of the consultants and do not necessarily represent the view of the Ministry of Agriculture, Fisheries and Food.**

\*(DETR, A Better Quality of Life, May 1999, paragraphs 6.66 and 8.50)

\*\*MPG7 (November 1996, paragraph 3).

### **Acknowledgements**

The Guide was written and prepared by Dr R N Humphries of Humphries Rowell Associates, Charnwood House, Loughborough, LE11 3NP, UK. The art work was by R Shenton of H J Banks & Co.

**April 2000**

## **SHEET 2 BUILDING SOIL STORAGE MOUNDS WITH EXCAVATORS & DUMP TRUCKS**

The purpose of this Guidance Sheet is to provide a model method for best practice where excavators and dump trucks are to be used to build soil storage mounds. This Guidance Sheet comprises 5 pages of text, 2 figures and a user response form.

The model may need to be modified according to site conditions or requirements of the Planning Authority. Where this is the case, deviation from the model should be recorded with reasons. The guidance does not specify the type, size or model of equipment, but this should have been agreed as part of the planning conditions or as a reserved matter. The machines should be of a kind which will cause the minimum compaction whilst being operationally efficient (eg wide tracked), and must be well maintained at all times.

Persons involved in the handling of soils, overburden etc., and in the construction or removal of mounds or tips, must comply with the Health and Safety at Work Etc. Act 1974 and its relevant statutory provisions, and in particular those aspects which relate to the construction and removal of tips, mounds and similar structures. This requirement takes preference over any suggested practice in the Sheets.

The user of these guidelines is solely responsible for all liabilities that might arise. No liabilities are accepted for any losses of any kind arising from the use of this guidance.

This soil handling method uses back-acting excavators to build the storage mound in combination with dump trucks (articulated or rigid bodied) to transport the soil.

The soil handling method can affect the agricultural quality of the restoration through severe soil deformation (compression and smearing). This is primarily caused through trafficking, the effects of which increases with increasing soil wetness.



The advantage of this model method, if correctly carried out, is that it should minimise severe deformation of the soil as trafficking is minimised. However, compaction due to trafficking will be unavoidable in mounds where the height of the mound exceeds the effective reach of the excavator boom and the trucks have to travel on mounded soil. Such compaction will need treatment during the excavation operation (see Sheets 3 and 18).

The key operational points to minimise the degree and extent of severe soil compaction (and for the effective treatment of compaction) are as follows:

- (i) To minimise compaction:
  - strip in advance the soil to basal layer along haul routes and the operational footprint of the storage mound.
  - dump trucks are only to stand and travel on the basal layer (unless raising the next level in multi-tier mounds).
  - the machines are to only work when ground or soil surface conditions enable their maximum operating efficiency.
  - single-tier mounds are preferred to multi-tier mounds as it avoids the need for trafficking on the soil being stored.
  - raise the soil using only the excavator and maximise the mound height before trucks allowed to access upper surface.
  - in the raising of multi-tier mounds, trafficking is to be confined to the upper surface of the lower tier. [This layer will require decompaction on excavation of the mound. Sheets 3 & 18]
- (ii) To minimise the wetting of soils:
  - site soil mounds in dry locations and protect from run-off from adjacent areas. Drain if a wet location.

- raise the soil mound to maximum height progressively along the axis of the mound, and shape the mound as it is being built to shed water and whenever stripping is suspended.
- measures are required to protect the face of the soil layer from ponding of water and maintain the basal layer in a condition capable of supporting dump trucks.

### The Storage Operation

- 2.1 The mounds should be sited on dry ground, not in hollows and should not disrupt local surface drainage. Where necessary mounds should be protected from run-off/ponding by a cut-off ditch which is linked to appropriate water discharge facilities. Where the storage mound is in a hollow due to the removal of surface soils, measures should be undertaken to ensure that water is not able to pond within the storage area.
- 2.2 All machines must be in a safe and efficient working condition at all times. The machines are to only work when ground conditions enable their maximum operating efficiency. The operation is to be suspended before traction becomes a problem or the integrity of the basal layer and haul routes fails; haul routes must be maintained.
- 2.3 The operation should follow a detailed soil stripping/storage plan showing soil units to be stripped and stored, haul routes and the phasing of vehicle movements. The soil units should be defined within the site with information to distinguish types and layers, with information about ranges of thickness. Detailed daily records should be kept of operations undertaken, and site and soil conditions.

- 2.4 Remove topsoil and subsoil to basal layer from the haul routes, footprint of the storage mound and any other operating area in advance; adopting the practices outlined in Sheet 1. These soils should be stored in their respective mounds.
- 2.5 The dump trucks must only travel within the haul route and operational areas. The trucks should enter the storage area, reverse and back-tip the soil load starting at the furthest point of the mound from the point of access. The back-acting excavator pulls up the soil into a mound of the required dimensions. The excavator operates by standing on the mound (Figure 2.1). The excavator bucket can be used to shape and firm the sides as the mound is progressively formed to promote the shedding of rain; particularly at the end of each day, but also on the onset of rain during the day. This should include any exposed incomplete surfaces.
- 2.6 The process is repeated with the tipping of soil against the forming mound, and without wheels traversing onto previously tipped material. The operation continues progressively along the main axis of the mound.
- 2.7 Without the trucks rising onto the soil mound, the maximum possible height is related to the boom reach of the excavator (typically 3-4m).
- 2.8 To raise the mound higher, the trucks will have to travel on the upper surface of the mounded soils. In this case the mound should be raised to its maximum height (Figure 2.2). A ramp will have to be provided for the trucks to rise onto the surface of the first tier, which should be capable of trafficking without difficulty. The next tier would be formed repeating the process described above. If further tiers are required, the process would be repeated.
- 2.9 Any exposed edges/surfaces should be shaped using the excavator bucket on the onset of rain during the day. All surfaces should be shaped to shed water

at the end of the day. The final outer surface should be progressively shaped using the excavator bucket to promote the shedding of rain.

- 2.10 Work should stop in wet conditions with measures undertaken to prevent ponding at the base of the mound and on the basal layer. At the start of each day ensure there is no ponding on the basal layers and operating areas.

### Operational Variations

- 2.11 If front loading machines are to be used to excavate multi-tier mounds (Sheet 3), then the compacted inter-tier layer must be sequentially decompact at the building stage by the method described in Sheet 18.

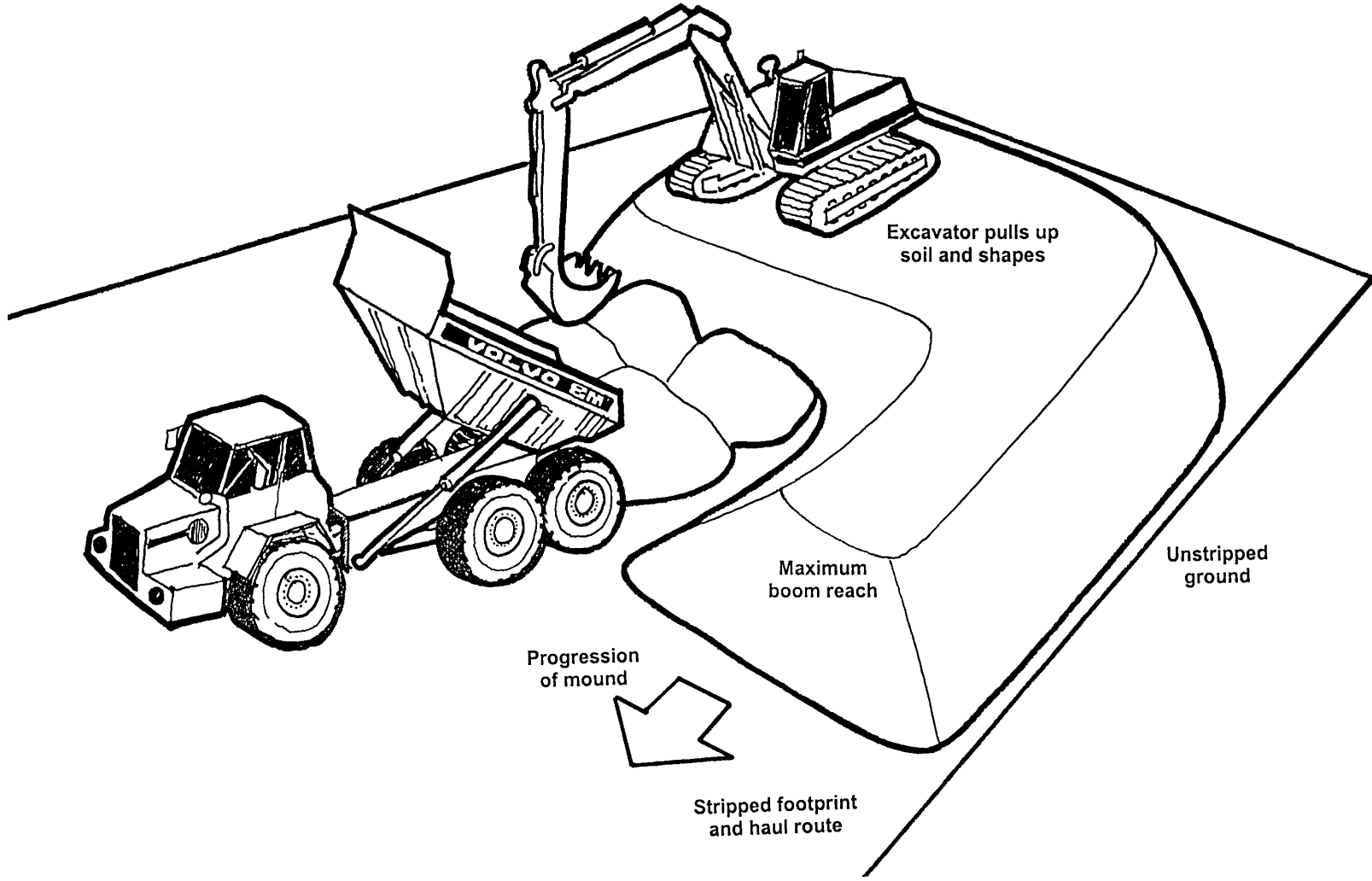

**Figure 2.1 Soil storage mound construction with excavators and dump trucks: Single tier mound**

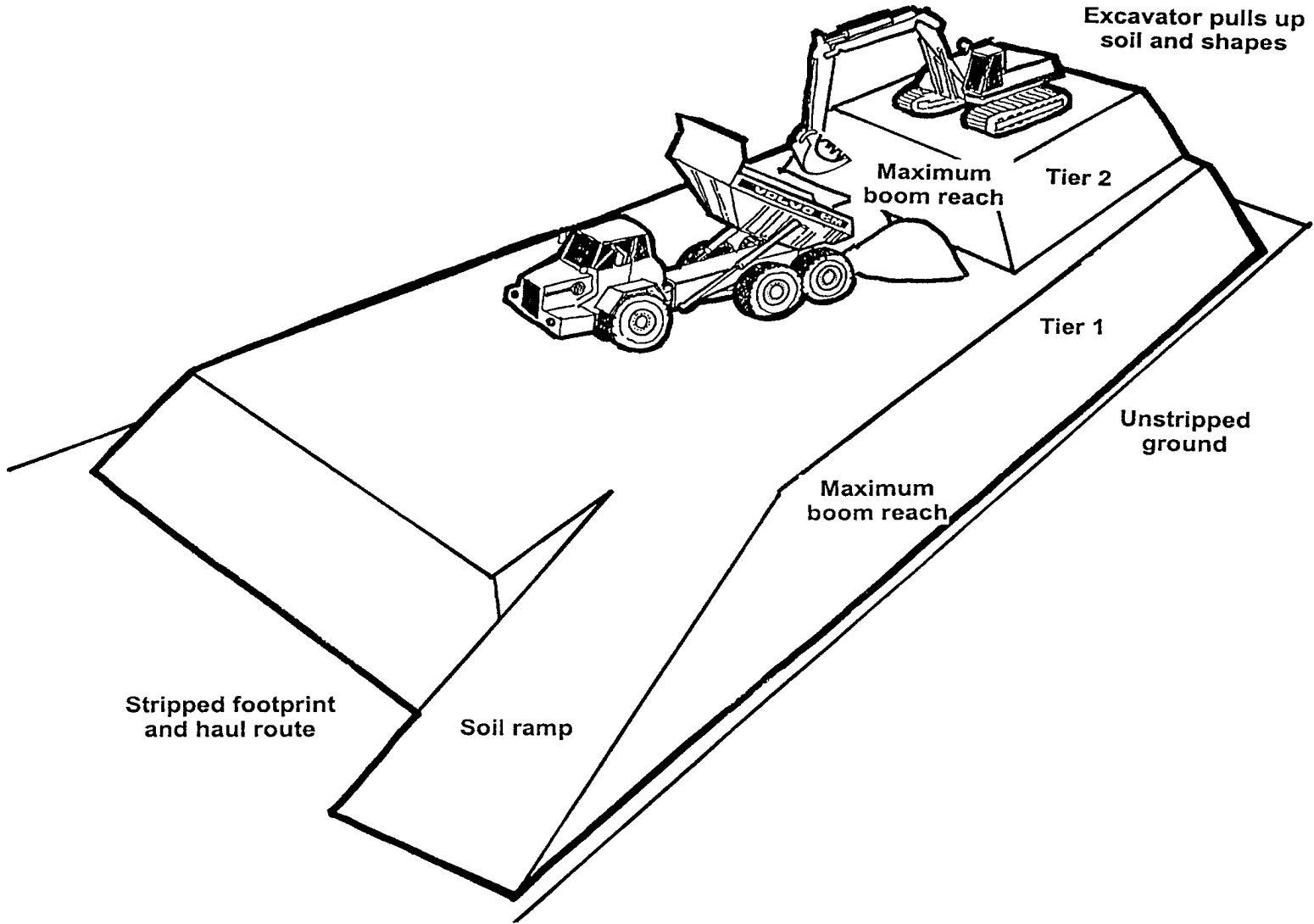

**Figure 2.2 Soil storage mound construction with excavators and dump trucks:  
Multi-tier mound**

**SHEET 2**

**Version: 04/00**

**FEEDBACK**

**It would be most helpful in assessing access to this Guidance, the use made of it and its further development if the following could be completed and returned to the FRCA:**

<b><u>Organisation</u></b>			
<b><u>Contact Name</u></b>			
<b><u>Telephone/e-mail</u></b>			<b><u>Date</u></b> <input type="text"/>

**Is the Guidance to be used generally or for specific site/works?**

**General**  **Specific site**

**If specific site – please identify**

**Name**  **County**  **Country**

**How was the Guidance obtained?**

**Internet**  **FRCA**  **Other**

**If other – please identify source**

**Source of Guidance**

**When was the Guidance obtained?**

**Month**  **Year**

**Please provide any helpful comment/experience which may benefit the Guidance (use additional sheets if necessary)**

--

**Please copy and return to: M Stephen, Farming and Rural Conservation Agency, Rural Development Team, Government Buildings, Block C, Brooklands Avenue, Cambridge CB2 2BL, UK**



# **GOOD PRACTICE GUIDE FOR HANDLING SOILS**

## **Sheet 3:**

### **Excavation of Soil Storage Mounds with Excavators and Dump Trucks**

**Issued by the Farming and Rural Conservation Agency, Cambridge**

**April 2000**



## MAFF FOREWORD

Standards of restoration of minerals and waste sites have steadily improved in recent years, with operators increasingly aware of their environmental responsibilities. The industry is putting forward more imaginative restoration concepts to a variety of afteruses, and is more aware than ever that it will be judged on the standard of that restoration, and the sustainability of the development.

Sustainable mineral development means balancing economic, environmental and social needs, whilst using resources wisely. The UK Strategy for Sustainable Development recognises the importance of safeguarding agricultural land to meet the needs of future generations, and minimising the loss of soils to new development\*.

Improved restoration standards have sometimes enabled planning permission to be given for best and most versatile agricultural land to be worked for minerals, on the basis that it can be restored in a way that safeguards its long-term agricultural potential\*\*. Inherent in these high standards of restoration is the requirement to handle soils in such a way that damage to their structure is minimised. It is the aim of this Guide to provide comprehensive advice on soil handling “Good Practice” to operators, soil moving contractors, consultants and planning authorities.

The Guide is in the form of 15 Sheets giving advice on soil stripping, the forming and taking down of soil storage mounds, and soil replacement operations using excavators, earth scrapers or bulldozers. There are also four Guidance Sheets on remedial works involving the removal of stones and damaging materials, and decompaction during the replacement operations.

This document should be cited as MAFF (2000), Good Practice Guide for Handling Soils (version 04/00). FRCA, Cambridge.

**Any views expressed in the guidance are those of the consultant and do not necessarily represent the view of the Ministry of Agriculture, Fisheries and Food.**

\*(DETR, A Better Quality of Life, May 1999, paragraphs 6.66 and 8.50)

\*\*MPG7 (November 1996, paragraph 3).

### Acknowledgements

The Guide was written and prepared by Dr R N Humphries of Humphries Rowell Associates, Charnwood House, Loughborough, LE11 3NP, UK. The art work was by R Shenton of H J Banks & Co.

### **SHEET 3 EXCAVATION OF SOIL STORAGE MOUNDS WITH EXCAVATORS & DUMP TRUCKS**

The purpose of this Guidance Sheet is to provide a model method for best practice where excavators and dump trucks are used to excavate soil storage mounds. This Guidance Sheet comprises 4 pages of text, 3 figures and a user response form.

The model may need to be modified according to site conditions or requirements of the Planning Authority. Where this is the case, deviation from the model should be recorded with reasons. The guidance does not specify the type, size or model of equipment, but this should have been agreed as part of the planning conditions or as a reserved matter. The machines should be of a kind which will cause the minimum compaction whilst being operationally efficient (eg wide tracked), and must be well maintained at all times.

Persons involved in the handling of soils, overburden etc., and in the construction or removal of mounds or tips, must comply with the Health and Safety at Work Etc. Act 1974 and its relevant statutory provisions, and in particular those aspects which relate to the construction and removal of tips, mounds and similar structures. This requirement takes preference over any suggested practice in the Sheets.

The user of these guidelines is solely responsible for all liabilities that might arise. No liabilities are accepted for any losses of any kind arising from the use of this guidance.

This soil handling method uses back-acting excavators to load the soil in to dump trucks (articulated or rigid bodied) for transport to the replacement areas.

The soil handling method can affect the agricultural quality of the restoration through severe soil deformation (compression and smearing). This is primarily caused through trafficking, the effects of which increases with increasing soil wetness.

The advantage of this model method, if correctly carried out, is that it should avoid severe deformation of the soil as trafficking is minimised. However, where the soil has been stored in multi-tier mounds there will be a need for decompaction treatment during the excavation operation (see below and Sheet 18).

The key operational points to ensure avoidance of severe soil deformation are as follows:

- (i) To minimise compaction:
  - the dump trucks must only operate on the 'basal'/non-soil layer, and their wheels must not on any circumstances run on to the soil in store.
  - the excavator should only operate on the soil mound.
  - the machines are to only work when ground conditions enable their maximum operating efficiency.
  - when excavating the multi-tier mounds, excavate tier by tier starting with the uppermost, trafficking is to be confined to the upper surface of the next tier.
  - if compaction has been caused then measures are required to treat it before it is loaded into the trucks (see below and Sheet 18).
- (ii) To minimise soil wetness and rewetting:
  - the mound should be shaped to shed water before rainfall occurs and whenever replacement is suspended.
  - measures are required to protect the face of the soil layer from ponding of water and maintain the basal layer in a condition capable of supporting dump trucks.

## The Excavation Operation

- 3.1 The dump trucks are to travel only on haul routes and in operational area, and both must be maintained. In the case of single tier mounds they must only operate on the basal layer. Detailed daily records should be kept of operations undertaken, and site and soil conditions.
- 3.2 The trucks should enter the storage area and draw alongside the active excavation face. If back-acting excavators are used, they will need to stand on top of the mound to load trucks (Figure 3.1). The mound is to be dug to the base before moving progressively back along its axis.
- 3.3 With multi-tier mounds, the soil should be excavated tier by tier starting with the uppermost tier. This will necessitate the running of the trucks on the stored soil. Excavation should be in the same height of tiers as originally built so that the same surfaces are used for trafficking to minimise further compaction (Figure 3.2). Having removed an upper tier the trafficked layer must be decompacted. This can be achieved by progressively digging the surface as described on Sheet 18 in advance of loading the next layer. It is essential that the digging is effective and this needs to be systematically tested before soil is loaded. The process is repeated for each soil tier.
- 3.4 Any exposed edges/surfaces should be shaped on the onset of rain during the day. All surfaces should be shaped to shed water at the end of each day.
- 3.5 Work should stop in wet conditions with measures undertaken to prevent ponding at the base of the mound and on the basal layer. At the start of each day ensure there is no ponding on the basal layer and operating areas.

## Operational Variations

- 3.6 Front loading machines may be used to excavate single tier soil mounds provided that they only operate on the basal layer with the dump trucks (Figure 3.3).
- 3.7 Front loading machines are only to be used for multi-tier mounds if the compacted inter-tier layer has been decompactd at the building stage.

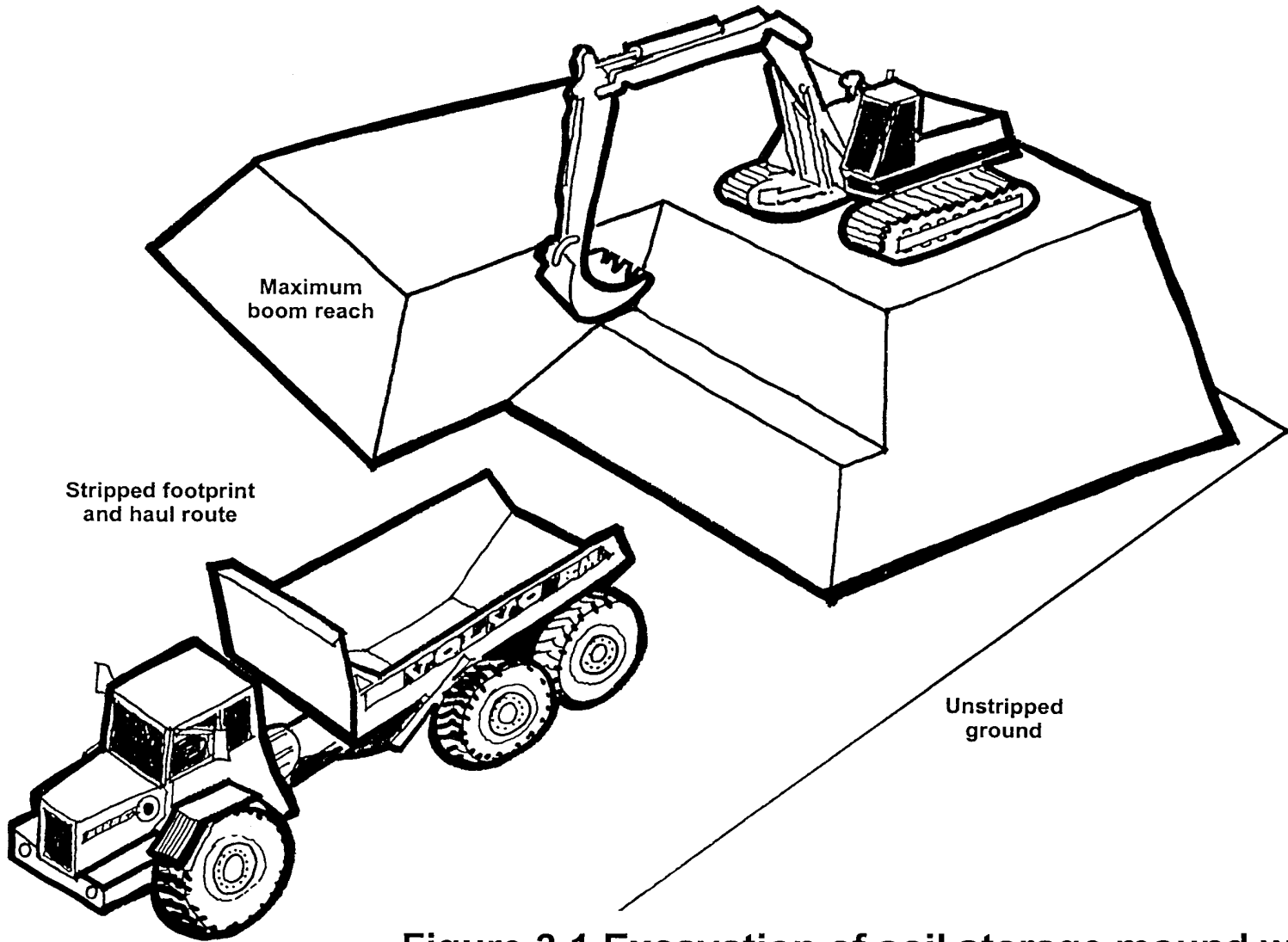

**Figure 3.1 Excavation of soil storage mound with excavators and dump trucks:  
Single tier mound**

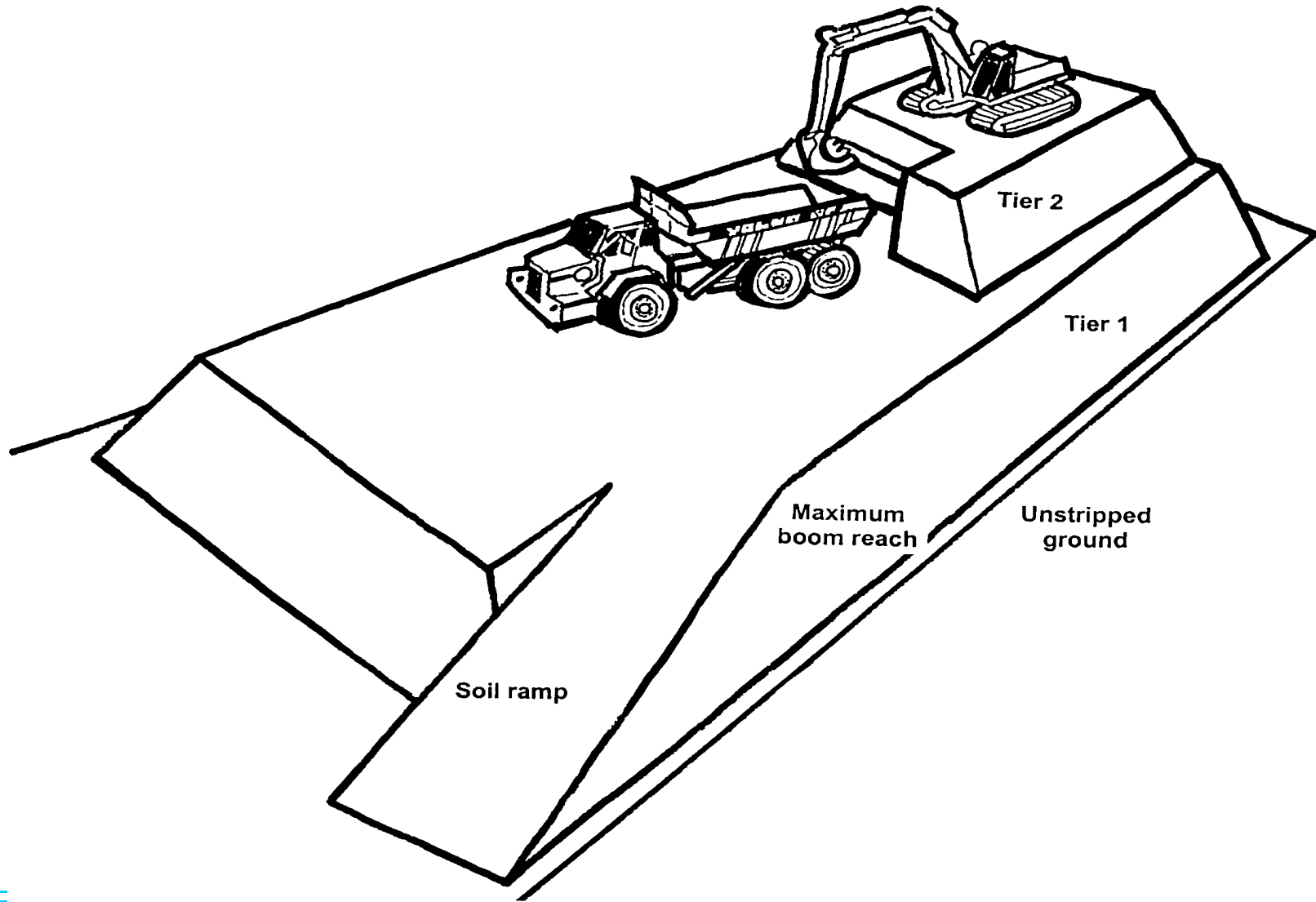

**Figure 3.2 Excavation of soil storage mound with excavators and dump trucks:  
Multi-tier mounds**

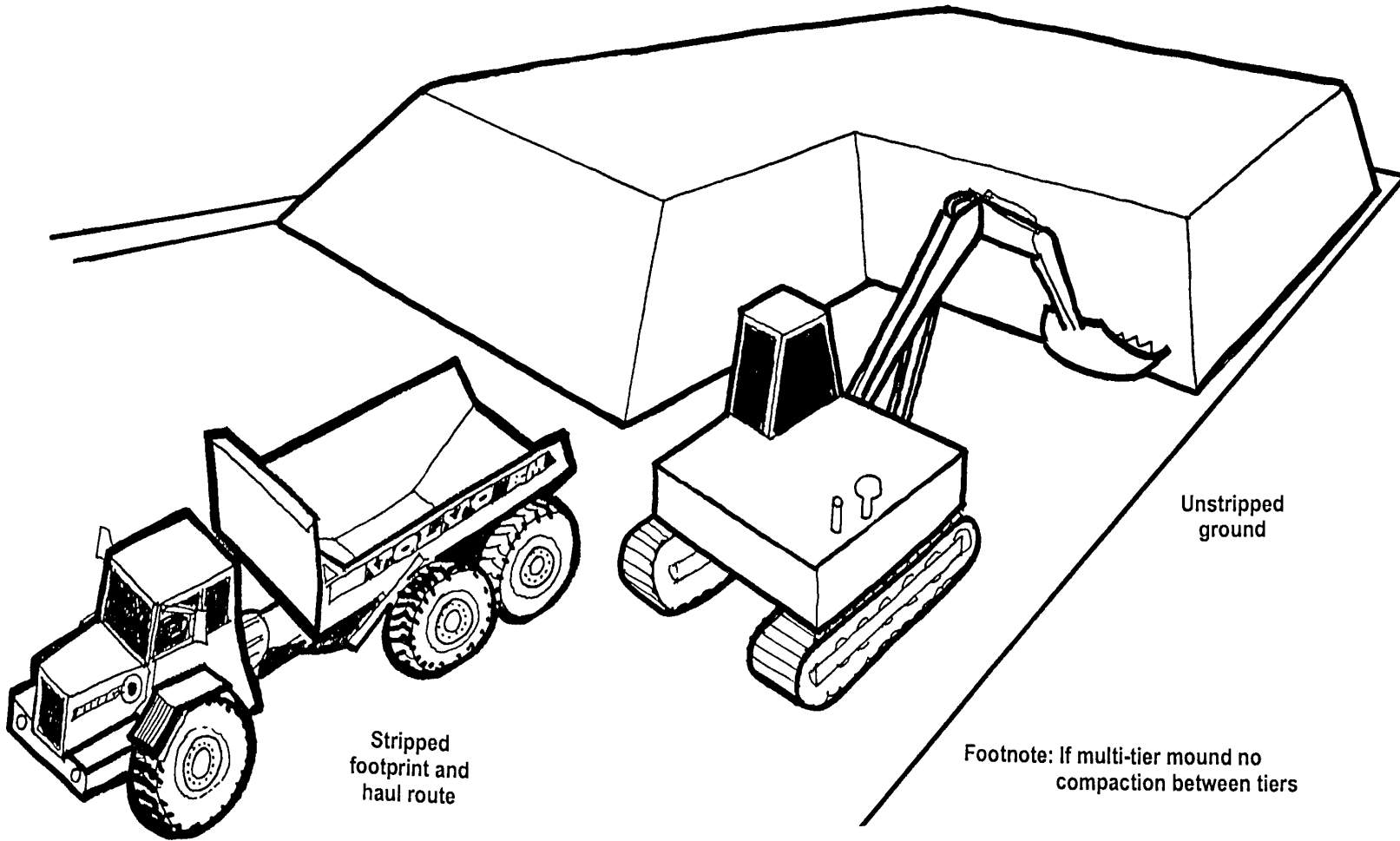

**Figure 3.3 Excavation of soil storage mounds with front loading shovels and dump trucks: Single and multi-tier mounds**



**SHEET 3**

**Version: 04/00**

**FEEDBACK**

**It would be most helpful in assessing access to this Guidance, the use made of it and its further development if the following could be completed and returned to the FRCA:**

<b><u>Organisation</u></b>	<input type="text"/>	
<b><u>Contact Name</u></b>	<input type="text"/>	
<b><u>Telephone/e-mail</u></b>	<input type="text"/>	<b><u>Date</u></b> <input type="text"/>

**Is the Guidance to be used generally or for specific site/works?**

**General**  **Specific site**

**If specific site – please identify**

**Name**  **County**  **Country**

**How was the Guidance obtained?**

**Internet**  **FRCA**  **Other**

**If other – please identify source**

**Source of Guidance**

**When was the Guidance obtained?**

**Month**  **Year**

**Please provide any helpful comment/experience which may benefit the Guidance** (use additional sheets if necessary)

<input type="text"/>
<input type="text"/>

**Please copy and return to: M Stephen, Farming and Rural Conservation Agency, Rural Development Team, Government Buildings, Block C, Brooklands Avenue, Cambridge CB2 2BL, UK**



# **GOOD PRACTICE GUIDE FOR HANDLING SOILS**

## **Sheet 4:**

### **Soil Replacement with Excavators and Dump Trucks**

**Issued by the Farming and Rural Conservation Agency, Cambridge**

**April 2000**

## **MAFF FOREWORD**

Standards of restoration of minerals and waste sites have steadily improved in recent years, with operators increasingly aware of their environmental responsibilities. The industry is putting forward more imaginative restoration concepts to a variety of afteruses, and is more aware than ever that it will be judged on the standard of that restoration, and the sustainability of the development.

Sustainable mineral development means balancing economic, environmental and social needs, whilst using resources wisely. The UK Strategy for Sustainable Development recognises the importance of safeguarding agricultural land to meet the needs of future generations, and minimising the loss of soils to new development\*.

Improved restoration standards have sometimes enabled planning permission to be given for best and most versatile agricultural land to be worked for minerals, on the basis that it can be restored in a way that safeguards its long-term agricultural potential\*\*. Inherent in these high standards of restoration is the requirement to handle soils in such a way that damage to their structure is minimised. It is the aim of this Guide to provide comprehensive advice on soil handling “Good Practice” to operators, soil moving contractors, consultants and planning authorities.

The Guide is in the form of 15 Sheets giving advice on soil stripping, the forming and taking down of soil storage mounds, and soil replacement operations using excavators, earth scrapers or bulldozers. There are also four Guidance Sheets on remedial works involving the removal of stones and damaging materials, and decompaction during the replacement operations.

This document should be cited as MAFF (2000), Good Practice Guide for Handling Soils (version 04/00). FRCA, Cambridge.

**Any views expressed in the guidance are those of the consultant and do not necessarily represent the view of the Ministry of Agriculture, Fisheries and Food.**

\*(DETR, A Better Quality of Life, May 1999, paragraphs 6.66 and 8.50)

\*\*MPG7 (November 1996, paragraph 3).

### **Acknowledgements**

The Guide was written and prepared by Dr R N Humphries of Humphries Rowell Associates, Charnwood House, Loughborough, LE11 3NP, UK. The art work was by R Shenton of H J Banks & Co.

## **SHEET 4 SOIL REPLACEMENT WITH EXCAVATOR & DUMP TRUCK**

The purpose of this Guidance Sheet is to provide a model method for best practice where soils are to be replaced by excavators and dump trucks. This Guidance Sheet comprises 7 pages of text, 4 figures and a user response form.

The model may need to be modified according to site conditions or requirements of the Planning Authority. Where this is the case, deviation from the model should be recorded with reasons. The guidance does not specify the type, size or model of equipment, but this should have been agreed as part of the planning conditions or as a reserved matter. The machines should be of a kind which will cause the minimum compaction whilst being operationally efficient (eg wide tracked), and must be well maintained at all times.

Persons involved in the handling of soils, overburden etc., and in the construction or removal of mounds or tips, must comply with the Health and Safety at Work Etc. Act 1974 and its relevant statutory provisions, and in particular those aspects which relate to the construction and removal of tips, mounds and similar structures. This requirement takes preference over any suggested practice in the Sheets.

The user of these guidelines is solely responsible for all liabilities that might arise. No liabilities are accepted for any losses of any kind arising from the use of this guidance.

This soil handling method uses back-acting excavators in combination with dump trucks (articulated or rigid bodied). An excavator is used to spread the soil tipped from dump trucks used for transportation to replacement areas.

The soil handling method can affect the agricultural quality of the restoration through severe soil deformation (compression and smearing). This is primarily caused through trafficking, the effects of which increases with increasing soil wetness.

The advantage of this model method, if correctly carried out, is that it should avoid severe deformation of the soil as trafficking is minimised. Consequently, there should normally be no need for decompaction treatment during the replacement operation, unless the soils are in a compacted state following stripping or storage. Where compaction occurs at replacement this will need treatment during the replacement process. Also where required, it will be necessary to integrate the removal of stones or damaging materials with the replacement process. Both decompaction and removal of materials are covered in separate Guidance Sheets (16-19).

The early installation of under drainage is strongly recommended. Where required this should either be undertaken sequentially during the replacement of the soils or in the early aftercare period. Until drains are installed it is recommended that the restored land is sown and managed as grassland.

The key operational points to ensure avoidance of severe soil deformation are as follows:

- (i) To minimise compaction:
  - the dump trucks must only operate on the 'basal'/non-soil layer, and their wheels must not on any circumstances run on to the soil layer(s).
  - the excavator must only operate on the basal layer.
  - the adoption of a bed/strip system avoids the need for the trucks and excavator to travel on the soil layers.
  - the machines are to only work when ground conditions enable their maximum operating efficiency.
  - if compaction has been caused, then measures are required to treat it (see Sheets 18 & 19).

- (ii) To minimise soil wetness and rewetting:
- the bed/strip system provides a basis to regulate the exposure of lower soil layers to periods of rain and a means of maintaining soil moisture contents. The soil profile within the active strip should be completed to the topsoil layer before rainfall occurs and before replacement is suspended.
  - measures are required to protect the face of the soil layer from ponding of water and maintain the basal layer in a condition capable of supporting dump trucks.

### The Replacement Operation

- 4.1 The area to be restored is to be protected from in-flow of water, ponding etc. Wet sites must be drained in advance. Before the operation starts the basal layer should be to level and clean.
- 4.2 Prior to commencing operations a Meteorological Office forecast should be obtained which gives reasonable confidence of soil replacement proceeding without interruptions from rainfall events. If significant rainfall occurs during operations, the replacement must be suspended, and where the soil profile has been started it should be replaced to topsoil level. Replacement must not restart unless the weather forecast is expected to be dry for at least a full day.
- 4.3 All machines must be in a safe and efficient working condition at all times. The machines are to only work when ground conditions enable their maximum operating efficiency. The operation should only be carried out when the basal layer supports the machinery without ruts or is capable of repair/maintenance. The operation is to be suspended before traction becomes a problem or the integrity of the basal layer and haul routes fails.

- 4.4 The operation should follow a detailed replacement plan showing soil units to be replaced, haul routes and the phasing of vehicle movements. The soil units should be defined on the site with information to distinguish types and layers, and thickness. Detailed daily records should be kept of operations undertaken (including the removal of stones and other damaging materials, and the results of any assessment of the need for additional decompaction and effectiveness of decompaction work undertaken), and site and soil conditions.
- 4.5 The excavator and dump trucks are only to stand, work and travel on the basal/formation layer.
- 4.6 The soil layers above the base/formation layer are to be replaced in sequential strips with the subsoil layer(s) replaced first, followed by the topsoil layer; each layer being replaced to the specified thickness. The next strip is not to be started until the profile in the current strip is completed. This is often referred to as the 'bed or strip system'. The system involves the progressive sequential laying of the materials in strips across the area to be restored (Figure 4.1).
- 4.7 The initial strip width and axis is to be demarcated. Strip width is determined by excavator boom length less the stand-off to operate; typically about 5-8m. Effective boom length can also reduce with profile heights greater than 1m; at 1.5m the effective reach of the standard boom may result in only 2m wide strips. A wide bucket with a blade and not teeth should be used to spread the soil.
- 4.8 Reverse dump truck up to edge of the current strip and tip the lowest layer (subsoil) soil, without the wheels riding onto the strip (Figure 4.1). The dump truck should not drive away until all the soil is deposited within the strip without spillage over the basal layer; this may require assistance from the excavator to 'dig away' some of the tipped soil (Figure 4.2). The excavator is to spread the tipped soil to full thickness by digging, and the pushing and

pulling action of bucket. Each load of soil should be spread following tipping, before another is tipped. Should the spread soil comprise of large blocks (>300mm), normally these should be broken down by using the excavator bucket to 'slice' the blocks into smaller pieces (see Sheet 18) before the next load is spread. The process is repeated from left to right until the strip is completely covered with the required depth of the soil layer (Figure 4.3). Alternatively, decompaction by ripping should be undertaken once the strip is complete (see Sheet 19). Decompaction work must be completed before the next soil layer is placed.

- 4.9 Level boards and soil pits should be used to verify soil thickness in each strip and overall levels. Allowances (ie. a bulking factor) should be made for any settlement that may take place of the replaced loose soil.
- 4.10 Where stones are to be removed as part of the replacement process, normally the method described in Sheet 16 should be used once the strip is complete. An alternative method and one suited to removing potentially damaging materials (eg wire ropes) is described in Sheet 17. These operations must be completed before the next soil layer is placed.
- 4.11 On completion of the lowest (subsoil) layer, repeat the process spreading the next layer (subsoil/topsoil) (Figure 4.4). Tip the soil by reversing to the outer edge of strip/soil previously laid, but without the truck wheels riding onto the already placed layer. The soil is to be spread by the excavator to full thickness by digging, and the pushing and pulling action of bucket described above, and undertaking any necessary decompaction work and removal of stones if using Sheets 16 to 19. Repeat the process progressively (left to right) along the strip and undertake any removal of damaging materials or decompaction. Level boards should be used to verify soil thickness in strip and overall levels.
- 4.12 Where the profile is made up of further soil layers (subsoil/topsoil) the process outlined above should be repeated on completion of the strip.



- 4.13 On completion of topsoil layer the processes outlined above should be repeated for the next strips until the area to be restored is completed. Before the operation starts the basal layer should be to level and clean.
- 4.14 At the end of each day the current strip must be completed if rain is forecast. If during a day it is evident that a full strip cannot be completed, then only start part of a strip; this too must be completed.
- 4.15 At the end of each day, or during the day if interrupted by rain, make provisions to protect base of restored strip from ponding/runoff by sumps and grips, and also clean and level the basal layer. At the start of each day ensure there is no ponding in the current strip or operating areas, and the basal layer is to level with no ruts.

#### Operational Variations

- 4.16 When the replaced soil profiles reach about 0.6-1m in height it may not be possible to discharge the load from some dump trucks directly onto the previously placed layers because of the height of the dump truck body. The preferred solution is to tip the soil against the partially completed profile as heaps without the dump trucks rising onto or reversing into the placed material. The soil material is then lifted by the excavator onto the profile. It is considered preferable to accept some limited soil losses rather than to contaminate the topsoil with overburden. The loss of topsoil is minimised if the basal/ formation layer is kept to level and clean.
- 4.16 If the basal/formation layer is to be decompacted, before any soil material is placed, each strip is to be firstly decompacted before the subsoil layer is replaced using either methods described in Sheets 18 or 19. The basal layer must only be decompacted in the strip required for soil replacement, and must



only be prepared on the day of soil placement. During this process it may be necessary to use Sheets 16 or 17 for the removal of stones or damaging materials from the decompacted basal layer.

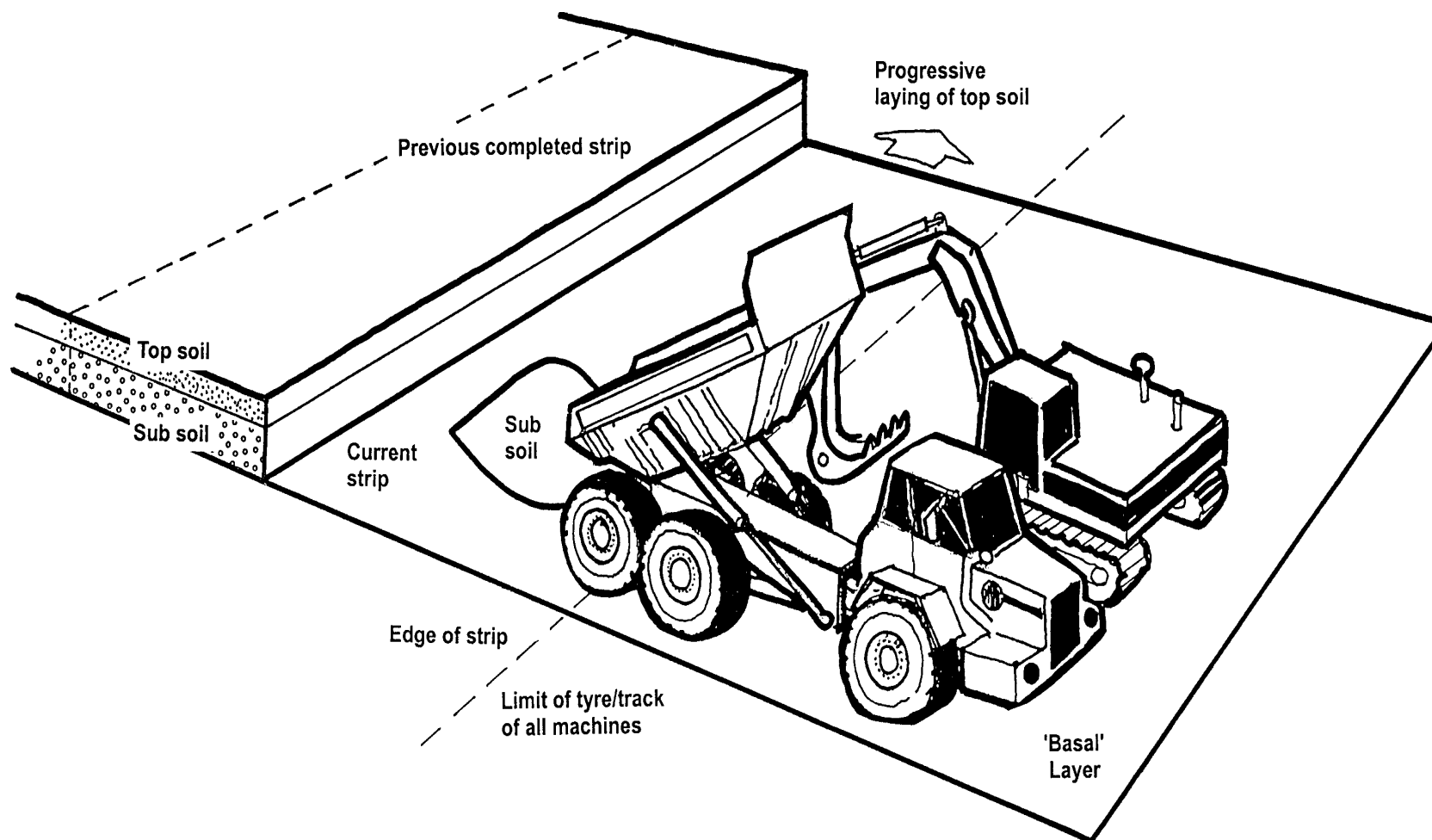

**Figure 4.1 Soil replacement with excavators and dump trucks:  
Sub soil layer**

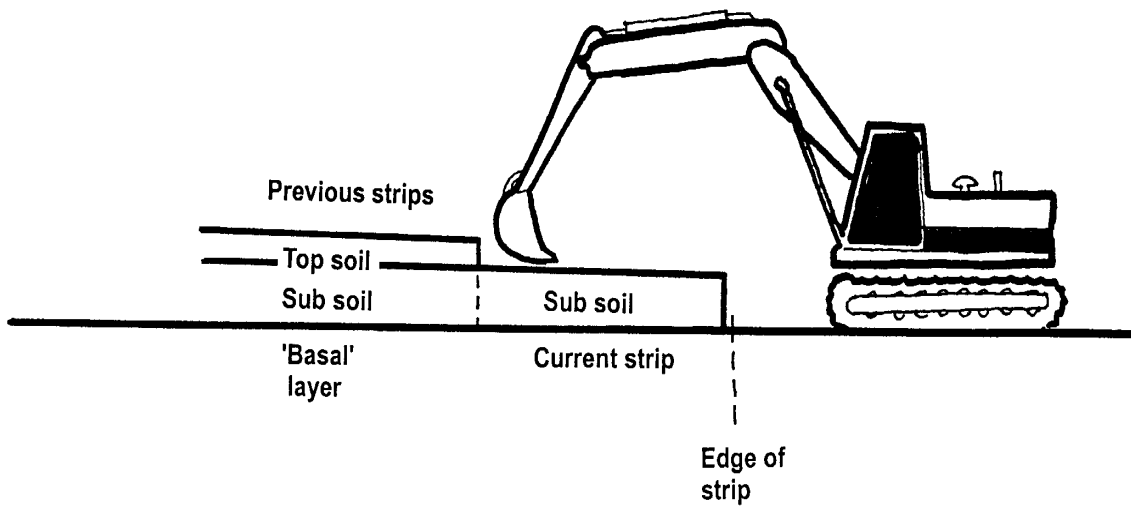
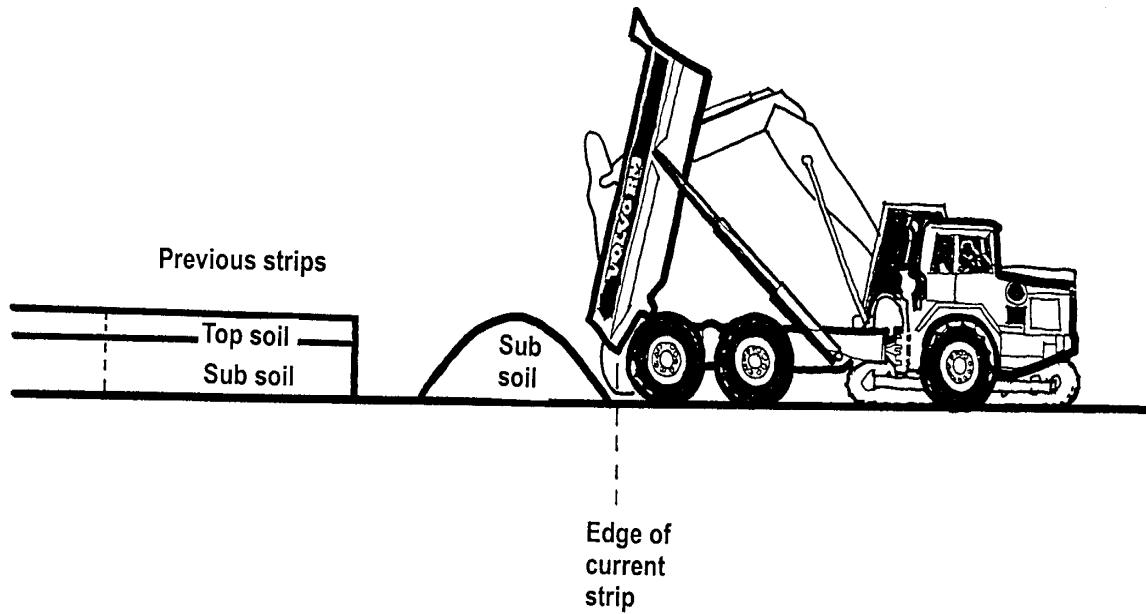

**Figure 4.2 Soil replacement with  
excavators - dump trucks  
Sub soil layer**

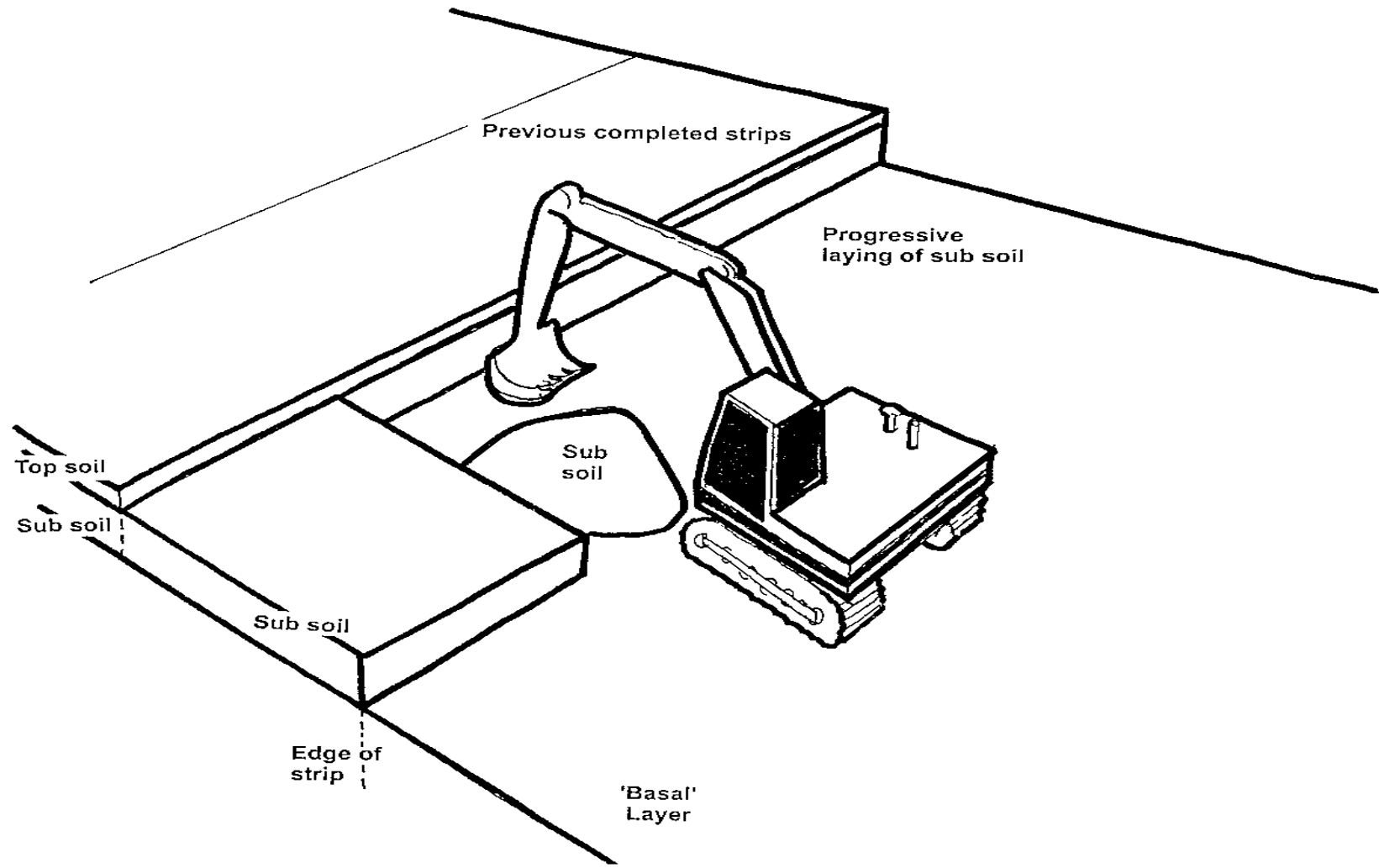

**Figure 4.3 Soil replacement with excavators and dump trucks:  
Sub soil progressively laid**

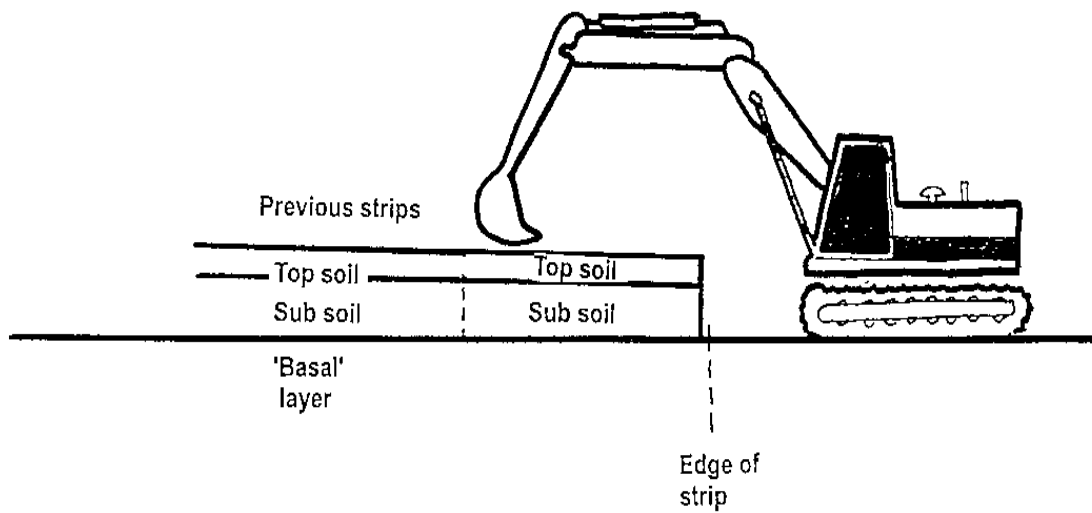
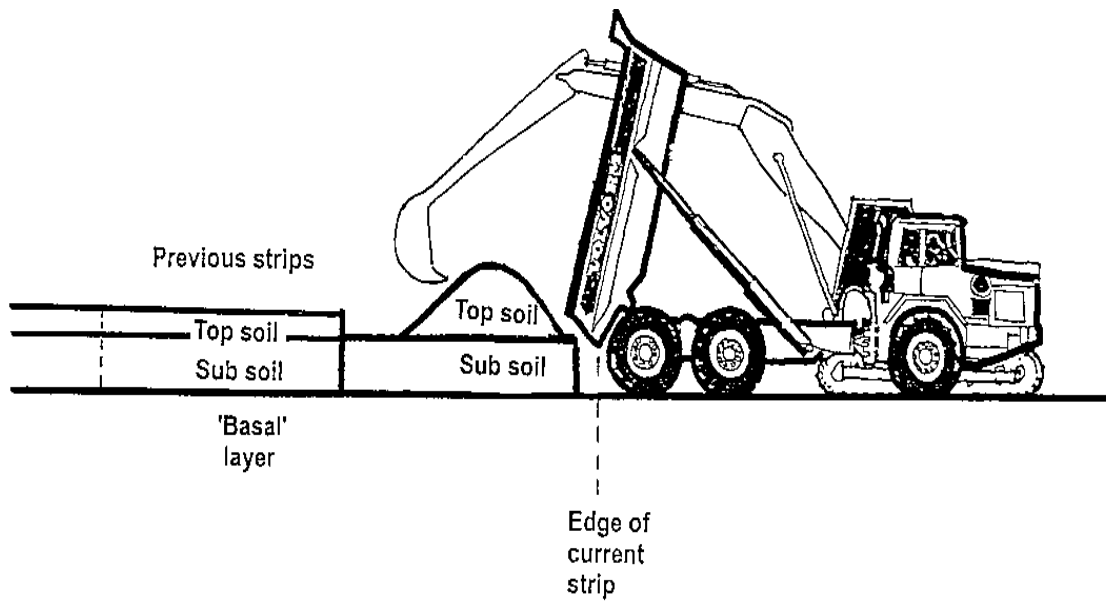

**Figure 4.4 Soil replacement with excavators and dump trucks:  
Top soil layer**

**SHEET 4**

**Version: 04/00**

**FEEDBACK**

**It would be most helpful in assessing access to this Guidance, the use made of it and its further development if the following could be completed and returned to the FRCA:**

<b><u>Organisation</u></b>	<input type="text"/>	
<b><u>Contact Name</u></b>	<input type="text"/>	
<b><u>Telephone/e-mail</u></b>	<input type="text"/>	<b><u>Date</u></b> <input type="text"/>

**Is the Guidance to be used generally or for specific site/works?**

**General**  **Specific site**

**If specific site – please identify**

**Name**  **County**  **Country**

**How was the Guidance obtained?**

**Internet**  **FRCA**  **Other**

**If other – please identify source**

**Source of Guidance**

**When was the Guidance obtained?**

**Month**  **Year**

**Please provide any helpful comment/experience which may benefit the Guidance** (use additional sheets if necessary)

<input type="text"/>
<input type="text"/>

**Please copy and return to: M Stephen, Farming and Rural Conservation Agency, Rural Development Team, Government Buildings, Block C, Brooklands Avenue, Cambridge CB2 2BL, UK**

## Annex DEC I2

### Bird Hazard Management Plan

- I1. In the Scoping Opinion provided by PINS in August 2020 the Ministry of Defence scoping response stated that:

*'The stripping and handling of top soils can expose invertebrates, resulting in feeding opportunities for hazardous birds such as corvids and gulls. As such, at any development near an aerodrome which involves earthworks a Bird Hazard Management Plan (BHMP) is recommended to ensure that the handling of top soil does not result in a transitory attractant for hazardous birds.'*

#### Results of the bird surveys undertaken at the site

- I2. Twelve passage/wintering bird surveys of the proposed western extension were undertaken between October 2018 and March 2019, comprising a combination of dawn and dusk visits with walked transects and vantage point counts. The passage/wintering bird survey recorded 37 species, mainly passerines, feeding in the arable fields and hedgerows. Wintering and passage birds are the most dangerous groups of birds with respect to aircraft bird strike. The site is not known for large passage/wintering bird flocks and this was confirmed by the wintering bird surveys.
- I3. From March to June 2019, six breeding and summering bird survey visits were undertaken by walking all habitats within the proposed western extension area, together with the adjacent woodland boundaries. Three breeding bird survey visits were also made to the existing ENRMF from April to June 2019. The 2019 summer bird surveys at the western extension and existing ENRMF recorded 45 species and 34 species respectively comprising small birds such as finches, robins, warblers and the occasional skylark. None of these birds flock.



14. The site has no large water bodies therefore does not hold wildfowl or waders and the site does not attract gulls or large winter roosts of bird such as corvids or pigeons. The site has only scattered berry trees so does not attract winter thrushes and other than occasional red kites the breeding bird population comprises mainly woodland and arable passerines.

### **Proposals at the site**

15. The topsoil stripping will be undertaken on a phased basis. The topsoil and subsoil will be stripped and stored on Phases 19 to 21 in accordance with the Soil Handling and Management Scheme (Appendix DEC I). Mineral and overburden extracted as a result of the creation of the landfill cells also will be stockpiled on Phases 19 to 21. During the period when topsoil and subsoil is stripped from each phase there will be regular activity from mobile plant such as backacter excavators and dump trucks moving material around the site.
16. It is not anticipated that there will be a significant increase in hazardous bird species or bird congregations at the site as a result of the topsoil stripping during the limited periods over which each phase of soil stripping will take place. The existing agricultural operations on the western extension area including ploughing has not attracted significant groups of birds.

### **Monitoring**

17. Monitoring will be undertaken during the topsoil stripping operations to identify if birds or congregations of birds considered to be potentially hazardous to aircraft using the nearby airfield are establishing within the site.

### **Deterrents**

18. if birds or congregations of birds considered to be potentially hazardous to aircraft are establishing within the site deterrents will be deployed to disturb the birds and preventing settlement or roosting such as using audio distress signals or alternative scaring methods.

**APPENDIX DEC J**

**STOCKPILE MANAGEMENT SCHEME  
FIGURE DEC J1 TEMPORARY STOCKPILE LOCATIONS (DRAWING  
REFERENCE AU/KCW/07-21/22693)**

## Appendix DEC J

### Stockpile Management Scheme

J1. This scheme relates only to the management of the clay and overburden stockpiles and identifies the locations for stockpiles of all material. The stockpiles within the waste treatment and recovery facility comprise waste stockpiles that are awaiting treatment, that have been treated and are awaiting landfill or are awaiting transport off site. The waste treatment stockpiles are not covered by this scheme as they are managed through procedures which form part of the Environmental Permit for the waste treatment and recovery facility. The management of soil stockpiles is addressed under the Soil Handling and Management Scheme (Appendix DEC I).

#### **Existing ENRMF**

J2. There is currently material stockpiled on the existing ENRMF. The maximum extent of the stockpile on the existing ENRMF is shown on Figure DEC J1 (drawing reference AU/KCW/07-21/22693). The material comprises excavated clay and overburden which is used on site in the creation of the engineered low permeability lining to the landfill cells, used in the construction of a low permeability capping layer and in the restoration of the site. Material in excess of that needed for site use is exported off site for general sale or reuse elsewhere including at the nearby Augean Thornhaugh Landfill Site.

J3. No further material will be added to the current stockpile on the existing ENRMF after the excavation of Phases 8 and 9 which is due to take place at the end of 2021. The material in the stockpile will be used to line Phases 8 and 9 and to cap previous phases with the remainder gradually removed from the site at a steady rate.

**Proposed western extension**

- J4. During the construction of the proposed western extension all material that is not needed for use in construction and restoration will be exported off site. Wherever possible this will be exported at the time it is excavated rather than stockpiled. However, as the excavation operations will progress at a greater speed than construction or restoration operations It may be necessary to temporarily store clay and overburden on the proposed western extension. The stockpiles will be located in the area of Phase 19 to 21 as shown on Figure DEC J1 prior to the use of the material in the creation of the landfill cells, restoration of the landfill or prior to exportation off site for general sale or reuse elsewhere. It will also be necessary to stockpile soils for use in restoration as specified in the Soil Handling and Management Scheme (Appendix DEC I). The soil stockpiles will also be located in the stockpile areas identified on Figure DEC J1. The height of the stockpiles in the area of Phases 19 to 21 will not exceed the height or profile shown on the Restored Landform Profile Plan (PINS document reference 2.9).
- J5. When site operations in the proposed western extension progress to excavate, construct and fill the landfill areas in Phases 19 to 21, the area available for stockpiling gradually will be reduced and it will become necessary to create a temporary stockpile area in the current ENRMF. In order not to disturb the main area of the existing ENRMF landfill facility which will have been restored by this stage, a temporary stockpile location will be created against the south eastern flank of Phases 4B and 5B at the location shown on Figure DEC J1. This location is considered the least visually intrusive location that can temporarily accommodate the necessary material. This stockpile will extend up to approximately the 95m AOD contour on the flank and will extend outward to the northern edge of the haul road.

**Management of stockpiles**

- J6. All stockpile storage locations that will remain in situ for more than 6 months, or over winter will be seeded with grass and managed in accordance with this scheme. The vegetated stockpiles will be managed and kept free of noxious

weeds where necessary. Cutting or spraying will be undertaken as necessary to control weed growth and prevent the build up of a seed bank of weeds which may disperse within the site and onto adjacent land. The stockpiles will be inspected at least twice a year for the presence of noxious weeds.

- J7. In the event that it is necessary to stockpile materials other than in the locations shown on Figure DEC J1 the storage proposals will be agreed with the Local Planning Authority.

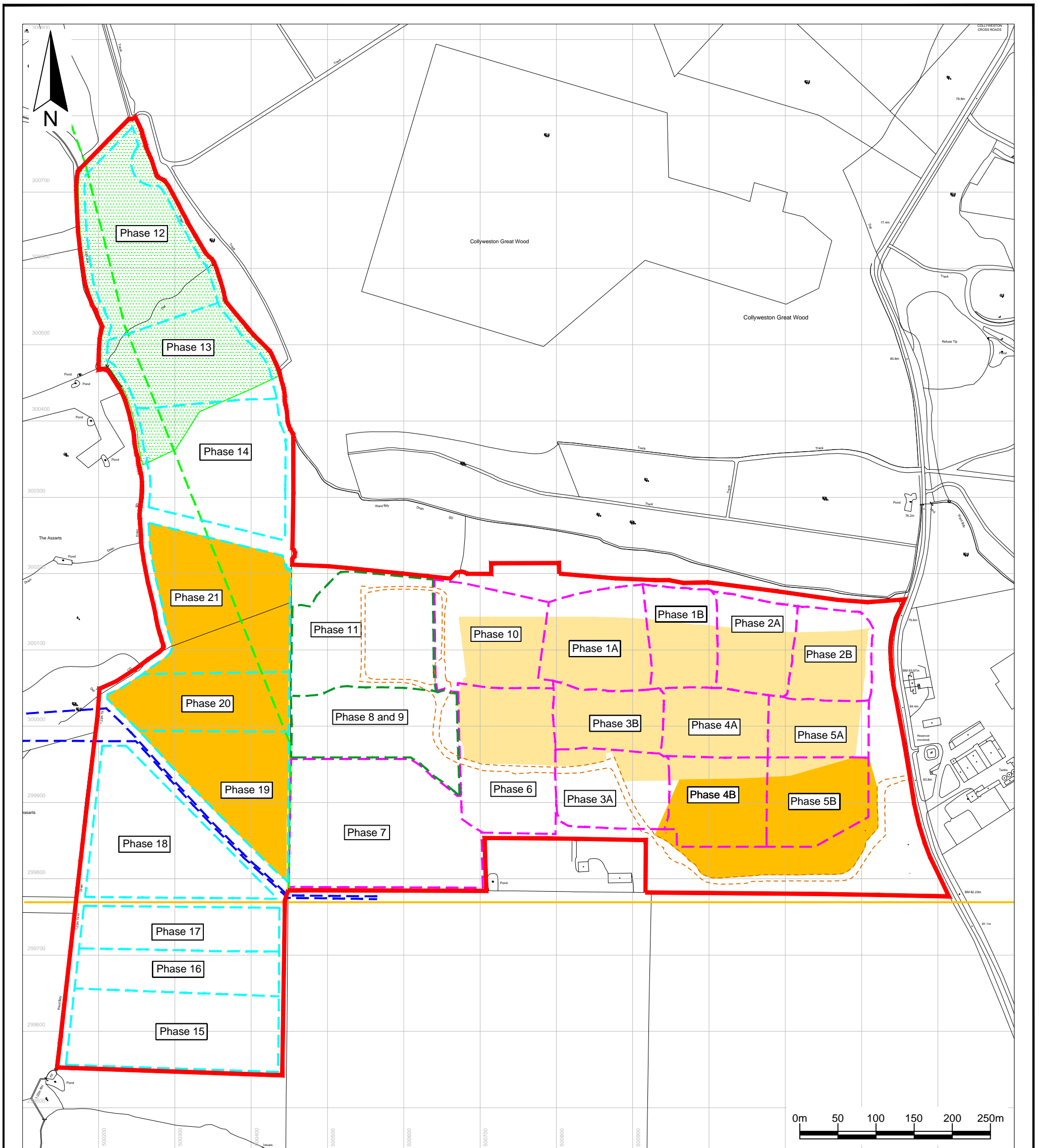

**Key / Notes**

- Boundary of the area the subject of the application for the Development Consent Order
- Approximate phase boundaries for the existing ENRMF already constructed
- Approximate phase boundaries for the existing ENRMF to be constructed
- Approximate phase boundaries to be constructed in the proposed western extension
- Approximate route of water pipelines
- Approximate route of an overhead electricity cable (to be diverted)
- Approximate location of a high pressure gas pipeline
- Temporary stockpiling areas for topsoil, subsoil, overburden and clay from the site operations
- Current stockpile area
- Soils identified as subgrade 3a
- Site access road/main haul road

Rev	Final	KR	SPS	LH	26/07/21
	Status	Drn	App	Chk	Date
Site EAST NORTHANTS RESOURCE MANAGEMENT FACILITY					
Client 					
Title Temporary stockpile locations					
Figure DEC J1				Scale 1:5,000@A3	
Drawing Ref AU/KCW/07-21/22693					

**APPENDIX DEC K**

**TRAFFIC MANAGEMENT PLAN**

**FIGURE DEC K1 TRAFFIC ROUTING PLAN (DRAWING REFERENCE  
AU/KCW/07-21/22694)**





## Appendix DEC K

### Traffic management plan

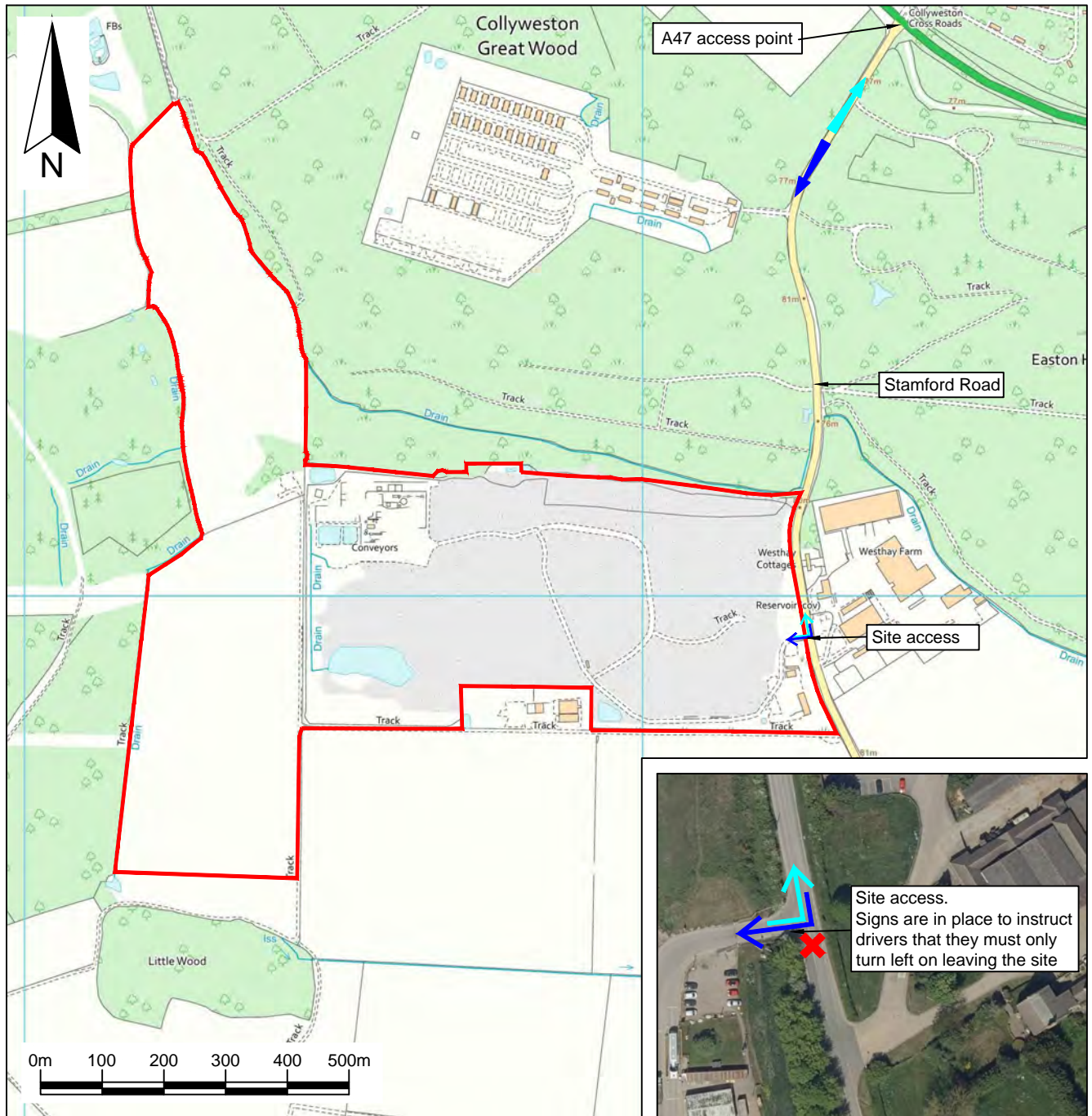
- K1. This scheme controls the movement of Heavy Goods Vehicles (HGVs) to and from the site.
- K2. All HGV traffic entering and leaving the site must access the site from the north via the A47 and Stamford Road (Figure DEC K1 (drawing reference AU/KCW/07-21/22694)). No vehicles associated with the site must travel south of the site access along Stamford Road towards Kings Cliffe unless the route is necessary for the local delivery or collection of materials.
- K3. Signs informing the drivers of the routing agreement shall be maintained in a visible position at the site access.
- K4. Appropriate facilities such as closed circuit cameras will be place so that the direction of HGVs entering and leaving the site can be observed and monitored.
- K5. All HGVs leaving the site will use the wheel cleaning facilities provided prior to leaving the site and joining Stamford Road.



**Key / Notes**

-  Approximate boundary of the area the subject of the application for the Development Consent Order
-  HGVs leaving ENRMF
-  HGVs arriving at ENRMF

	Final	KR	SPS	LH	26/07/21
Rev	Status	Drn	App	Chk	Date
Site EAST NORTANTS RESOURCE MANAGEMENT FACILITY		Client 			
Title Traffic routing plan					
Figure DEC K1				Scale 1:10,000@A4	
Drawing Ref AU/KCW/07-21/22694					
Reproduced scale mapping by permission of Ordnance Survey on behalf of The Controller of Her Majesty's Stationery Office. © Crown copyright 2017. All rights reserved. Licence number 100017818.					

**APPENDIX DEC L**  
**NOISE AND VIBRATION MANAGEMENT PLAN**

## APPENDIX 2

### Noise and Vibration Management Plan

#### 1.0 Introduction

- 1.1 The Noise and Vibration Management Plan (NVMP) outlines the methods by which Augean South Limited will systematically assess and minimise the potential impacts of noise generated by the proposed development at East Northants Resource Management Facility (ENRMF).
- 1.2 The proposed development comprises the construction of new landfill void to the west of the existing landfill facility (the proposed western extension) and the alteration of the restoration profile and the timescale for completion of the existing landfill site in order to integrate the final landscape of the existing site with the western extension. The proposed development also includes an alteration to the waste treatment and recovery facility and an extension of the operational period of the current site activities and the western extension to 2046.
- 1.3 The aims of the NVMP are:
- to prevent pollution and minimise disturbance and annoyance to residents;
  - to develop a control strategy which can be implemented during site operations;
  - to ensure that noise and vibration impacts are considered as part of routine inspections;

- to demonstrate good practice and that all appropriate measures are taken to prevent or, where that is not practicable, to reduce emissions from the operations;
- to consolidate any noise and vibration issues on the site to assist Augean in complying with Planning and Permit conditions;
- to assist the Local Planning Authority in enforcement and complaint responses.

## **2.0 Sources**

2.1 The proposed development comprises the construction of a new landfill void to the west of the existing landfill facility and the alteration of the restoration profile. The proposals also include an alteration to the waste treatment and recovery facility operations and an extension to the operational period of the current site activities and the western extension to 2046.

2.2 The main sources of noise and vibration are detailed below:

- Ongoing processing activities at the waste treatment and recovery facility and associated mobile plant movements;
- Landfill construction and engineering works;
- The winning and working of minerals including the extraction of soil, overburden and clay;
- Stockpiling of materials;
- Infilling of waste;
- Capping and restoration activities;
- Mobile plant movements;
- HGV movements.

### 3.0 Receptors

3.1 The nearest noise and vibration sensitive premises to the site are shown below.



## 4.0 Mitigation

4.1 The following control measures are in place at the existing ENRMF and will continue to be implemented to continue to manage noise and vibration from site operations. These measures demonstrate best practice and minimise any potential impacts:

- The permitted operating hours of the site will be strictly adhered to and effectively communicated to all site staff and subcontractors;
- Plant and machinery will be maintained in good working order and used in accordance with the manufacturer's instructions. Any defective items will not be used. Regular inspections of plant will be undertaken to identify any faults or wear and tear that may be resulting in excessive noise and/or vibration;
- Vehicle routes through the site will be kept maintained and free from defects such as pot-holes. The use of speed humps and steep gradients will be avoided where possible;
- Unnecessary horn usage, excessive revving of engines, rapid acceleration and sharp braking will be avoided. Equipment will be switched off or throttled down to a minimum when not required. Any covers, panels or enclosure doors to engines will be kept closed when the equipment is in use;
- Any cladding or enclosures around plant will be regularly inspected for defects/damage/weathering that may negatively impact upon the sound insulation performance of the structure. Once identified any repairs will be carried in a timely manner;
- The drop height of materials will be minimised where possible;



- Equipment will be located as far from sensitive premises as possible. Plant from which the noise generated is known to be particularly directional will, wherever practicable, be orientated so that the noise is directed away from sensitive areas;
- Plant and vehicles will be started up sequentially rather than all together. Any period of idling required to warm up mobile plant at the start of the working day will be undertaken in locations away from residential premises;
- In the event of any emergency or unforeseen circumstances arising that cause safety to be put at risk, every effort be made to ensure that the work in question is completed as quickly and as quietly as possible and with the minimum of disturbance to people living or working nearby;
- Operatives will be trained to employ appropriate techniques to keep site noise and vibration to a minimum, and will be effectively supervised to ensure that best working practice in respect of noise minimisation is followed.

## 5.0 Monitoring

### Survey Periods

5.1 Noise monitoring shall be undertaken during typical working hours when the site is operating normally and avoiding:

- lunch/break times;
- periods of plant maintenance or breakdown; and
- periods of peak road traffic on the local road network.

5.2 Monitoring shall be undertaken for a minimum of 1 hour total duration during the operational hours on Monday to Friday between 0700 – 1800 hrs.

### Monitoring Locations

5.3 Monitoring shall be undertaken in ‘free-field’ conditions, with the microphone placed at a height of between 1.2 - 1.5 metres above the ground and at least 3.5 metres away from other reflecting surfaces.

5.4 Monitoring shall be conducted at locations representing the following residential premises:

- Westhay Cottages and Farm
- Westhay Lodge
- Cuckoo Lodge
- Duddington Village

- 5.5 The exact location of the monitoring position will be decided prior to or during the survey visit depending on access and agreement with land owners/local residents.
- 5.6 Monitoring shall be undertaken either directly at the premises within an external amenity area, such as a private garden, or at an alternative location where the acoustic environment (including any contributions from the site) is considered to be similar.
- 5.7 Where possible, the selected monitoring locations should be accessible from public roads and footpaths and should also be available to the site operator as well as the regulators such as local authority officers.
- 5.8 In any event, full details of the selected monitoring locations shall be reported.

#### Measurement Parameters

- 5.9 The equivalent continuous A-weighted sound pressure level ( $L_{Aeq,1hour}$ ) shall either be measured directly (over a minimum one-hour period) or calculated from a number of shorter contiguous or disaggregated measurements (e.g.  $4 \times L_{Aeq,15min}$  or  $2 \times L_{Aeq,30min}$ ) via logarithmic averaging.
- 5.10  $L_{Amax}$  and  $L_{A90}$  noise levels shall also be recorded and reported.
- 5.11 Sound levels shall be measured using a 'fast' time weighting.

#### Sources of Interference

- 5.12 Precautions shall be taken to minimise the influence on the sound level readings from sources of interference such as temperature, wind, rain and electrical interference.

- 5.13 Monitoring shall be avoided during heavy precipitation and when wind speeds are greater than an average  $5 \text{ ms}^{-1}$  and when air temperatures are below  $3^{\circ}\text{C}$ .
- 5.14 All sound level meters shall be fitted with an effective windshield to minimise turbulence at the microphone.
- 5.15 Meteorological conditions prevailing during the monitoring shall be recorded and reported.

#### Observations

- 5.16 During the survey, detailed observations of the acoustic environment including the identification of any dominant sound sources will be recorded and reported.
- 5.17 Full details of the activities taking place at the ENRMF during the monitoring periods will also be recorded and reported.

#### Instrumentation

- 5.18 Instrumentation should preferably conform to Class/Type 1, but at least of Class/Type 2 as specified in either BS EN 61672-1:2013, BS 7580-1, BS 7580-2 or BS EN 60804.
- 5.19 Sound calibrators should preferably be Class/Type 1 and conform to BS EN 60942:2003, BS EN 60942 or BS 7189 (identical with IEC 942).
- 5.20 Sound level meters and field calibrators shall have had their conformity and calibration checked periodically in accordance with manufacturer recommendations or relevant standards.

- 5.21 With the equipment set up in the configuration used during measurement, field calibration checks shall be performed immediately before and after the survey period using a sound calibrator.
- 5.22 Any significant drift in the calibration value observed between the initial and final checks will be recorded and reported.

### Reporting

- 5.23 Noise monitoring shall be undertaken on 2 occasions per year at approximately 6 month intervals.
- 5.24 Noise monitoring reports will be prepared within 2 weeks of the completion of the monitoring and will be kept at the site offices for review by the Local Planning Authority when requested.
- 5.25 The results of the survey shall be evaluated against a site noise limit of 55 dB  $L_{Aeq,1h}$  free-field which is the limit specified in PPG for mineral/waste sites and has previously been adopted within the site's noise monitoring and management plan.
- 5.26 Where sound emissions from site activities are considered to have been the cause of a noise level above the specified limit, the Site Manager shall be notified and a review will be undertaken by the operator to determine the cause of the exceedance.
- 5.27 Following the review and, if practicable, the operator will implement suitable noise control measures in consultation with the Local Planning Authority.

## **6.0 Complaints**

- 6.1 It is the duty of all members of staff to receive and record complaints, which will be processed by the Site Manager.
- 6.2 The Operator will maintain a record of all complaints received. Any complaints will be responded to and recorded in accordance with the Complaints Procedure which forms part of the site Environmental Management System. Further information is provided within the DCO Environmental Commitments.
- 6.3 The complaints log will be made available to the Local Planning Authority for inspection upon request.
- 6.4 All complaints will be investigated to identify the likely source of the noise and/or vibration. If it is established that the operator could be the source then further investigation will be undertaken to determine the scale of impact.
- 6.5 Should clear impacts from site operations be identified then, if practicable, the operator will implement suitable control measures in consultation with the Local Planning Authority.
- 6.6 During any investigation and subsequent remedial action, the complainant will be kept updated of progress.

## **7.0 Management, Training and Responsibility**

- 7.1 The Site Manager will have responsibility for ensuring that nuisances and hazards arising from the operations due to noise and vibration are minimised, and that the measures outlined in this NVMP are implemented, documented and subject to ongoing evaluation and review through the procedure review process which forms part of the site Environmental Management System.
- 7.2 The Operator conducts its operations according to management systems that are designed to ensure that all staff are competent to carry out the tasks that have been designated their responsibility.
- 7.3 The company identifies training requirements of its employees and provides suitable resources to ensure they have the required knowledge, skills and expertise to carry out their duties. This includes their roles and responsibilities in complying the Operator's management systems and all relevant legislation. This is achieved through induction, training for new employees, awareness training for all and specific training as required as set out in the Environmental Management System.
- 7.4 Contractors and all persons performing tasks on behalf of Augean will also be made aware of the policy and relevant management system requirements and will be competent in the roles undertaken.
- 7.5 Operatives will be trained to employ appropriate techniques to keep site noise and vibration to a minimum and will be effectively supervised by the Site Manager to implement best working practice. All operational staff and contractors will be responsible for reporting any problems relating to noise and vibration directly to the Site Manager.

7.6 All staff at the site will be made fully aware of the need to be constantly vigilant about the control and management procedures in place. To minimise the risk of noise and vibration emissions, emphasis will be given to:

- Awareness of their responsibilities for avoiding noise nuisance;
- The timely reporting of noise issues directly to the Site Manager; and
- Actions to minimise noise emissions during abnormal operating scenarios that could give rise to noise issues.